

Most - Often - Needed

1964

Volume R-24

RADIO
DIAGRAMS
and Servicing Information



Compiled by
M. N. BEITMAN

SUPREME PUBLICATIONS

Supreme Publications for Faster Radio-Television Repairs

COVERS ALL POPULAR SETS

Here is your service data for faster, easier TV repairs. Lowest priced. Best by comparison. *Supreme TV* manuals have all needed service material on every popular TV set. Helpful, practical, factory-prepared data that will really make TV servicing easy for you. Benefit and save with these amazing values in service manuals. Only \$3 per large volume. Used by 184,000 wise servicemen for faster repairs. Join them; begin to make TV repairs easily.

Most - Often - Needed

1963

Television

Service Information



The repair of any TV set is simple with **Supreme Television** service manuals. Every set is covered in a practical manner to simplify trouble-shooting and repair. With this help find toughest faults in a jiffy. Most \$3 TV volumes cover a whole year.

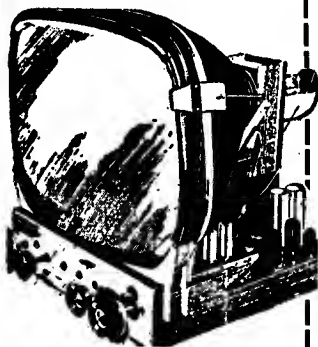

RADIO Manuals

Your best source for all needed RADIO diagrams and service data. Covers everything from most recent 1963 radios to pre-war old-timers; home radios, stereo, combinations, transistor portables, FM. Every manual has large schematics, all needed alignment facts, printed boards, voltages, trimmers, dial stringing, and hints. Volumes are big, 8½x11 inches, about 190 pages. See coupon at right for list of **SUPREME** popular radio service manuals ▶

—NO-RISK ORDER COUPON—

TELEVISION SERVICE MANUALS

Supreme TV manuals are best for faster, easier TV repairs. Lowest priced. Factory data on practically all sets. Complete circuits, all needed alignment facts, wiring board views, waveforms, voltages, production changes, and double-page schematics. Only \$3 per large annual manual. Check volumes wanted.

- New 1963 Television Servicing Manual, only \$3.
- Additional 1962 TV, \$3. Early 1962 TV, \$3.
- 1961 TV Manual, \$3. 1960 TV Manual, \$3.
- Additional 1959 TV, \$3. Early 1969 TV, \$3.
- 1958 TV Manual, \$3. Additional 1957 TV, \$3.
- Early 1957 Television, \$3. 1956 TV Manual, \$3.
- Additional 1955 TV, \$3. Early 1955 TV, \$3.
- 1954 TV, \$3. 1953 TV, \$3. 1952 TV, \$3.
- 1951 TV, \$3. Master Index to all Manuals, 25¢

RADIO DIAGRAM MANUALS

Here are low-priced radio manuals that simplify repairing. Cover everything from most recent 1963 radios to pre-war old-timers; home radios, stereo, combinations, transistor portables, FM, and auto sets. Large schematics, all needed alignment facts, printed boards, voltages, dial stringing, hints. Volumes are big, 8½ x 11", about 190 pages, each.

\$2⁵⁰

- 1963, 1962, 1961, 1960, 1959, 1958,
- 1957, 1956, 1955, 1954, 1953, 1952,
- 1951, 1950, 1949, 1948, 1947, 1946,
- 1942, 1941, 1940, 1926-38, EACH, \$2.50

SUPREME PUBLICATIONS

1760 Balsam Road, Highland Park, ILL.

Rush today **TV** and **Radio** manuals checked in no-risk order form of this ad. Send postpaid, I am enclosing full price. You guarantee my complete satisfaction or my money back.

Name: _____
Address: _____
City: _____ State: _____

ADMIRAL

MODEL Y4659 - Y4677
CHASSIS 4S3A

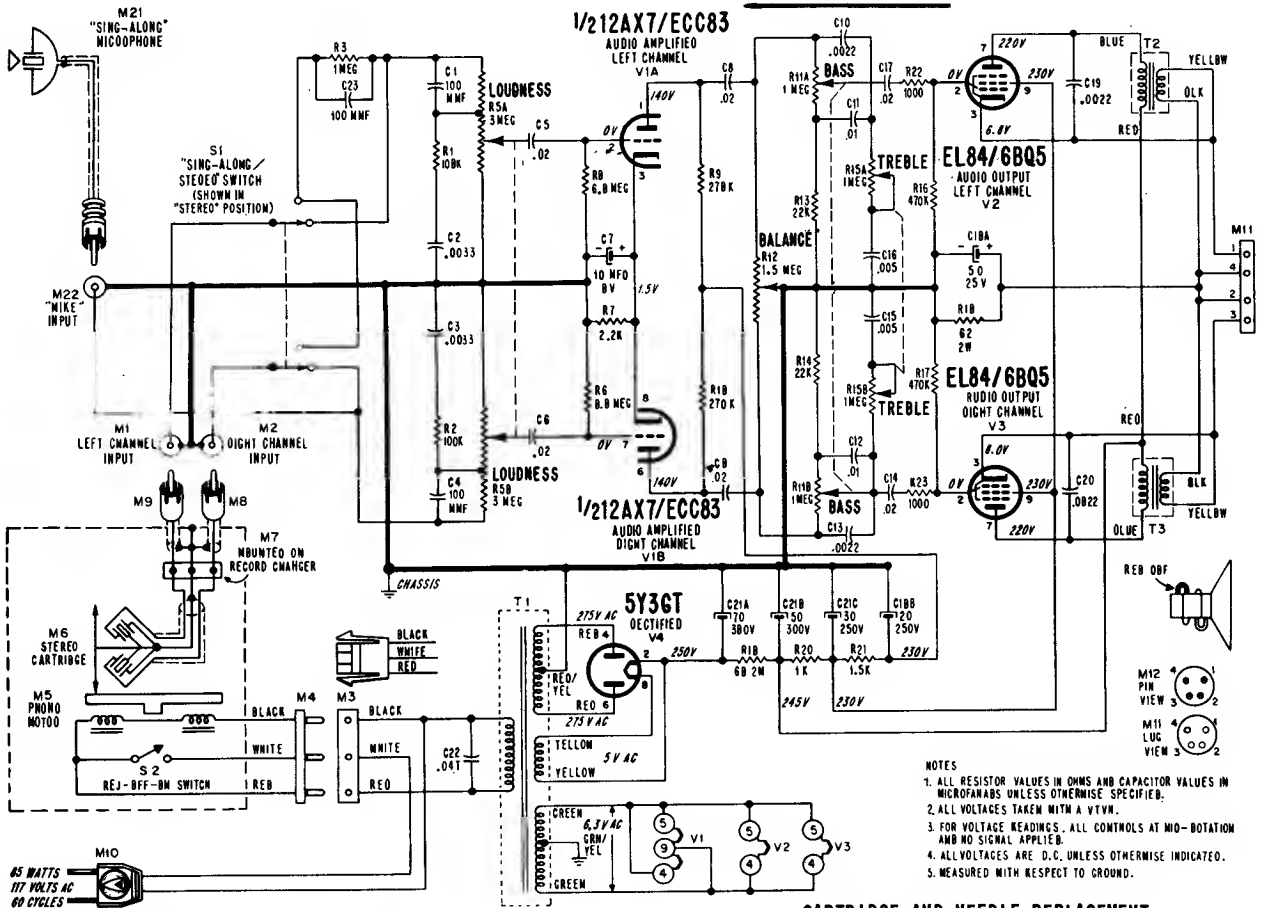

- NOTES
1. ALL RESISTOR VALUES IN OHMS AND CAPACITOR VALUES IN MICROFARADS UNLESS OTHERWISE SPECIFIED.
 2. ALL VOLTAGES TAKEN WITH A VTVM.
 3. FOR VOLTAGE READINGS, ALL CONTROLS AT MID-POTENTIAL AND NO SIGNAL APPLIED.
 4. ALL VOLTAGES ARE D.C. UNLESS OTHERWISE INDICATED.
 5. MEASURED WITH RESPECT TO GROUND.

CARTRIDGE AND NEEDLE REPLACEMENT

Turn needle selector handle so that desired number (78 or LPS) faces up; corresponding needle will point down. With thumbnail, pull flange at rear of worn needle straight away from cartridge. Line up parallel flanges of new needle with opening in cartridge case and press in place with fingertip.

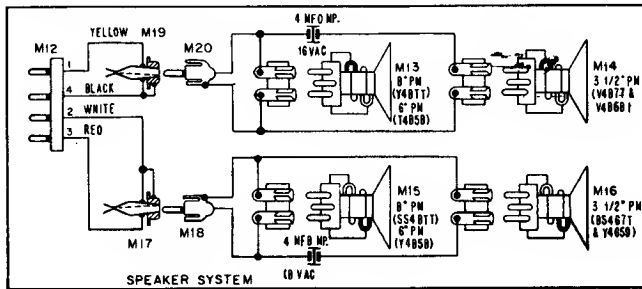

CHASSIS REMOVAL

Disconnect the line cord. Remove four screws holding chassis grille in place. Pull all control knobs off. Remove the nuts under the knobs of the treble and loudness controls while supporting the chassis. Chassis may now be lowered and pulled out for easy servicing.

IMPORTANT: For regular phonograph operation when "sing along" microphone is not being used, unplug microphone from socket and move switch back to "Stereo" position. If microphone is not disconnected with switch in "Stereo" position, the two sound channels will become out of balance, affecting satisfactory sound reproduction. Connect microphone only when using "sing along" operation.

ADMIRAL CHASSIS 1F1B MODEL Y4918

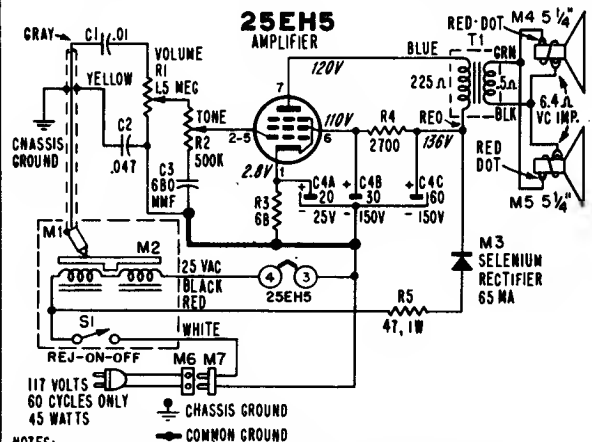

- NOTES:
- ALL RESISTOR VALUES IN OHMS AND CAPACITOR VALUES ARE IN MICROFARADS UNLESS OTHERWISE SHOWN. ALL VOLTAGES TAKEN WITH VACUUM TUBE VOLTMETER.

ADMIRAL

CHASSIS: 4X3, 4X3A
 MODELS: Y3303, Y3308, Y3309, Y3337, Y3443

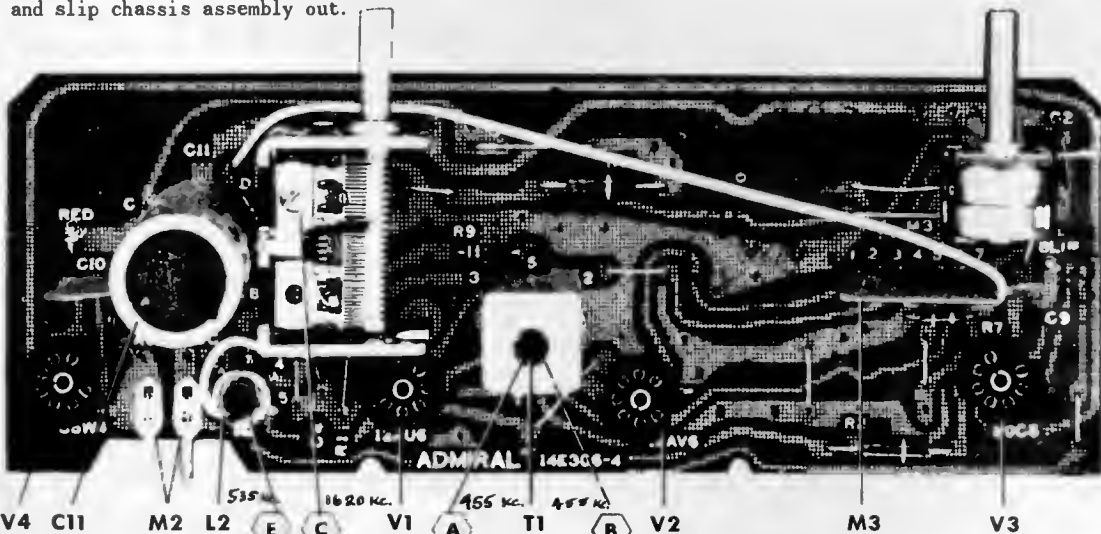
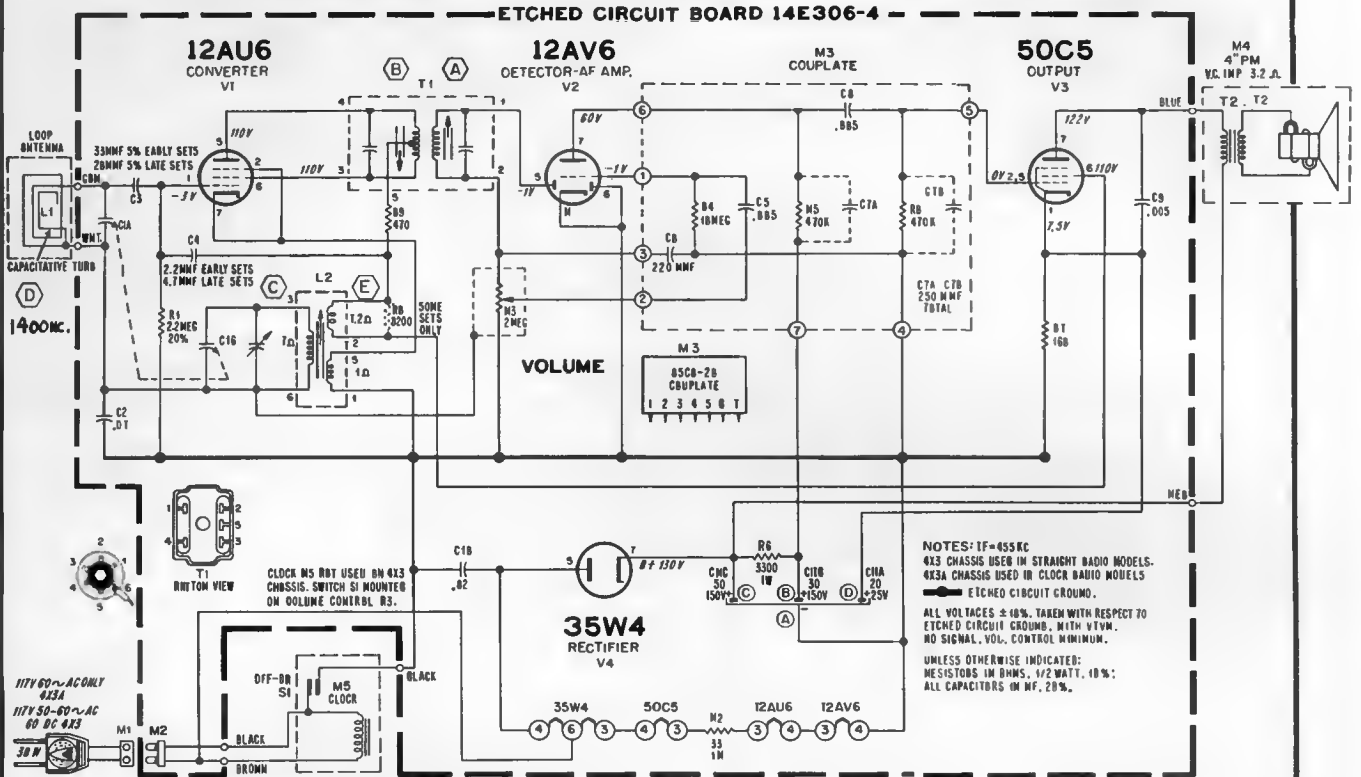

TOP VIEW OF CHASSIS (4X3) SHOWING COMPONENTS AND ALIGNMENT POINTS

ADMIRAL

Chassis 5D6A, 5D6B, 5D6C,
Models Y3321, Y3323, Y3346, Y3353,
Y3354, Y3359, Y3363, Y3364, Y3368,
Y3376, Y3377, Y3379, Y3381, Y3383.

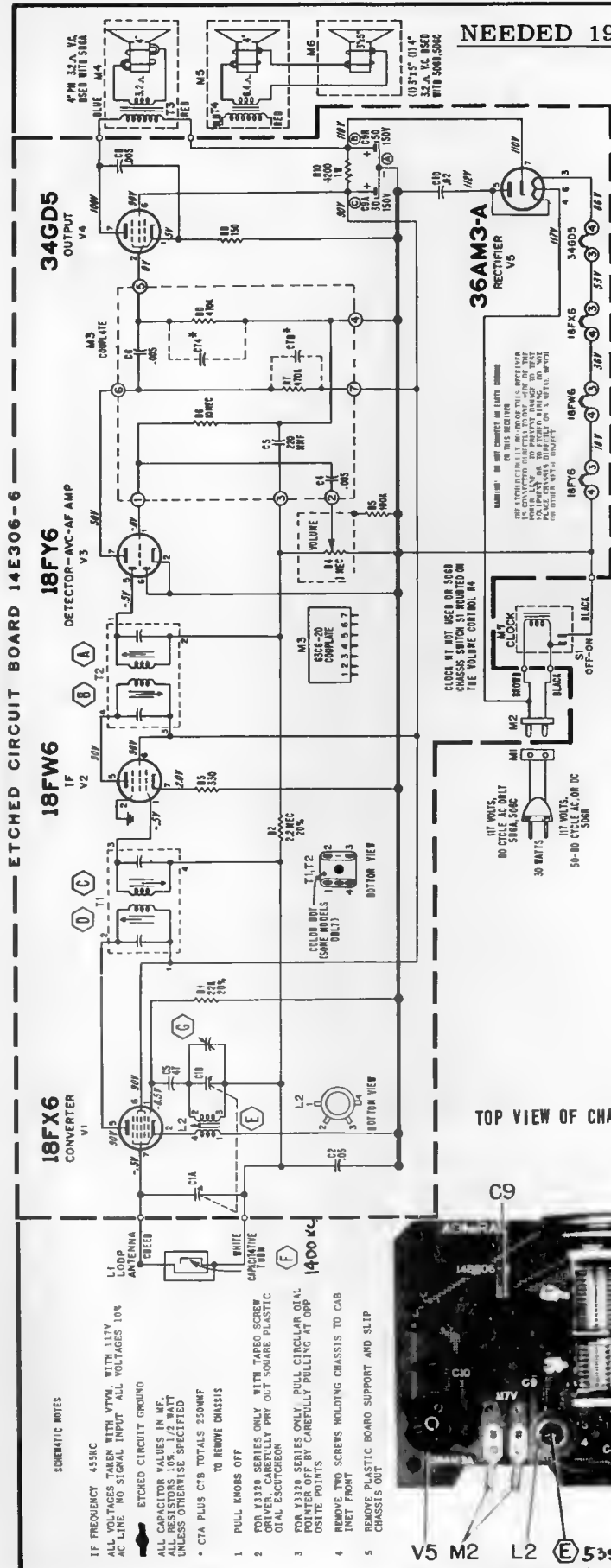

DIAL STRINGING DIAGRAM - 5D6B CHASSIS

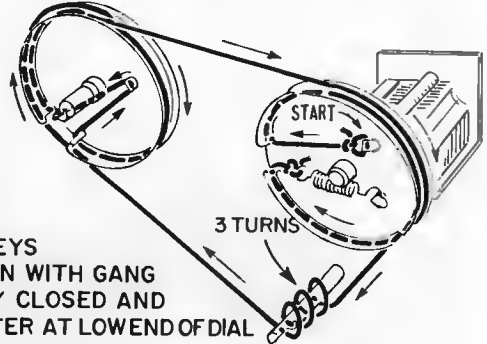

DIAL STRINGING DIAGRAM - 5D6C CHASSIS

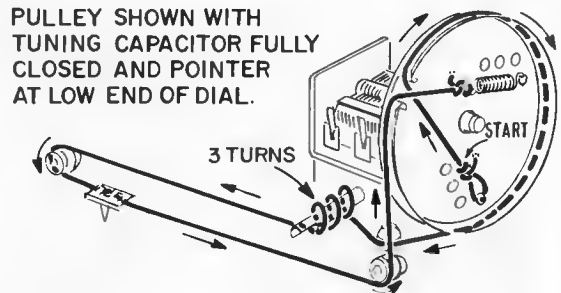

TOP VIEW OF CHASSIS (5D6B) SHOWING COMPONENTS AND ALIGNMENT POINTS

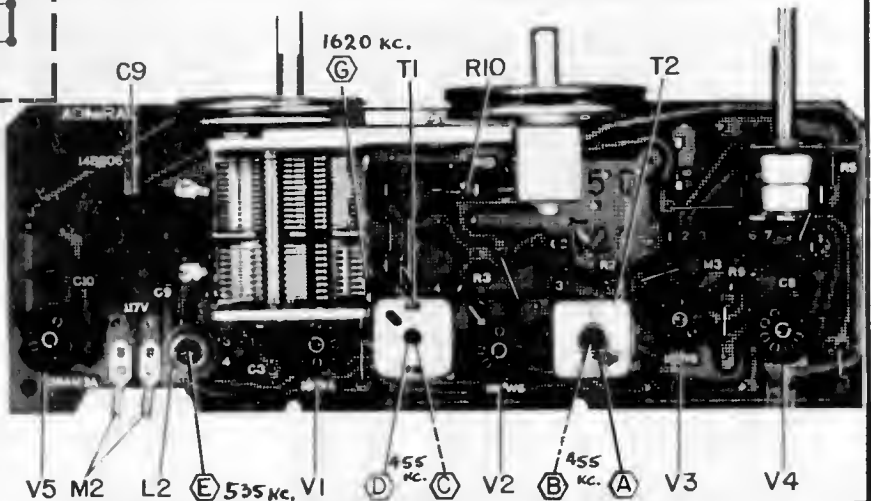

VOLUME R-24, MOST-OFTEN-NEEDED 1964 RADIO SERVICING INFORMATION

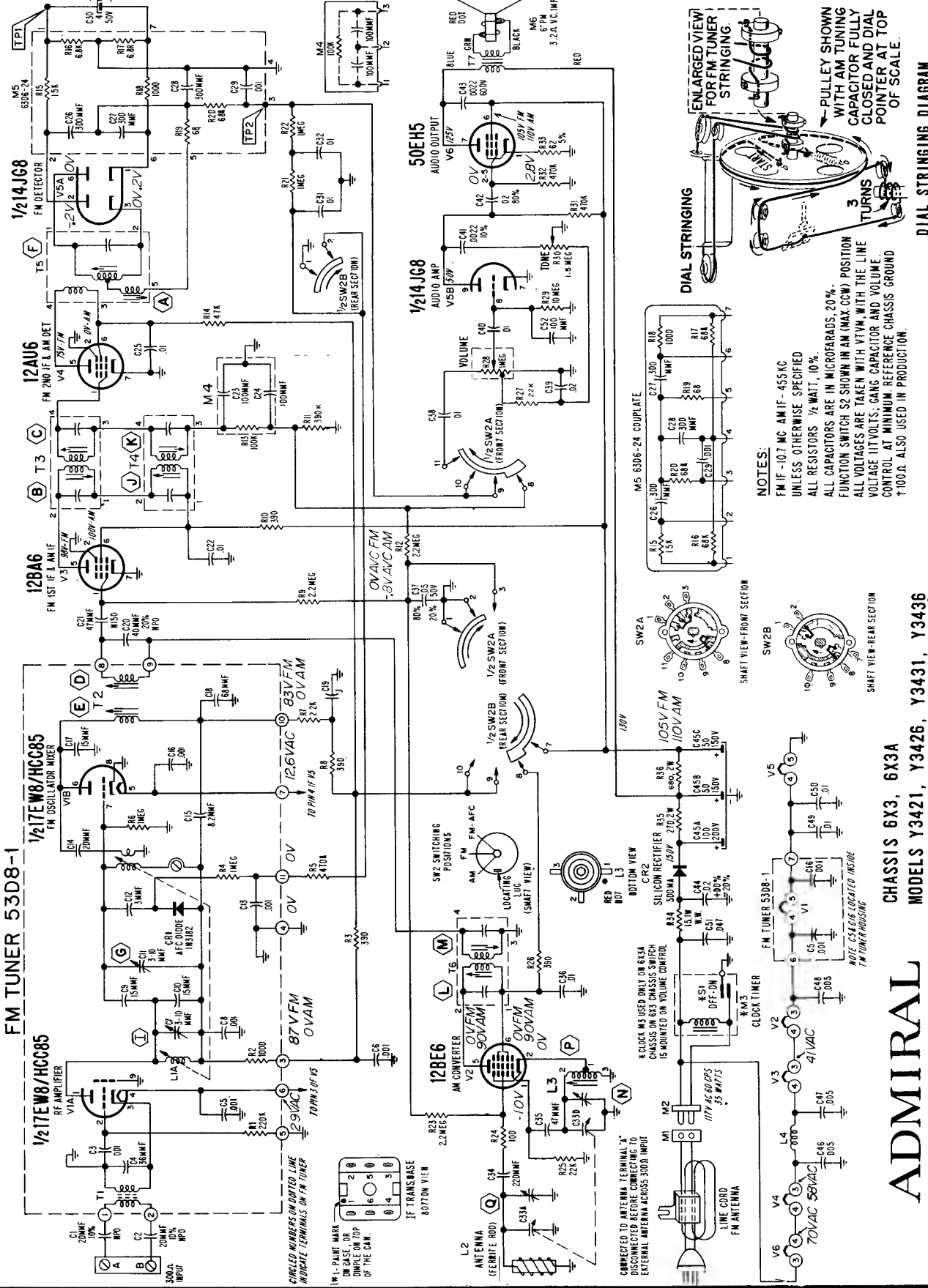

NOTES:
 FM IF -107 MC AM IF -455 KC
 UNLESS OTHERWISE SPECIFIED
 ALL RESISTORS 1/2 WATT, 10%
 ALL CAPACITORS ARE IN MICROFARADS 20%
 FUNCTION SWITCH SHOWN IN AM (MAX. CCW) POSITION
 ALL VOLTAGES ARE TAKEN WITH VTVM, WITH THE LINE
 VOLTAGE 117VOLTS. GANG CAPACITOR AND VOLUME
 CONTROL AT MINIMUM. REFERENCE CHASSIS GROUND
 100Ω. ALSO USED IN PRODUCTION.

CHASSIS 6X3, 6X3A
 MODELS Y3421, Y3426, Y3431, Y3436

ADMIRAL

ADMIRAL Chassis 7L2, Model Y2347

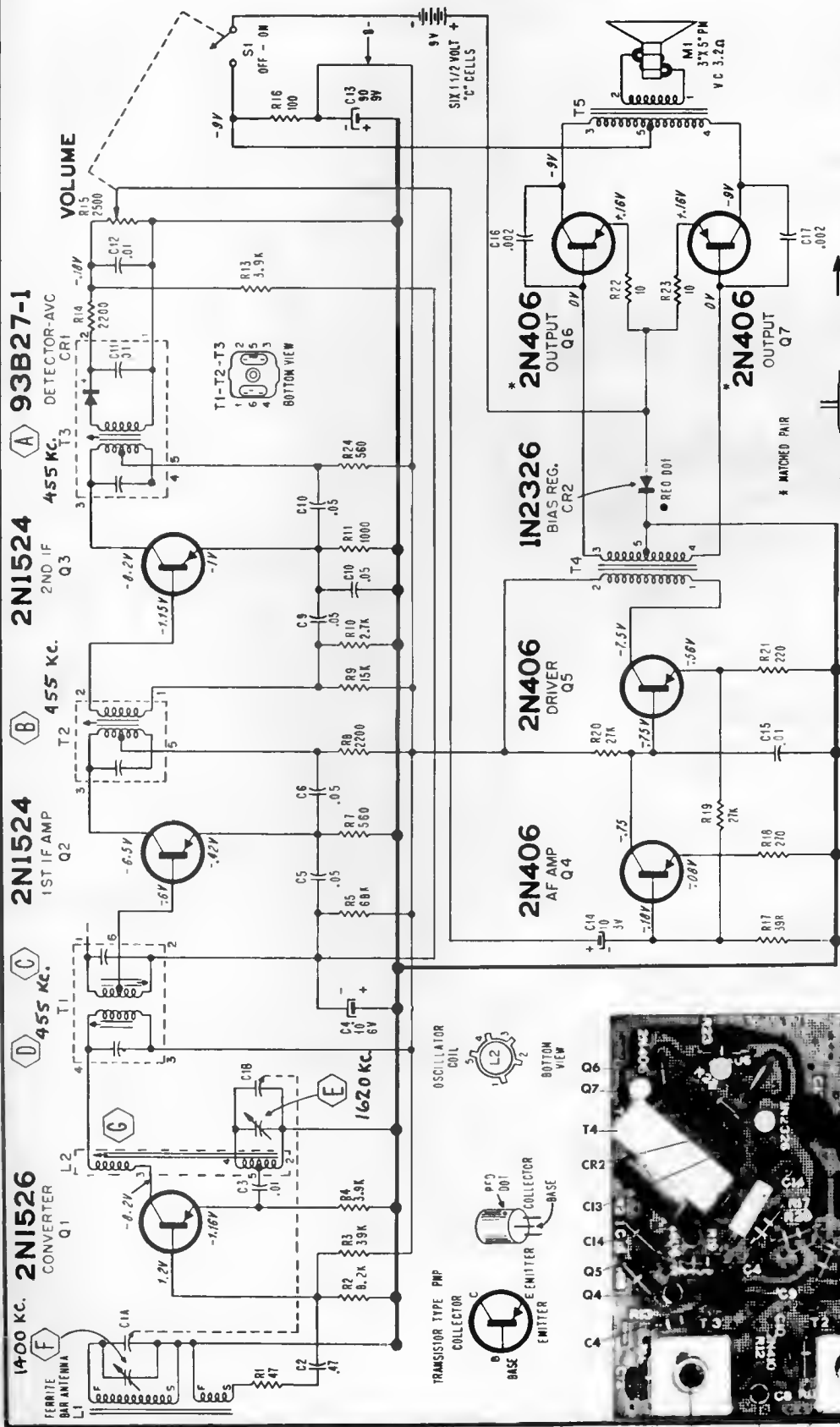

NOTES: IF=455 KC

- COMMON ETCHED CIRCUIT GROUND UNLESS OTHERWISE SPECIFIED;
- CAPACITOR VALUES IN MICROFARADS
- RESISTOR VALUES IN OHMS. 1/2 WATT, 10%.
- VOLTAGE READINGS TAKEN WITH V.T.V.M. USING FRESH BATTERIES, NO SIGNAL, VOLUME CONTROL MINIMUM
- TOTAL CURRENT DRAIN (NO SIGNAL) = 7-10 MA.
- BT IS NOT GROUNDED.

DIAL POINTER AT 55 ON SCALE

PULLEY SHOWN WITH GANG CAPACITOR FULLY CLOSED

DIAL STRING DIAGRAM

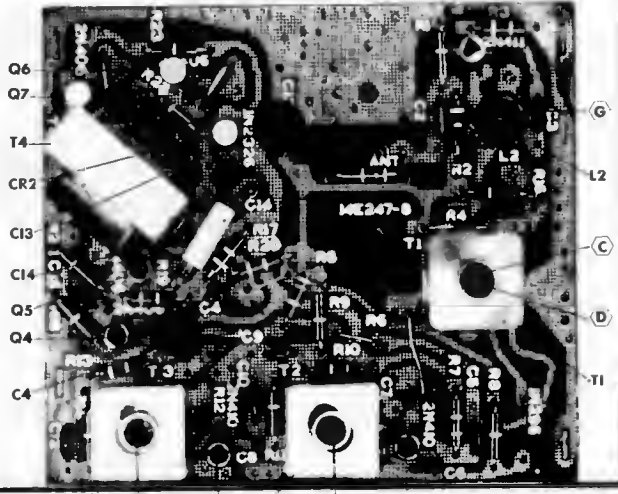

VOLUME R-24, MOST-OFTEN-NEEDED 1964 RADIO SERVICING INFORMATION

ADMIRAL Chassis 9P1 and similar Chassis 8P1, list of models below, continued

Models Y4851, Y4852, Y4871, Y4872, Y4885, Y4941A, and TV sets SM3811, SM3812, SM3815, SM3831, SR3501, SR3502, SM3503.

1/2 17EW8/HCC85

1/2 17EW8/HCC85

TOP VIEW OF CHASSIS
ALIGNMENT POINTS AND COMPONENTS

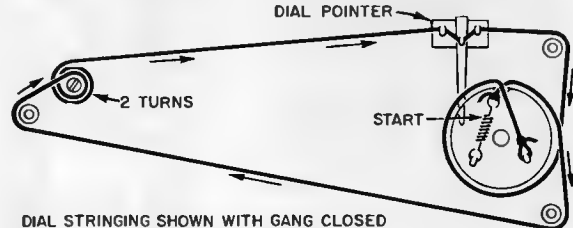
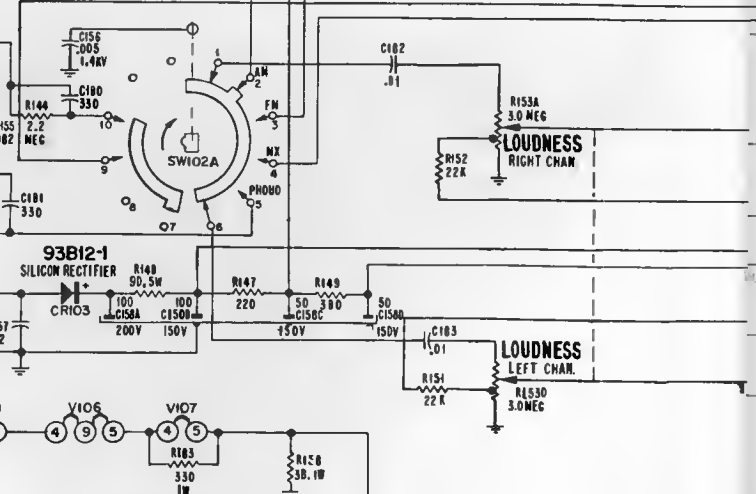
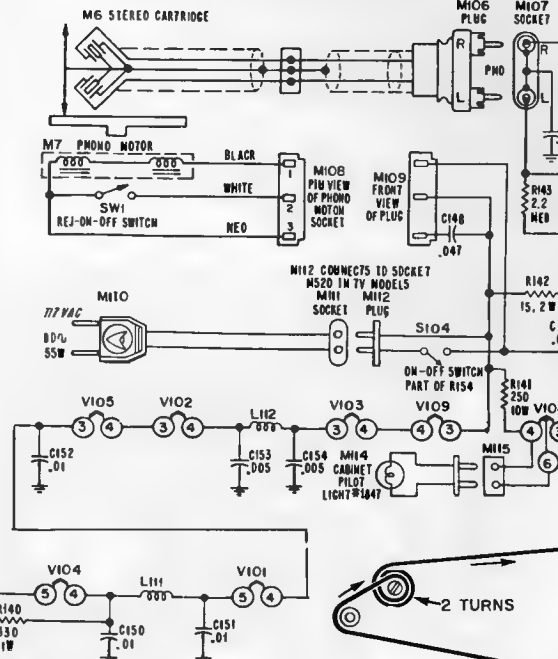
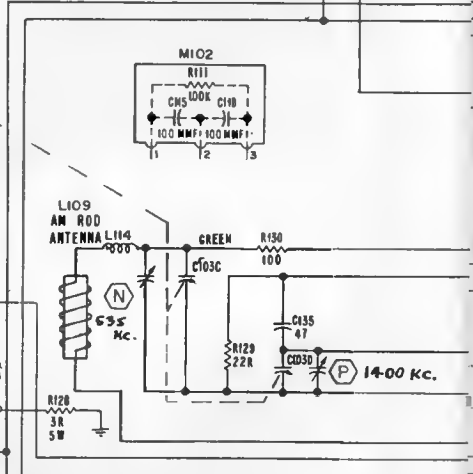
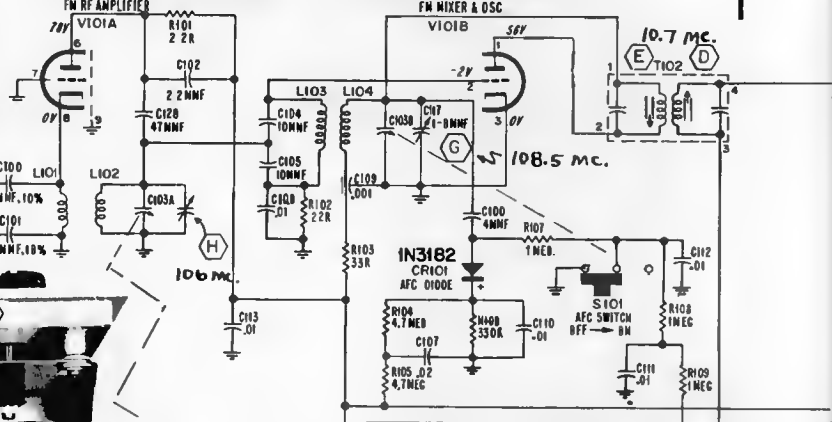
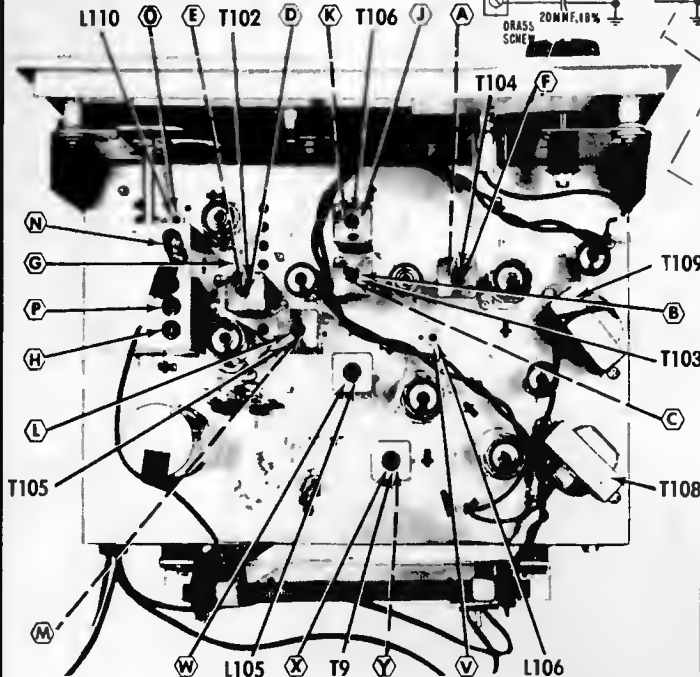

1. EM IE - 10.7 MC
2. AM IE - 455 KC.
3. UNLESS OTHERWISE SPECIFIED ALL RESISTORS 1/2 WATT, 10%. ALL CAPACITORS IN MICROFARADS.
4. FUNCTION SWITCH SW102 SHOWN IN AM POSITION (ARROW IS FULLY COUNTER CLOCKWISE) TO SIMPLY THE SCHEMATIC. SW102 SWITCH SECTIONS ARE SHOWN ON SCHEMATIC. MECHANICAL VIEWS IDENTIFY CONNECTION P'TS.
5. VOLTAGES ARE MEASURED WITH 117V AC INPUT
6. ⓪ DENOTES CHASSIS GROUND.

DIAL STRINGING SHOWN WITH GANG CLOSED AND DIAL POINTER AT LOW END OF DIAL SCALE.

VOLUME R-24, MOST-OFTEN-NEEDED 1964 RADIO SERVICING INFORMATION

ADMIRAL Chassis 9P1 (and 8P1) used in models listed on preceding page

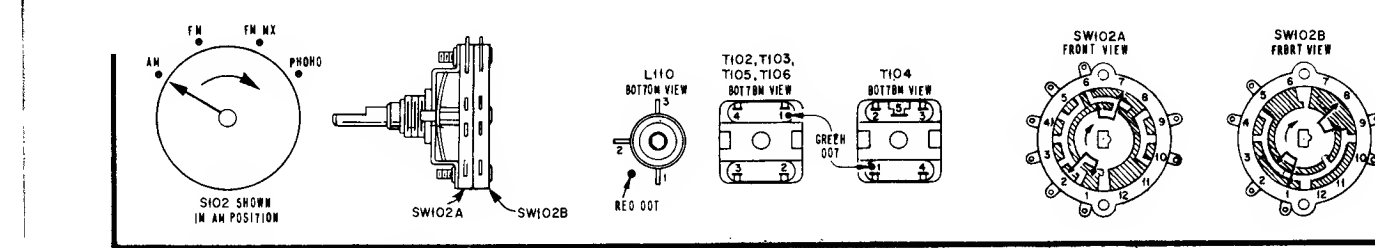
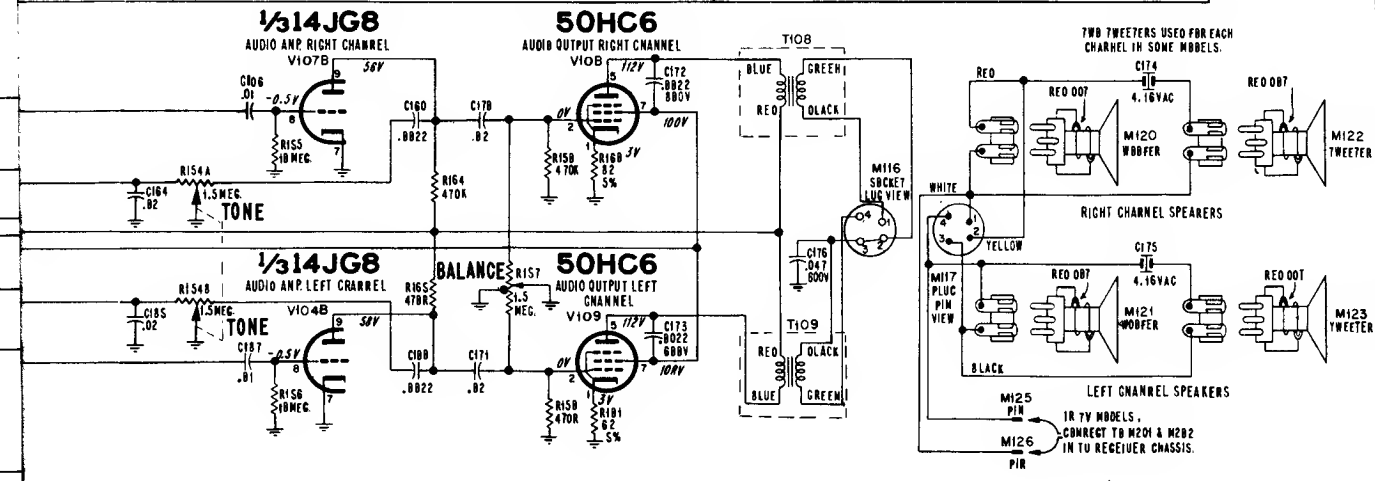
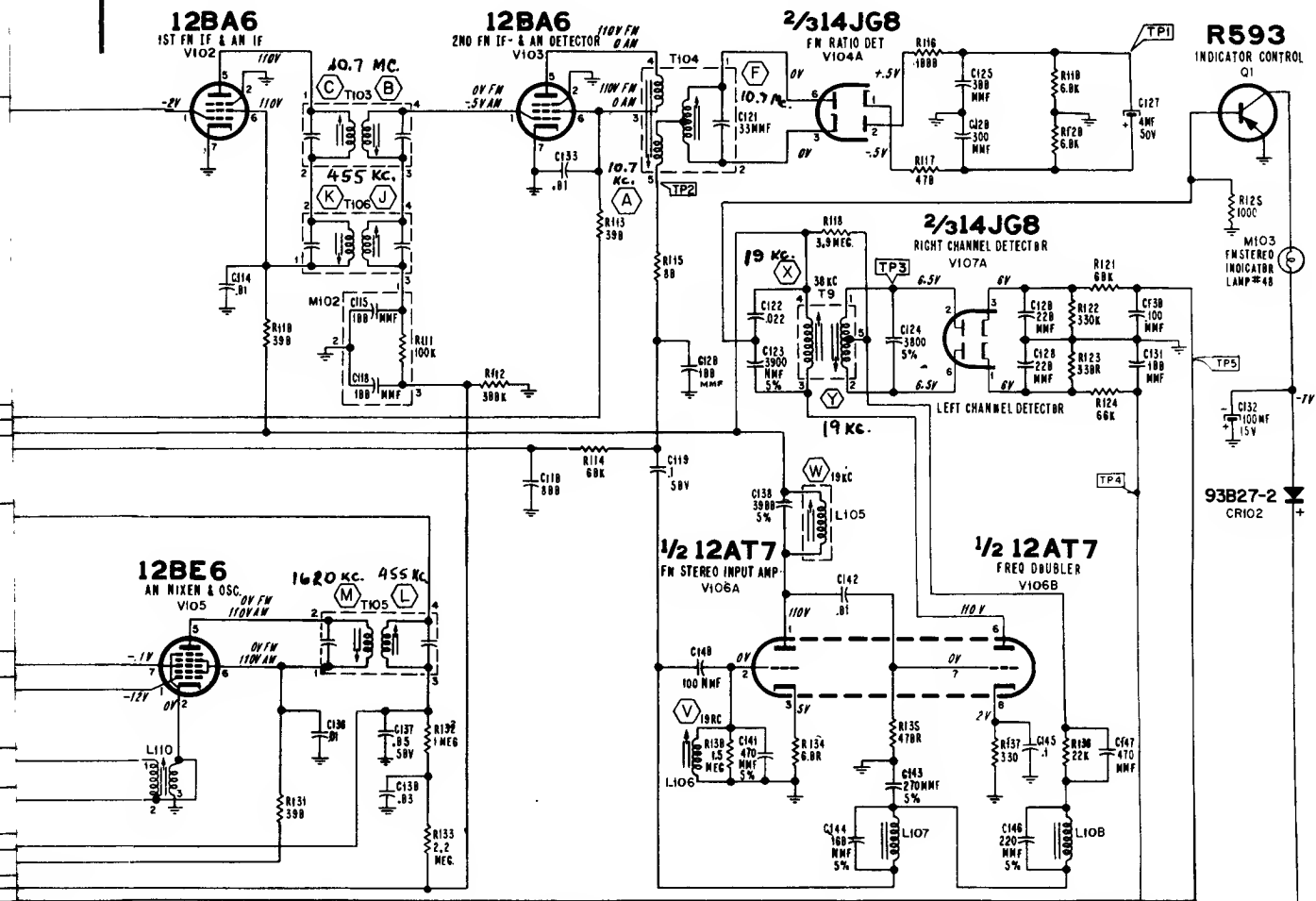

ADMIRAL

CHASSIS: 8G2
MODEL: Y2351

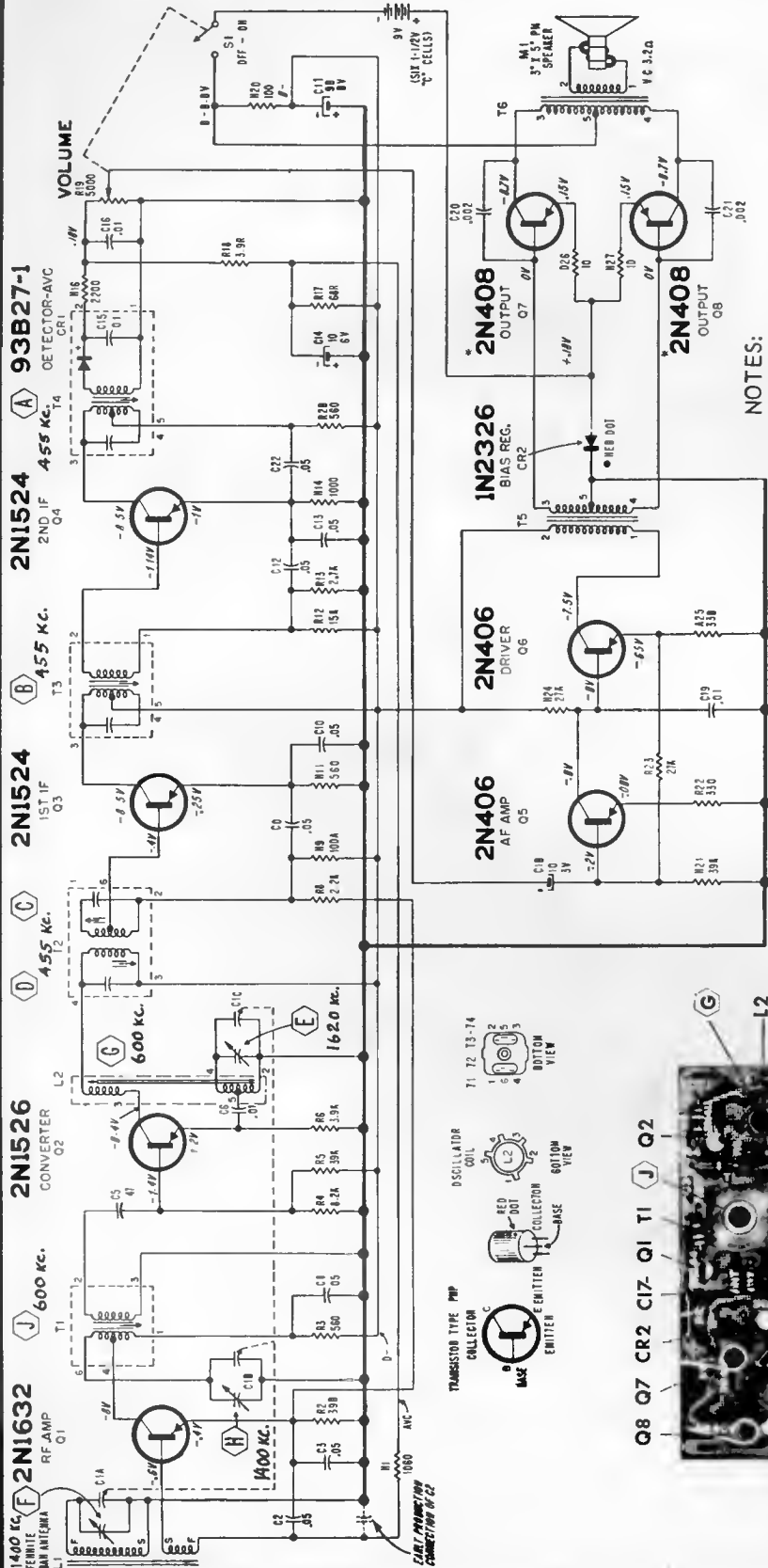

NOTES:

- COMMON ETCHED CIRCUIT GROUND UNLESS OTHERWISE SPECIFIED;
- CAPACITOR VALUES IN MICROFARADS
- RESISTOR VALUES IN OHMS, 1/2 WATT, 10% VOLTAGE AND CURRENT READINGS TAKEN WITH FRESH BATTERIES, NO SIGNAL, VOLUME CONTROL MINIMUM

TOTAL CURRENT DRAIN (NO SIGNAL) = 8 - 11 MA
B+ NOT GROUNDING IF = 455 KC *MATCHED PAIR

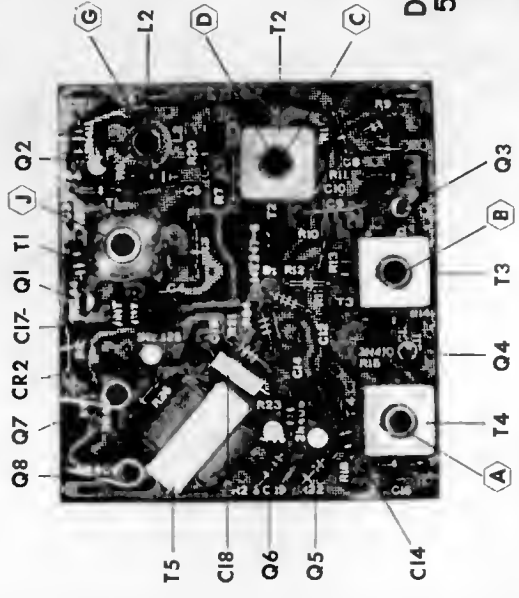
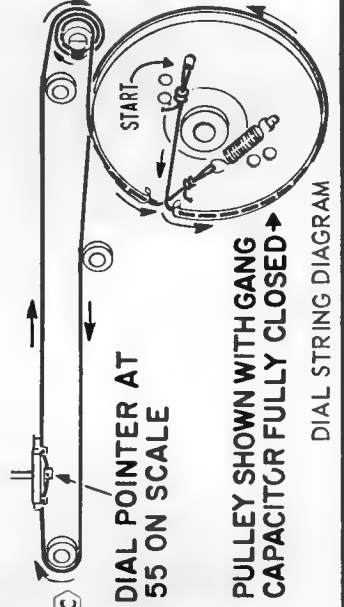
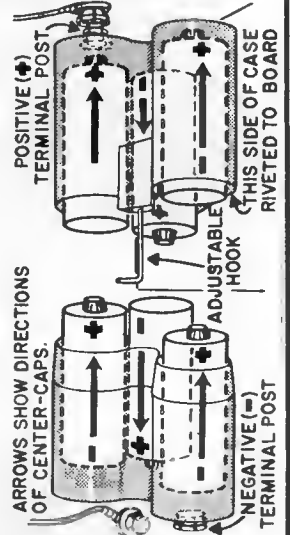

TOP VIEW OF ETCHED CIRCUIT BOARD
This view is of an early production set and may appear slightly altered in other sets.

VOLUME R-24, MOST-OFTEN-NEEDED 1964 RADIO SERVICING INFORMATION



Models 53R05, 53R07, Code 1.74401, Models 53R17, 53R19, Code 1.75401, Models 53R27, 53R28, Code 1.76001, and electrically similar Models 13R35, 13R37, Code 1.74501, which use dual speakers and are less clock.

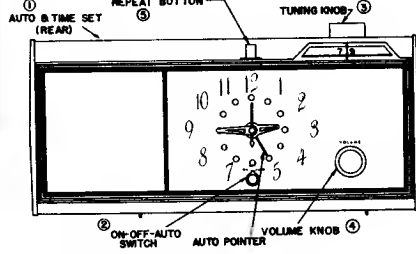
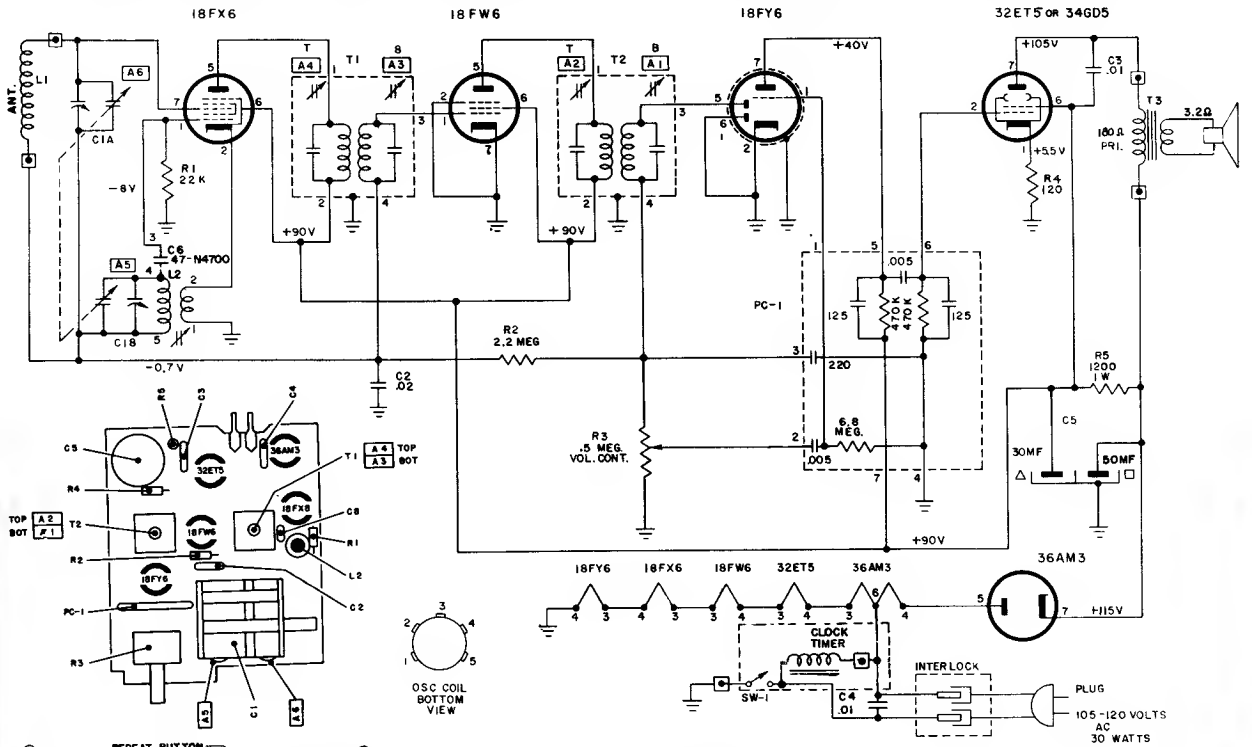

ON-OFF-AUTO SWITCH
The small knob (2) below clock face operates a three position switch. When the knob is turned to the center position the radio will be turned off. With this knob in the left position, the radio receiver is turned on. After allowing about 30 seconds for "warm-up", the radio receiver will be in operation if the TUNING (3) and the VOLUME (4) CONTROLS have been properly adjusted. When this (2) knob is turned to the right position, the radio will be turned on automatically when the hands of the clock indicate the time for which the AUTO POINTER is set.

±.8-
□ EXTERNAL CONNECTIONS TO PRINTED BOARD.
VOLTAGES MEASURED WITH A V.T.V.M.
RESISTANCE VALUES ARE IN OHMS K=1,000, MEG=1,000,000.
CAPACITANCE VALUES LESS THAN (1) ARE IN MICROFARADS (μF), AND VALUES OF (1) OR GREATER ARE IN MICROMICROFARADS (μμF), UNLESS OTHERWISE INDICATED.

ALIGNMENT PROCEDURE

PRELIMINARY:

- Output meter connection Across speaker voice coil
- Output meter reading to indicate 500 milliwatts (standard output) 1.0 volts
- Connection of generator ground lead Floating ground
- Generator modulation 30% 400 cycles

Position of Variable	Frequency of Generator	Dummy Antenna	Generator Output Connection	Trimmers Adjusted in Order Shown for Maximum Output	Function of Trimmer
Open	455 Kc	.05 μ fd	Pin 7 18FX6	A1, A2, A3, A4	I.F. Oscillator Antenna
Open	1670 Kc		* Test Loop	A5	
1400	1400 Kc		* Test Loop	A6	
1000	1000 Kc		* Test Loop	Fan C1A Plates	
600	600 Kc		* Test Loop	Fan C1A Plates	

* Standard Hazeltine Test Loop Model 1150 or 3 turns of wire about 6" in diameter placed about one foot from the set loop.
The alignment procedure should be repeated in the original order for greatest accuracy. Always keep the output from the signal generator at its lowest possible value to make the AVC action of the receiver ineffective.

Arvin

Model 63R58

Code 1. 75101

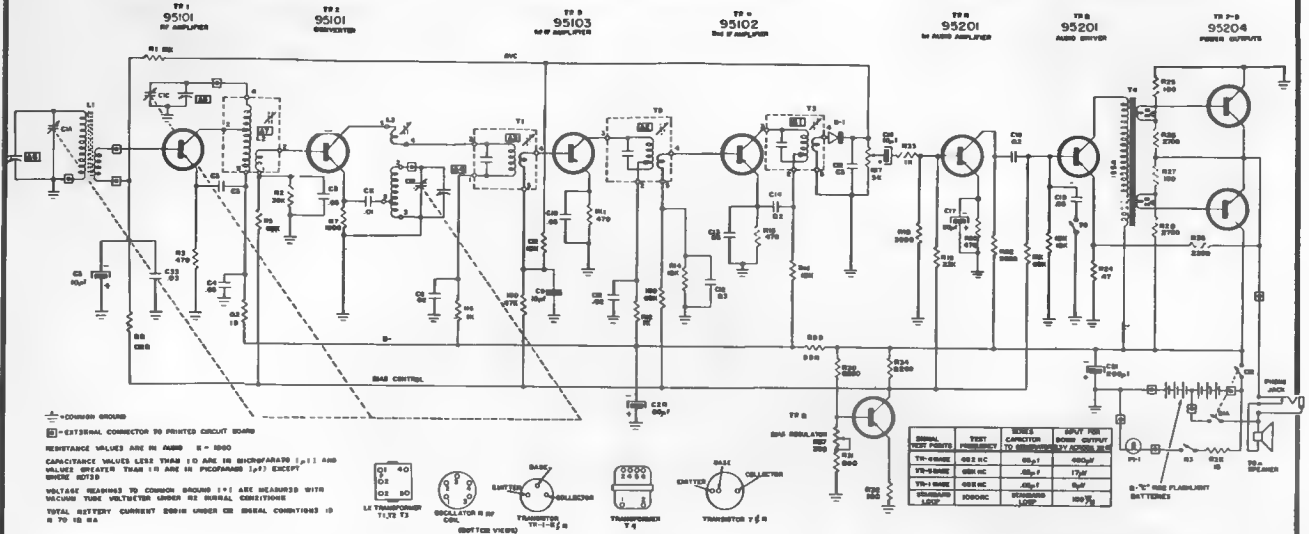

Alignment

Position of Variable	Generator Frequency	Trimmers Adj. in order shown for Max. Output	Function of Trimmer
Open	455 Kc	A1 (Top of T3) A2 (Top of T2) A3 (Top of T1)	L. F. I. F. I. F.
Open	1640 Kc	A4	Oscillator
1400 Kc	1400 Kc	A5 A6	Converter Antenna
600 Kc	600 Kc	Check Point A7	Converter

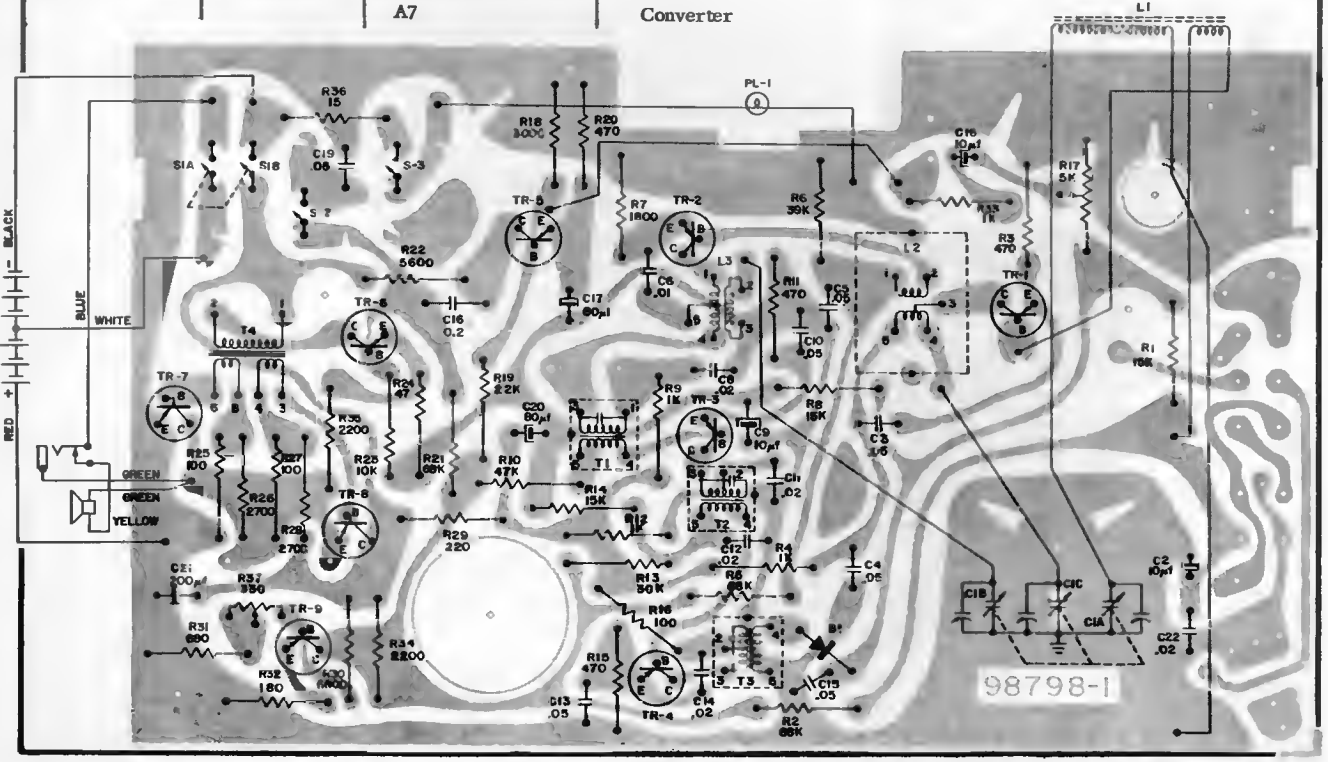
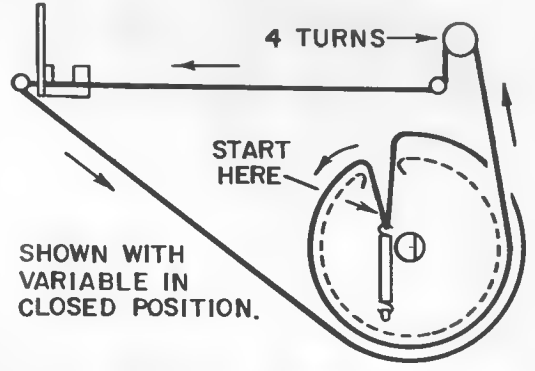

ARVIN Model 63R38, Code 1.75001

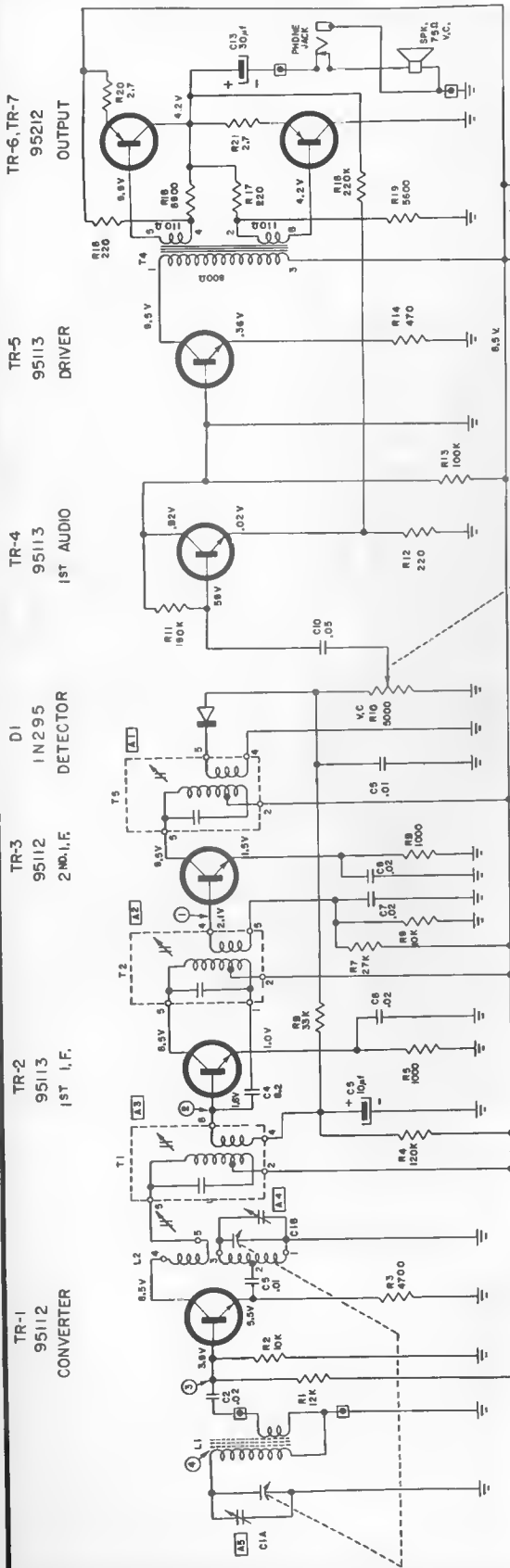

SIGNAL TEST POINTS	TEST FREQUENCY	SERIES CAPACITOR TO GENERATOR	INPUT FOR 5 W. OUTPUT (L.V. ACROSS T5)
①	455 KC	.05 μ F	500 μ V
②	455 KC	.05 μ F	12 μ V
③	455 KC	.05 μ F	2 μ V
④	1000 KC	STANDARD LOOP	200 μ V/M



I. F. 455 KC.

CAPACITANCE VALUES LESS THAN 100 ARE IN PICO-FARADS (pF) EXCEPT WHERE NOTED.
 VOLTAGE READINGS TO COMMON GROUND ARE MEASURED WITH VACUUM TUBE VOLTMETER UNDER NO SIGNAL CONDITIONS WITH TUNING CONTROL AT MAXIMUM COUNTERCLOCKWISE ROTATION.
 RESISTANCE VALUES ARE IN OHMS, K=1000.
 $\frac{1}{2}$ = COMMON GROUND SYMBOL.
 \square = EXTERNAL CONNECTION TO PRINTED CIRCUIT
 TOTAL BATTERY CURRENT DRAIN UNDER NO SIGNAL CONDITIONS, 8 TO 14 MA.

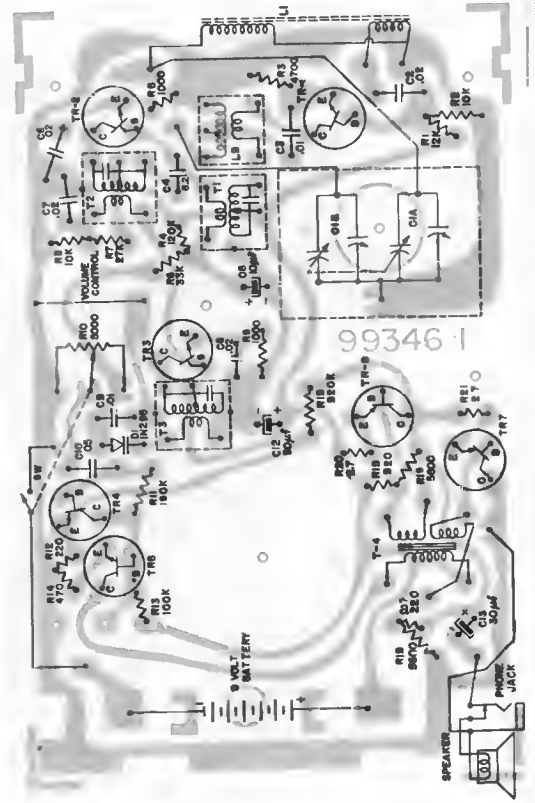
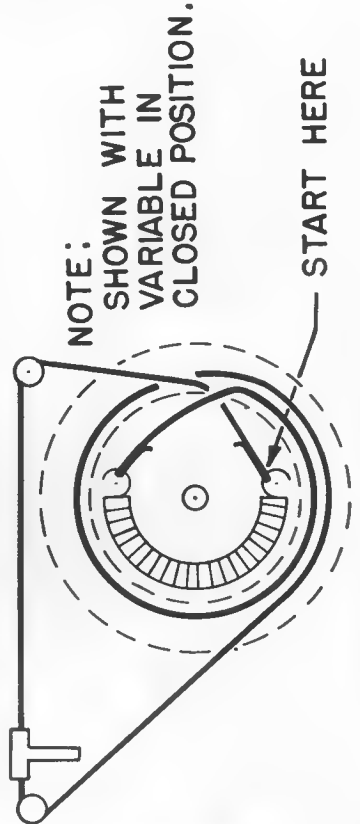

VOLUME R-24, MOST-OFTEN-NEEDED 1964 RADIO SERVICING INFORMATION

ARVIN Models 83P43, 83P53, 83P55, Code 1.77001, and Model 83P15, Code 1.67201, is very similar except for tone control and motor type.

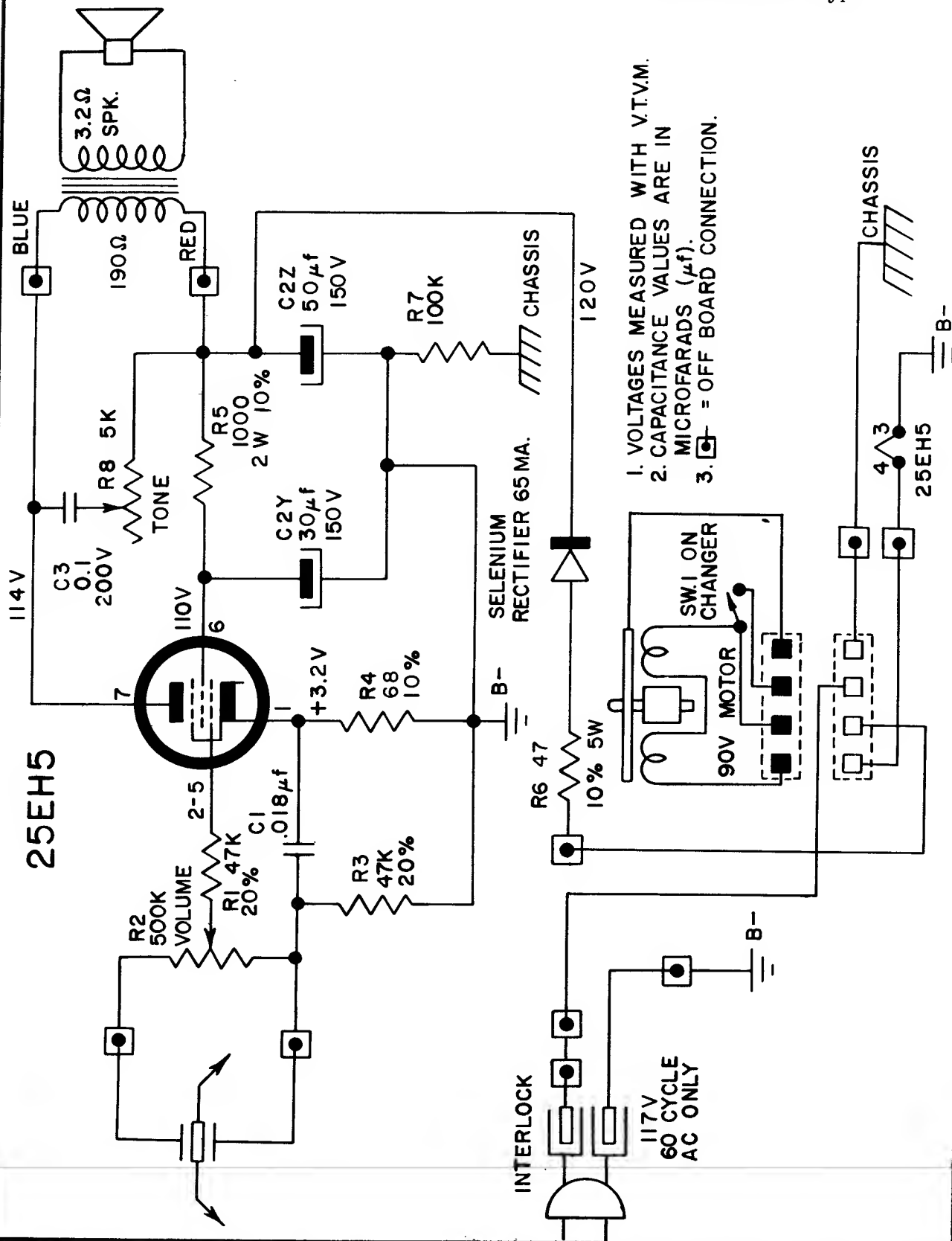

1. VOLTAGES MEASURED WITH V.T.V.M.
2. CAPACITANCE VALUES ARE IN MICROFARADS (μ f).
3.  = OFF BOARD CONNECTION.

VOLUME R-24, MOST-OFTEN-NEEDED 1964 RADIO SERVICING INFORMATION

ARVIN Models 33R28, 33R29, Code 1.74301, and Model 43R43, Code 1.78001, which is very similar but includes a tone control and clock timer.

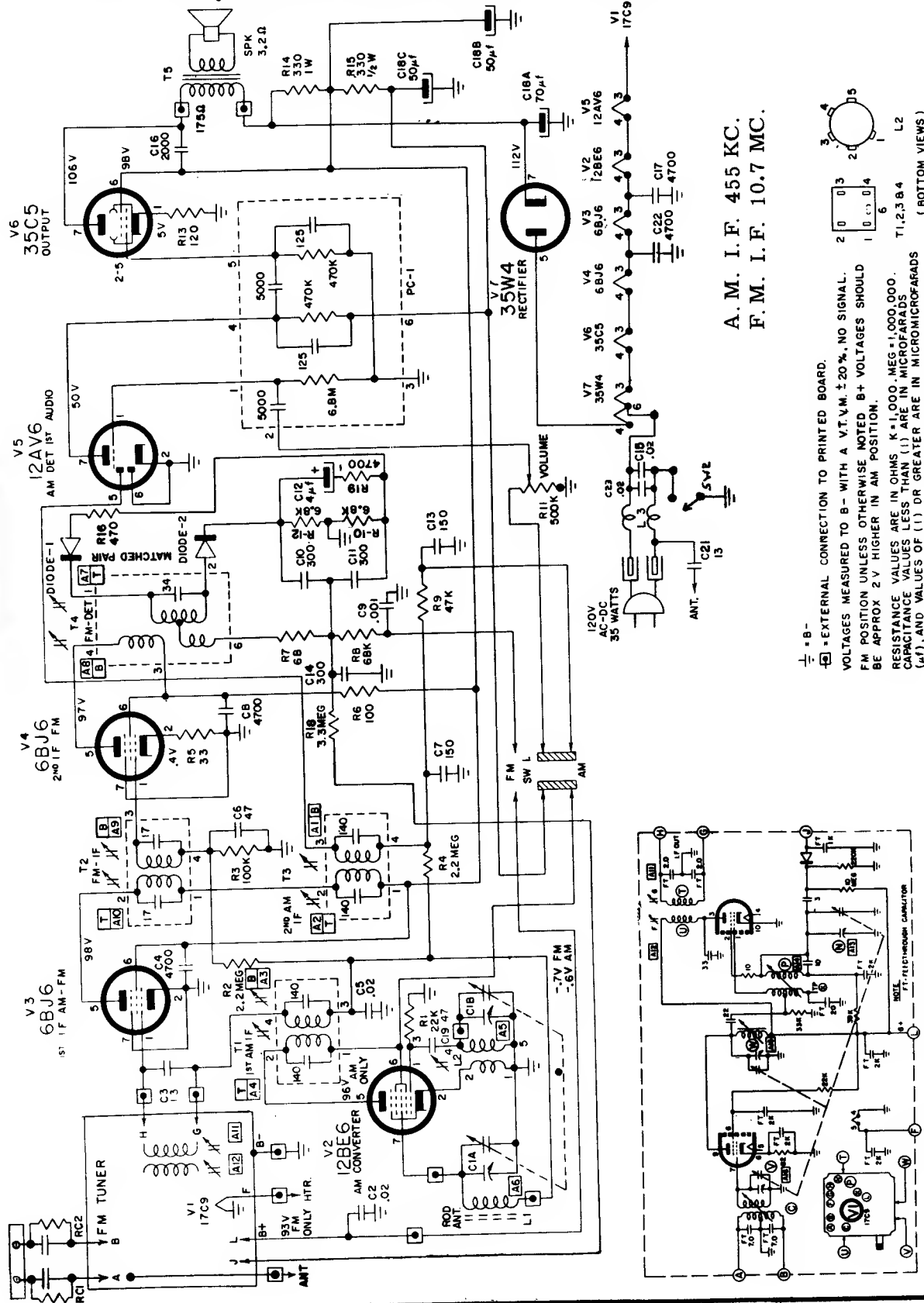

A. M. I. F. 455 KC.
F. M. I. F. 10.7 MC.

* B - EXTERNAL CONNECTION TO PRINTED BOARD.
VOLTAGES MEASURED TO B - WITH A V.T.V.M. ± 20%, NO SIGNAL.
FM POSITION UNLESS OTHERWISE NOTED. B+ VOLTAGES SHOULD BE APPROX 2V HIGHER IN AM POSITION.
RESISTANCE VALUES ARE IN OHMS. K=1,000. MEG=1,000,000.
CAPACITANCE VALUES LESS THAN (1) ARE IN MICROFARADS (µf), AND VALUES OF (1) OR GREATER ARE IN MICROMICROFARADS (µµf) UNLESS OTHERWISE INDICATED.

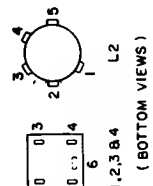

TUNER SCHEMATIC

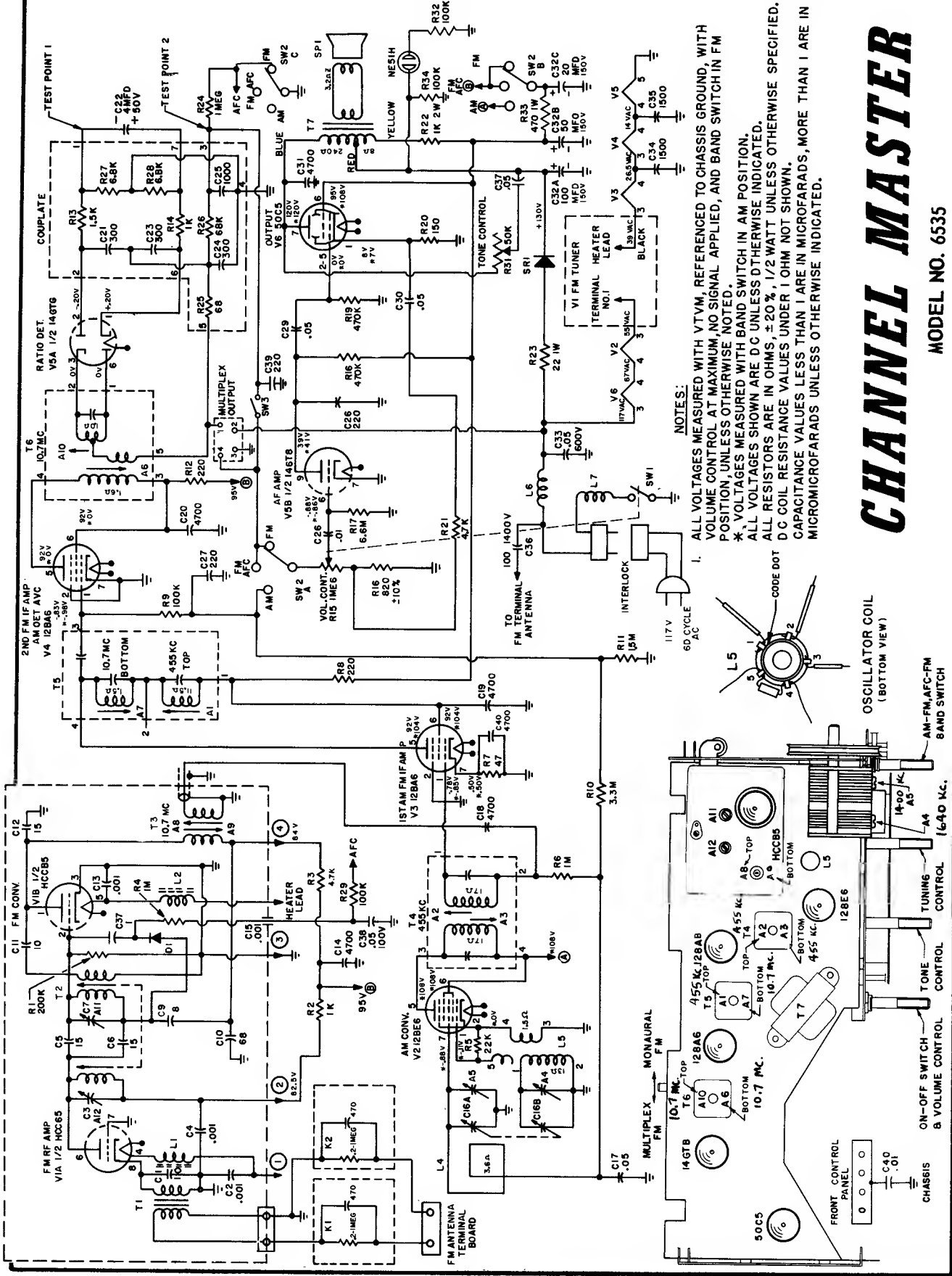

NOTES:

- ALL VOLTAGES MEASURED WITH VTVM, REFERENCED TO CHASSIS GROUND, WITH VOLUME CONTROL AT MAXIMUM, NO SIGNAL APPLIED, AND BAND SWITCH IN FM POSITION, UNLESS OTHERWISE NOTED.
- *1 VOLTAGES MEASURED WITH BAND SWITCH IN AM POSITION.
- *2 VOLTAGES SHOWN ARE DC UNLESS OTHERWISE INDICATED.
- ALL RESISTORS ARE IN OHMS, ±20%, 1/2 WATT UNLESS OTHERWISE SPECIFIED.
- DC COIL RESISTANCE VALUES UNDER 1 OHM NOT SHOWN.
- CAPACITANCE VALUES LESS THAN 1 ARE IN MICROFARADS, MORE THAN 1 ARE IN MICROMICROFARADS UNLESS OTHERWISE INDICATED.

CHANNEL MASTER

MODEL NO. 6535

DELMONICO

MODEL 8B-2

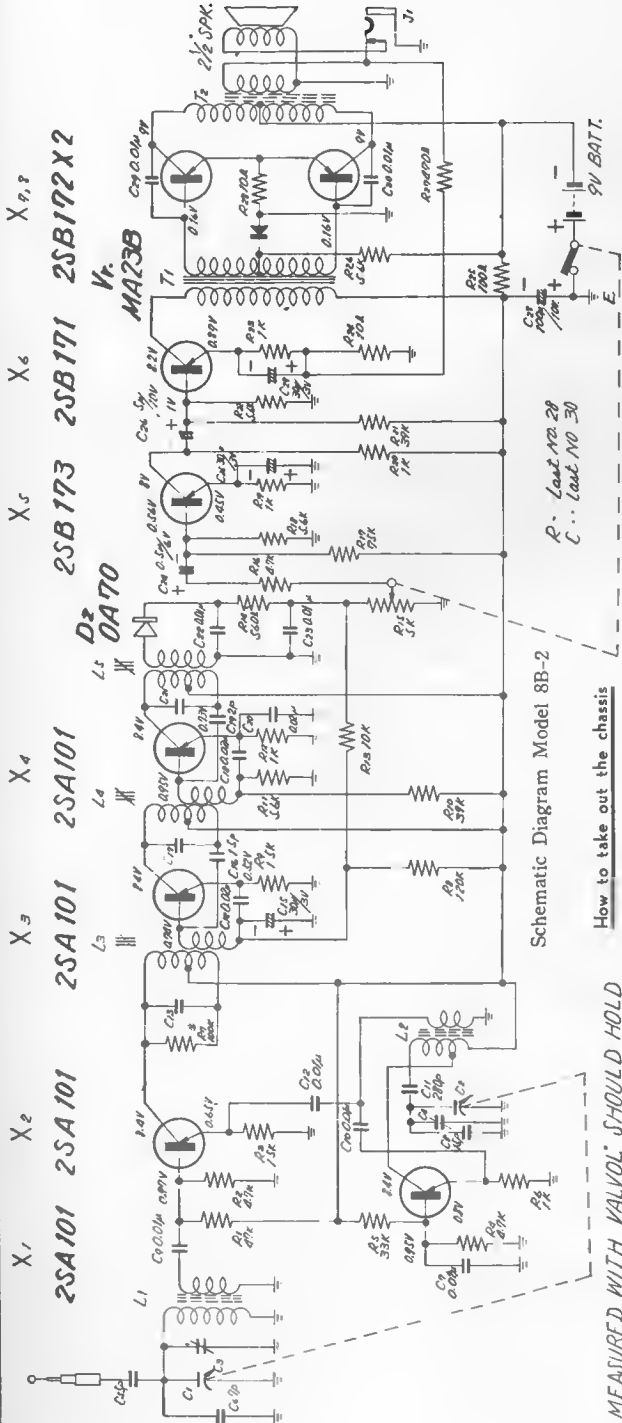

Schematic Diagram Model 8B-2
 How to take out the chassis
 P - Lead No. 28
 C - Lead No. 30

VOLTAGES MEASURED WITH VALVOL SHOULD HOLD WITH IN ±20% WITH NEW BATTERY.

ADJ. RESISTOR

How to fit the dial rope

1. Open the back cover of cabinet with coin or driver and remove the 3 screws A, B, C.

Set the variable Capacitor on maximum capacity, fix the dial drum as shown figure and fit the dial rope in accordance with arrow marks.

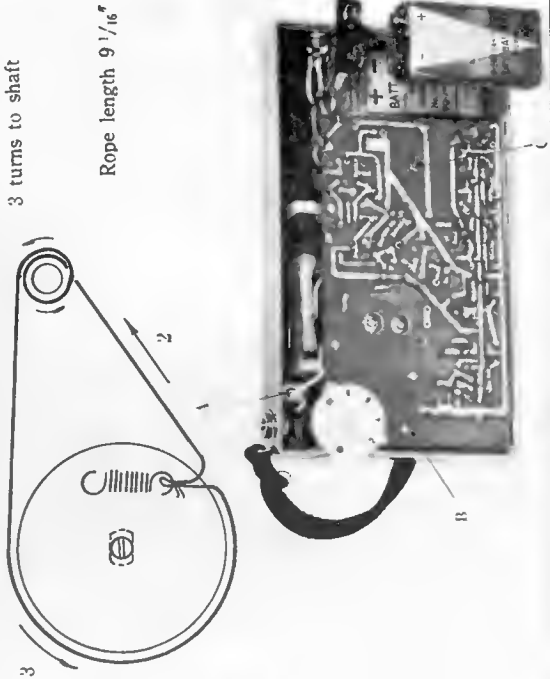

Step	Frequency Band	Frequency	Input Given to	Places to be Regulated	Dial Pointer Setting
1	I F	455 KC	Base of X ₁ through 0.01 μF	L ₃ , L ₄ , L ₅	Fully Open
2		535 KC	Use the standard Loop	L ₂	Max.
3	M W	1680 KC	" "	C ₄	Fully Open
4			Repeat the step 2, 3		
5		620 KC	Use the standard Loop	L ₁	620kc Signal
6	M W	1400 KC	" "	C ₃	1400kc Signal
7			Repeat the step 5, 6		

Note: Output power (at the terminal of voice coil) is kept on always about 10mW.

Delco Radio

BUICK Model 980463
 CADILLAC Model 7282315
 CORVETTE Model 985396
 OLDSMOBILE Model 982137

IF RADIO IS POWERED BY BATTERY ELIMINATOR, USE 16 VOLTS FOR PROPER SOLENOID ACTION.

(Continued on the next page adjacent at right)

NOTE: ILLUS. 74 IS FUSE RESISTOR. OPEN FUSE RESISTOR MAKES TRANSISTOR COLLECTOR VOLTAGE 0 VOLTS.

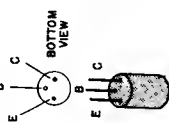
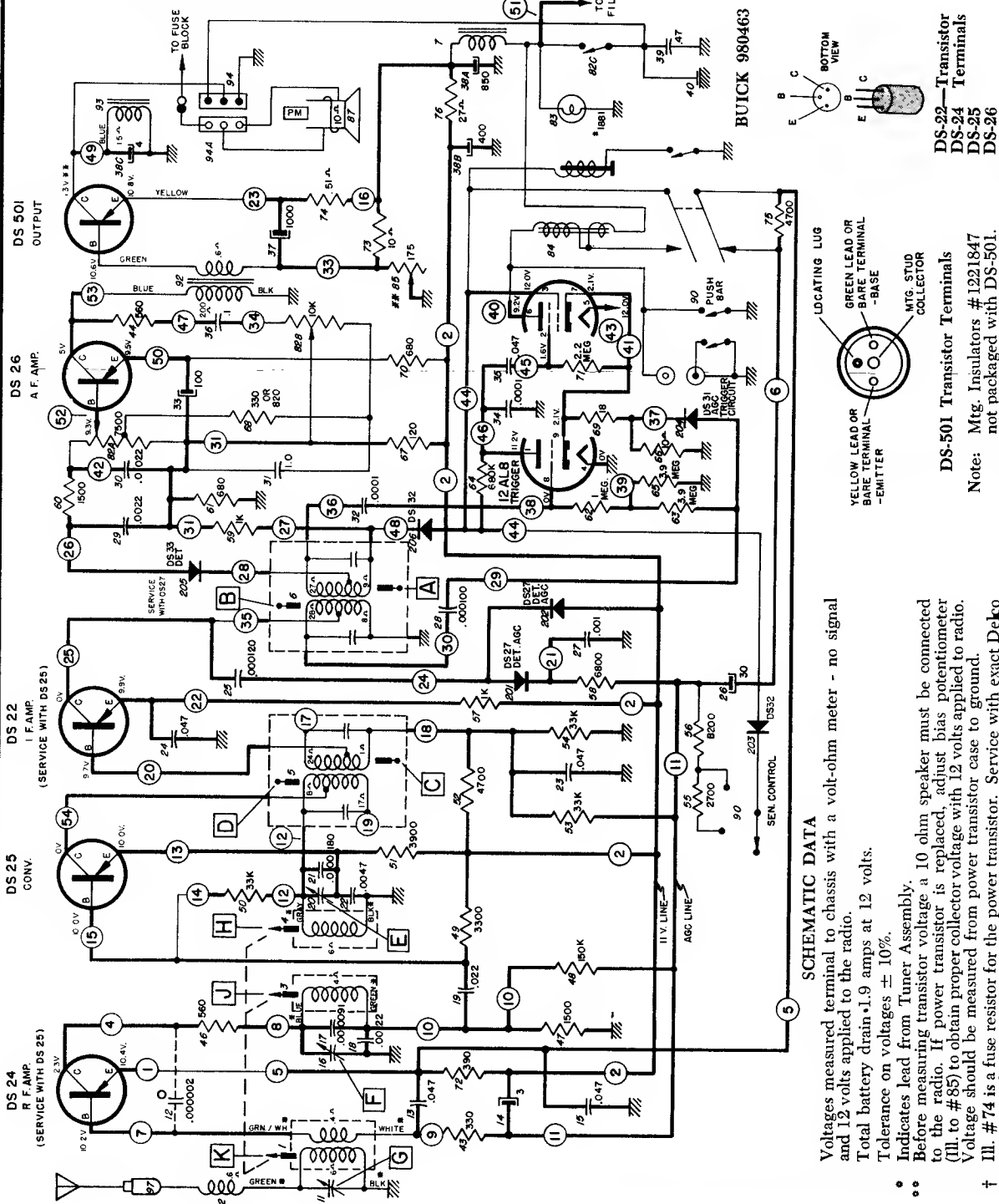

DS-22—Transistor
 DS-24 Terminals
 DS-25
 DS-26

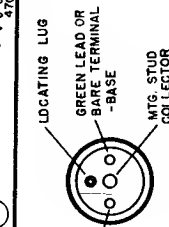

DS-501 Transistor Terminals
 Note: Mfg. Insulators #1221847 not packaged with DS-501.
 PRINTED CIRCUIT SHOWN IN HEAVY LINES

NUMBERS ON PRINTED CIRCUIT BOARD CORRESPOND WITH NUMBERS IN CIRCLES ON SCHEMATIC DIAGRAM.

SCHEMATIC DATA

- Voltages measured terminal to chassis with a volt-ohm meter - no signal and 12 volts applied to the radio.
- Total battery drain .1.9 amps at 12 volts.
- Tolerance on voltages $\pm 10\%$.
- † Indicates lead from Tuner Assembly.
- † Before measuring transistor voltage a 10 ohm speaker must be connected to the radio. If power transistor is replaced, adjust bias potentiometer (Ill. to #85) to obtain proper collector voltage with 12 volts applied to radio. Voltage should be measured from power transistor case to ground.
- † Ill. #74 is a fuse resistor for the power transistor. Service with exact Deko service replacement.
- † Printed on circuit board.
- † Trigger tube voltages are read with a VTVM and with the tuner seeking.
- CAUTION: Only a 10 ohm speaker should be used on this radio.

VOLUME R-24, MOST-OFTEN-NEEDED 1964 RADIO SERVICING INFORMATION

DELCO

BUICK 980463
 CADILLAC 7282315
 CORVETTE 985396
 OLDSMOBILE 982137

(Continued)

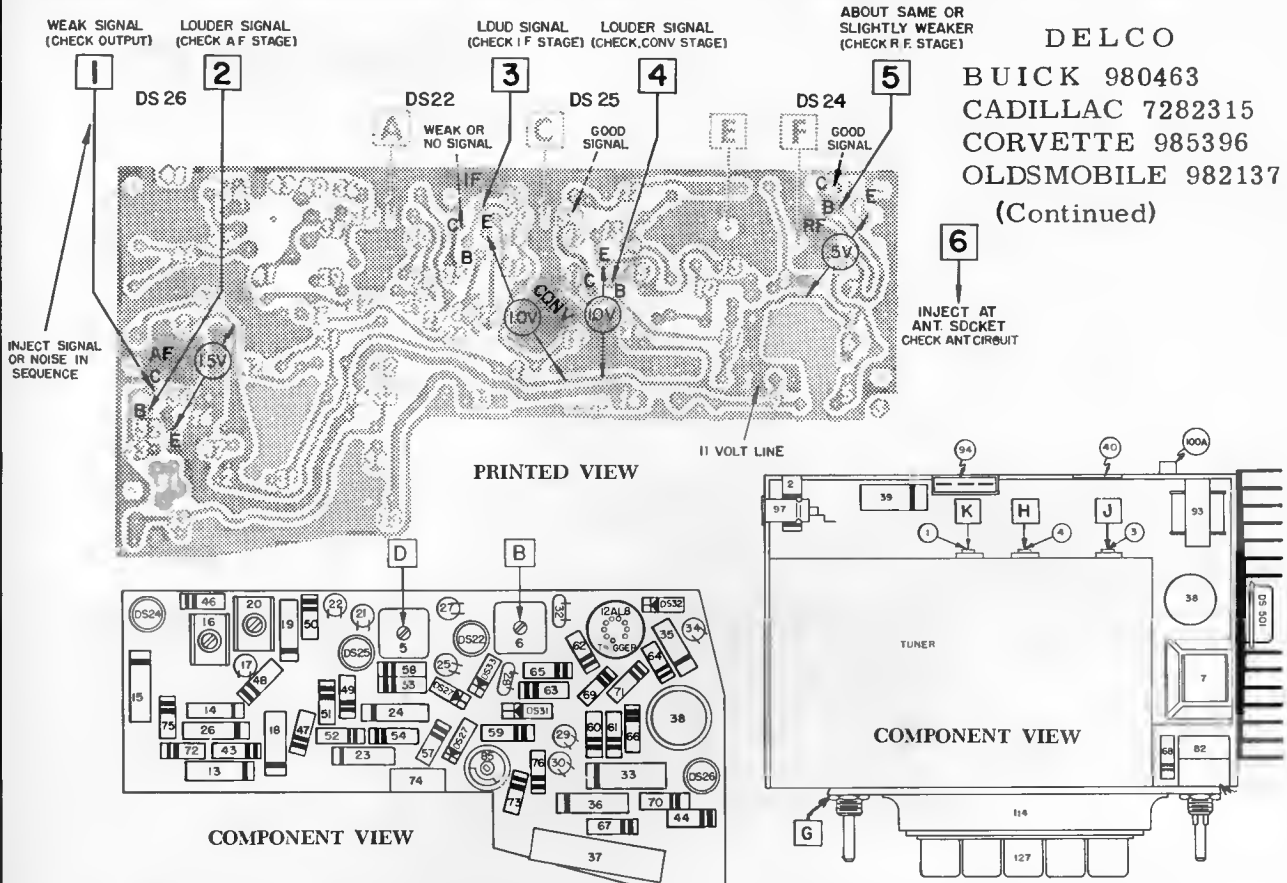

IMPORTANT: With the radio installed and the car antenna plugged in, adjust the antenna trimmer "G" for maximum volume with the radio tuned to a **WEAK** station between 600 KC and 1000 KC. (Prevents fading and station mixing). The antenna trimmer is located behind the dummy knob and can be adjusted from the front of the radio.

ALIGNMENT PROCEDURE

- A. Connections
 - 1. A. C. Voltmeter Across speaker voice coil
 - 2. Signal Generator Connect capacitor (see chart below for value) in series with generator lead and connect to antenna terminal. Connect generator ground lead to chassis.
- B. Preliminary Adjustments (in order)
 - 1. Volume control Maximum volume
 - 2. Radio Tuning Pointer Extreme right end of dial
 - 3. Radio tuner cores Rear of core 1 1/8" from end of coil form. Adjustment is made using a plastic alignment tool marked 1 1/8" from end.
- C. Alignment Adjustments
 - 1. Generator Output Readable A.C. voltage (1/2 to 1 volt) across speaker voice coil
 - 2. Proceed according to chart - - -

Step	Capacitor	Signal Generator Frequency	Tune Receiver to	Adjust in Sequence
a.	.1 mfd.	262 KC	Hi freq. stop	A, B, C, D
b.	82 mmfd.	1615 KC	Hi freq. stop	E, F, G
c.	82 mmfd.	600 KC	Sig. Gen. Freq.	J, K
d.	82 mmfd.	1615 KC	Sig. Gen. Freq.	F, G
e.	82 mmfd.	900 KC	Sig. Gen. Freq.	Pointer Adjustment

- 3. Pointer Adjustment With incoming 900 KC signal, insert a screwdriver in the slot of the pointer calibration adjustment link (illustration #124) and twist until the pointer is in line with "9" on the radio dial.
- 4. Antenna Adjustment See notice above

Delco

(Continued on the next page)

DELCO, for complete list of models and additional data see next page at right.

Voltages Measured to Chassis with a VOM - Antenna Disconnected and 12 Volts Applied to Radio.

Total Battery Drain 1.3 Amps at 12 Volts.

Voltage across Fuse Resistor for DS-501. Open Fuse Resistor Causes 0 Volts on DS-501 collector. Service With Exact Delco Part.

When DS-501 is Replaced, Set Bias Pot (Illus. 97) for Reading of 1.3V. on Transistor Case with 12 Volts Applied to Radio and 10 Ohm Speaker Connected.

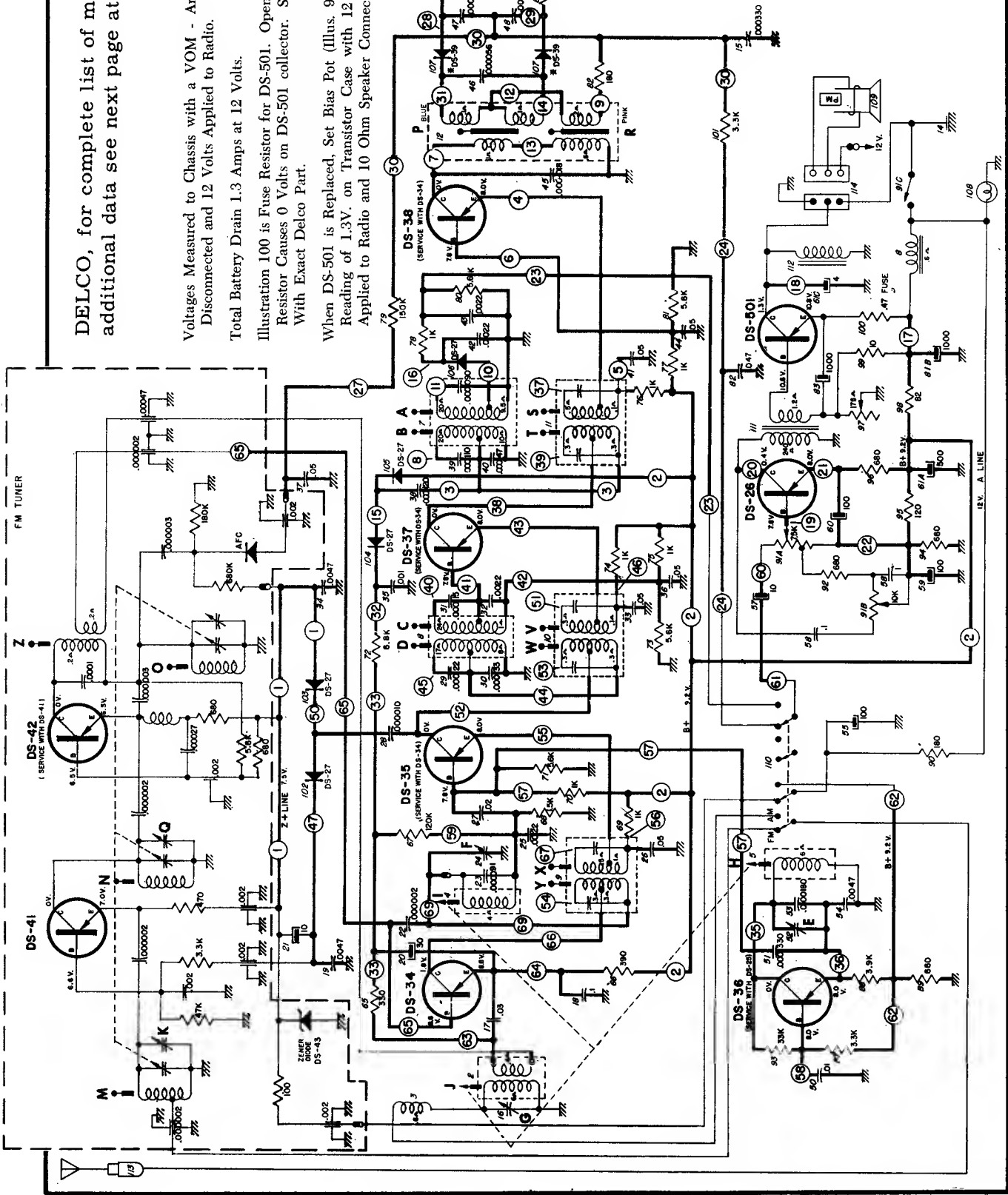

Delco

BUICK Models 980626, 980635
 CADILLAC Model 7283295
 CHRYSLER Model 333
 DODGE Models 331, 332
 PLYMOUTH Model 300
 CORVETTE Model 985686
 OLDSMOBILE Model 982212

(Continued from preceding page adjacent at left)

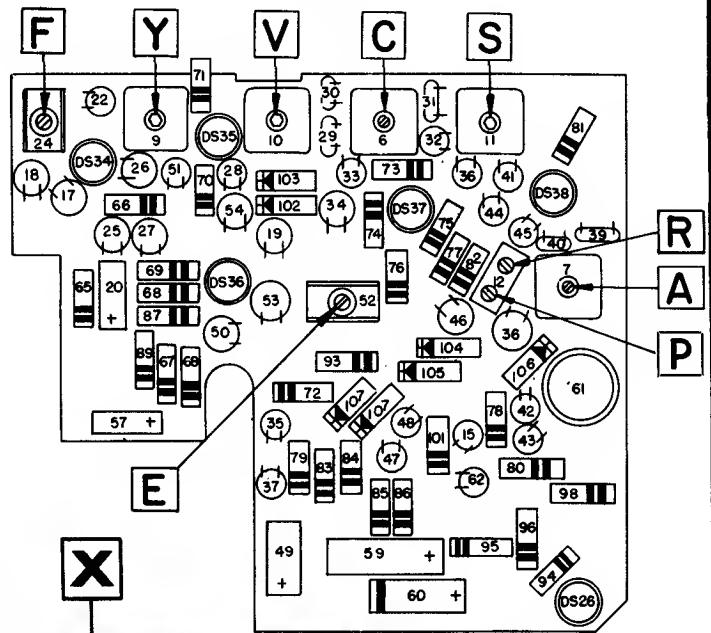

CIRCUIT BOARD
(Parts View)

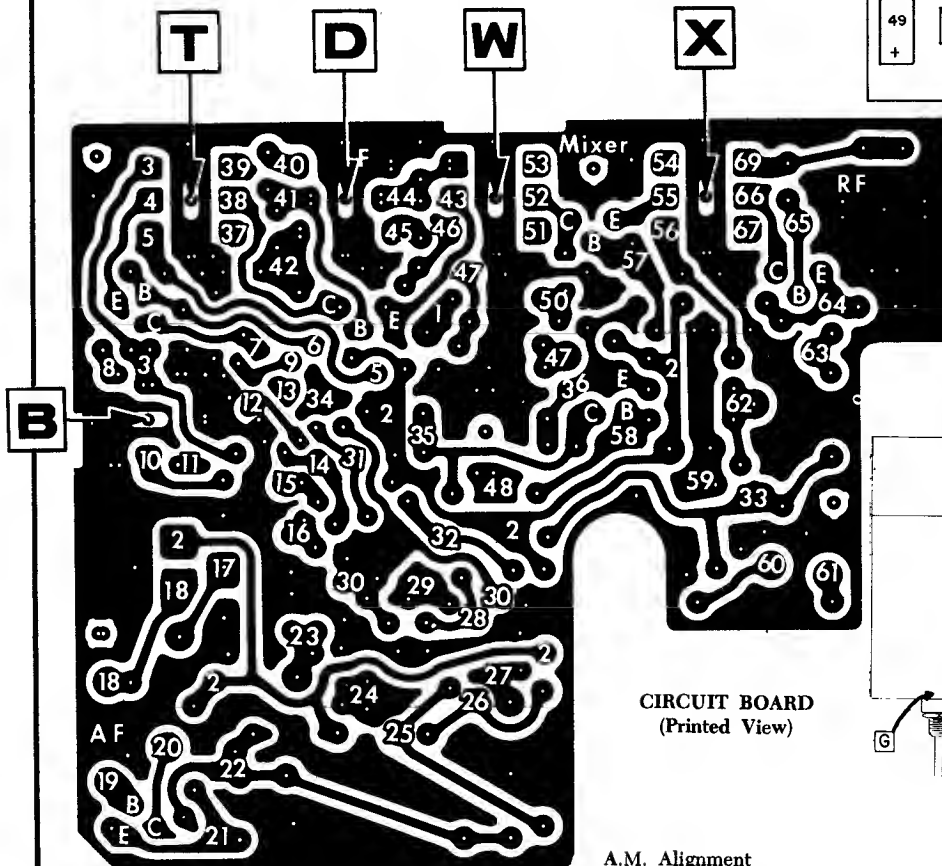

CIRCUIT BOARD
(Printed View)

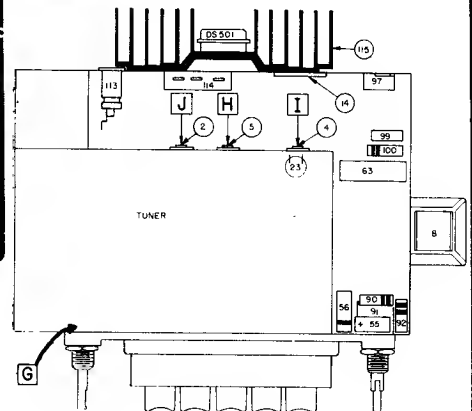

COMPONENT VIEW

A.M. Alignment

Step	Capacitor	Signal Generator Frequency	Tune Receiver to	Adjust for Maximum in Sequence
a.	.1 mfd.	262 KC	Hi freq. stop	A, B, C, D
b.	56 mmfd.	1615 KC	Hi freq. stop	E, F, G
c.	56 mmfd.	600 KC	Sig. Gen. Freq.	I, J
d.	56 mmfd.	1615 KC	Sig. Gen. Freq.	F, G
e.	56 mmfd.	900 KC	Sig. Gen. Freq.	Pointer Adjustment

F.M. Alignment

Connections

D.C. Voltmeter Positive lead to Orange wire (island #24)
 Negative lead to chassis. Use Lowest Scale.

Generator Output (AM with no modulation or FM) set to 10.7 mc. Connect 56 mmfd. capacitor in series with generator lead and connect to antenna terminal. Connect generator ground lead to chassis.

Alignment Adjustments

1. Adjust in sequence for maximum voltage R, S, T, V, W, X, Y, Z
2. Ratio detector transformer Remove generator and adjust blue (P) slug for zero volts.
3. Tuner K, Q for maximum on a weak station near the top of the dial with antenna connected.

Delco Radio

CHEVROLET Models 985431, 985453
 CORVAIR Models 985447, 985443
 OLDSMOBILE Model 982149
 STUDEBAKER Models AC-3351, AC-3353
 PONTIAC Model 983874

(Continued on the next page adjacent at right)

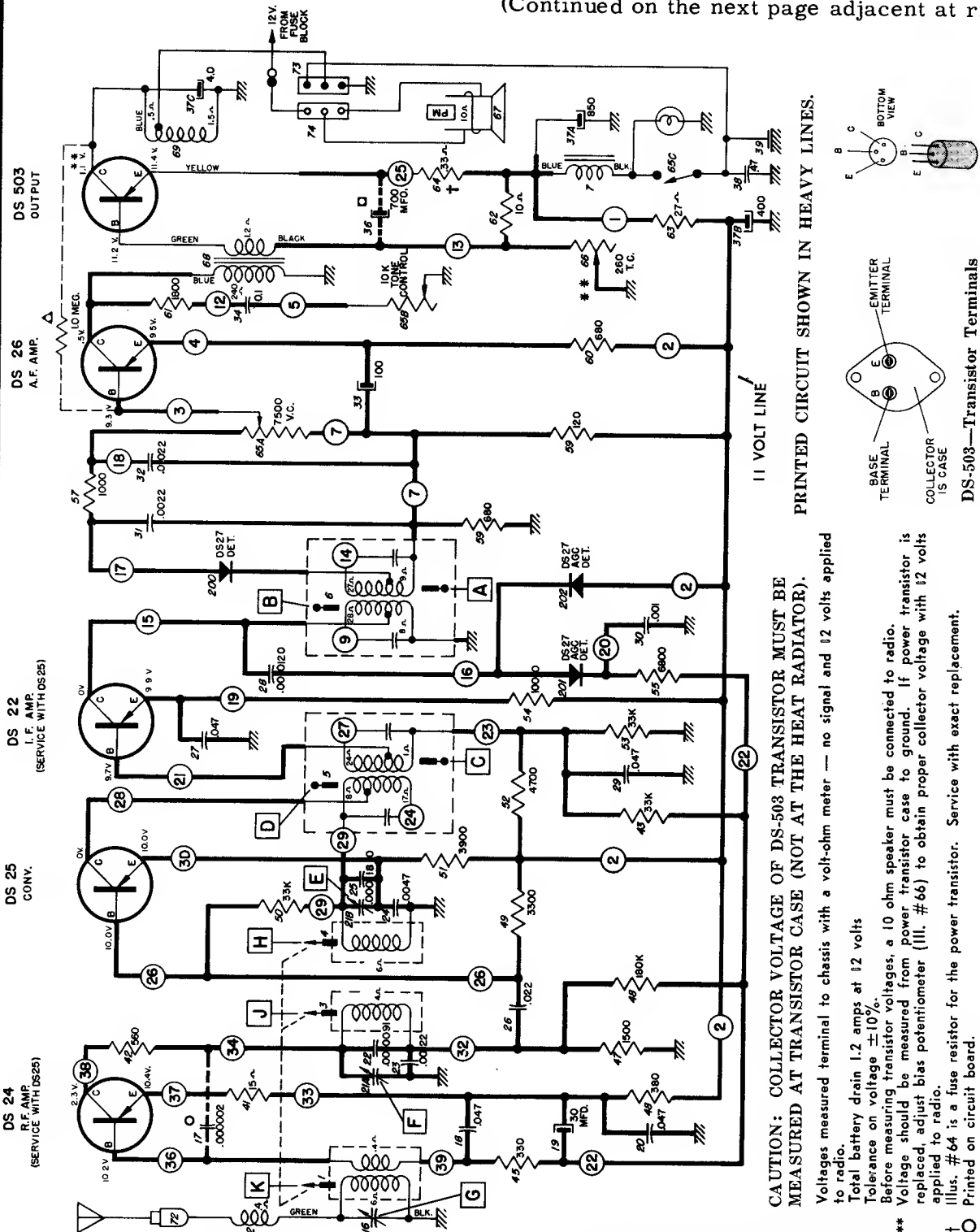

CAUTION: COLLECTOR VOLTAGE OF DS-503 TRANSISTOR MUST BE MEASURED AT TRANSISTOR CASE (NOT AT THE HEAT RADIATOR).

Volts measured terminal to chassis with a volt-ohm meter — no signal and 12 volts applied to radio.
 Total battery drain 1.2 amps at 12 volts
 Tolerance on voltage $\pm 10\%$.
 Before measuring transistor voltages, a 10 ohm speaker must be connected to radio.
 Voltage should be measured from power transistor case to ground. If power transistor is replaced, adjust bias potentiometer (Ill. #66) to obtain proper collector voltage with 12 volts applied to radio.
 Illus. #64 is a fuse resistor for the power transistor. Service with exact replacement.
 † Printed on circuit board.

Will not appear in all radios.
 Will not appear in all radios.
CAUTION: Only a 10 ohm speaker should be used on this radio.

PRINTED CIRCUIT SHOWN IN HEAVY LINES.

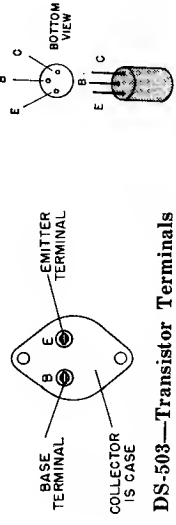

DS-503—Transistor Terminals
 Note: Mfg. Insulators #1221813 not packaged with DS-503.
DS-26—Transistor Terminals
DS-25

VOLUME R-24, MOST-OFTEN-NEEDED 1964 RADIO SERVICING INFORMATION

DELCO, various models, continued from preceding page adjacent at left.

ALIGNMENT PROCEDURE

A. C. Voltmeter—Across speaker voice coil.

Signal Generator—Connect capacitor (see chart below for value) in series with generator lead and connect to antenna terminal. Connect generator ground lead to chassis.

Volume control—Maximum volume

Radio Tuning Pointer—Extreme right end of dial.

Radio tuner cores—Rear of core 1 1/8" from end of coil form. Adjustment is made using a plastic alignment tool marked 1 1/8" from end.

Generator Output—Readable A.C. voltage (1/2 to 1 volt) across speaker voice coil

Proceed according to chart—

STEP	CAPACITOR	SIGNAL GENERATOR FREQUENCY	TUNE RECEIVER TO	ADJUST IN SEQUENCE
a.	.1 mfd.	262 KC	Hi freq. stop	A, B, C, D
b.	68 mmfd.	1615 KC	Hi freq. stop	E, F, G
c.	68 mmfd.	600 KC	Sig. Gen. Freq.	J, K
d.	68 mmfd.	1615 KC	Sig. Gen. Freq.	F, G
e.	68 mmfd.	900 KC	Sig. Gen. Freq.	Pointer Adjustment

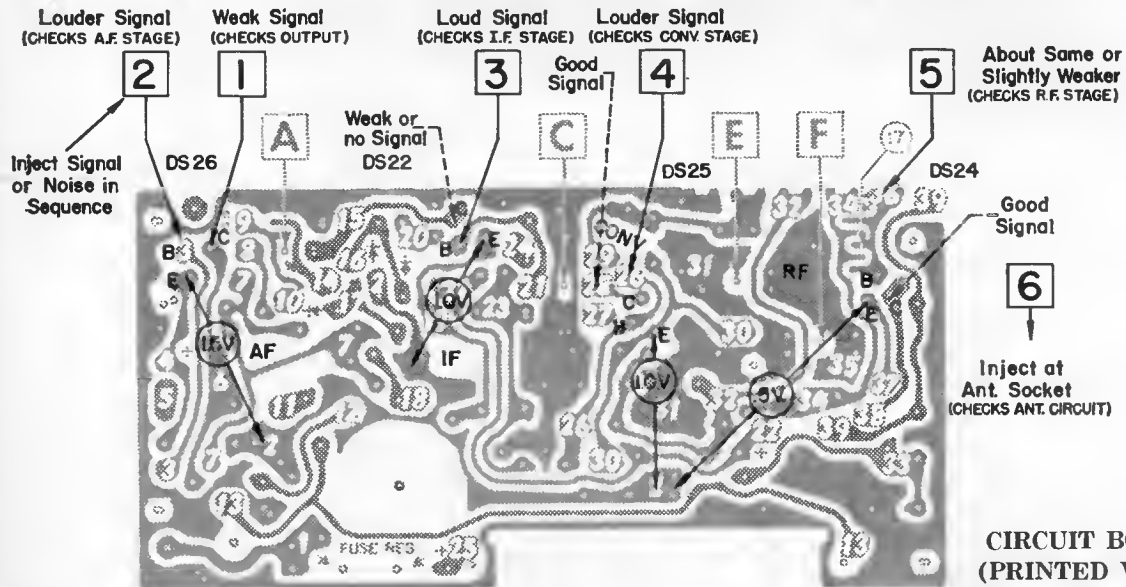

NUMBERS IN SQUARES ARE MAJOR TEST POINTS FOR STAGE ISOLATION—INJECT SIGNAL GENERATOR.

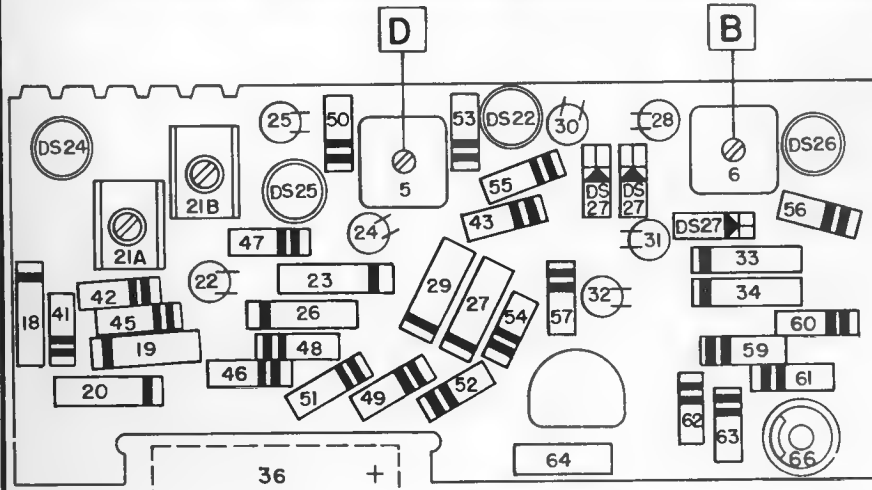

CIRCUIT BOARD COMPONENT VIEW

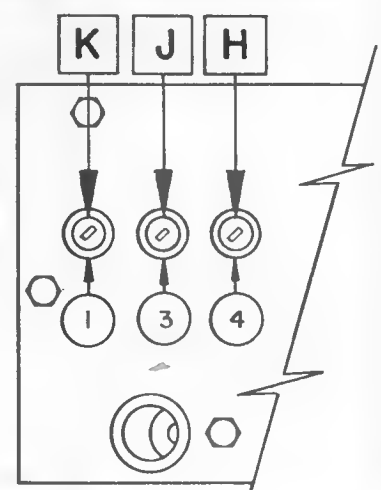

IRON CORE ALIGNMENT

Delco

BUICK Models 980462, 980464
 CHEVROLET 985432, 985455, 985471
 CORVAIR 985449, GMC Truck 2234003
 OLDSMOBILE Model 982136
 PONTIAC Models 983873, 983875
 STUDEBAKER AC-3352, AC-3354, AC-3377

(Continued on the next page at right)

CAUTION: COLLECTOR VOLTAGE OF DS-501 TRANSISTOR SHOULD BE MEASURED AT TRANSISTOR CASE (NOT AT THE HEAT RADIATOR).

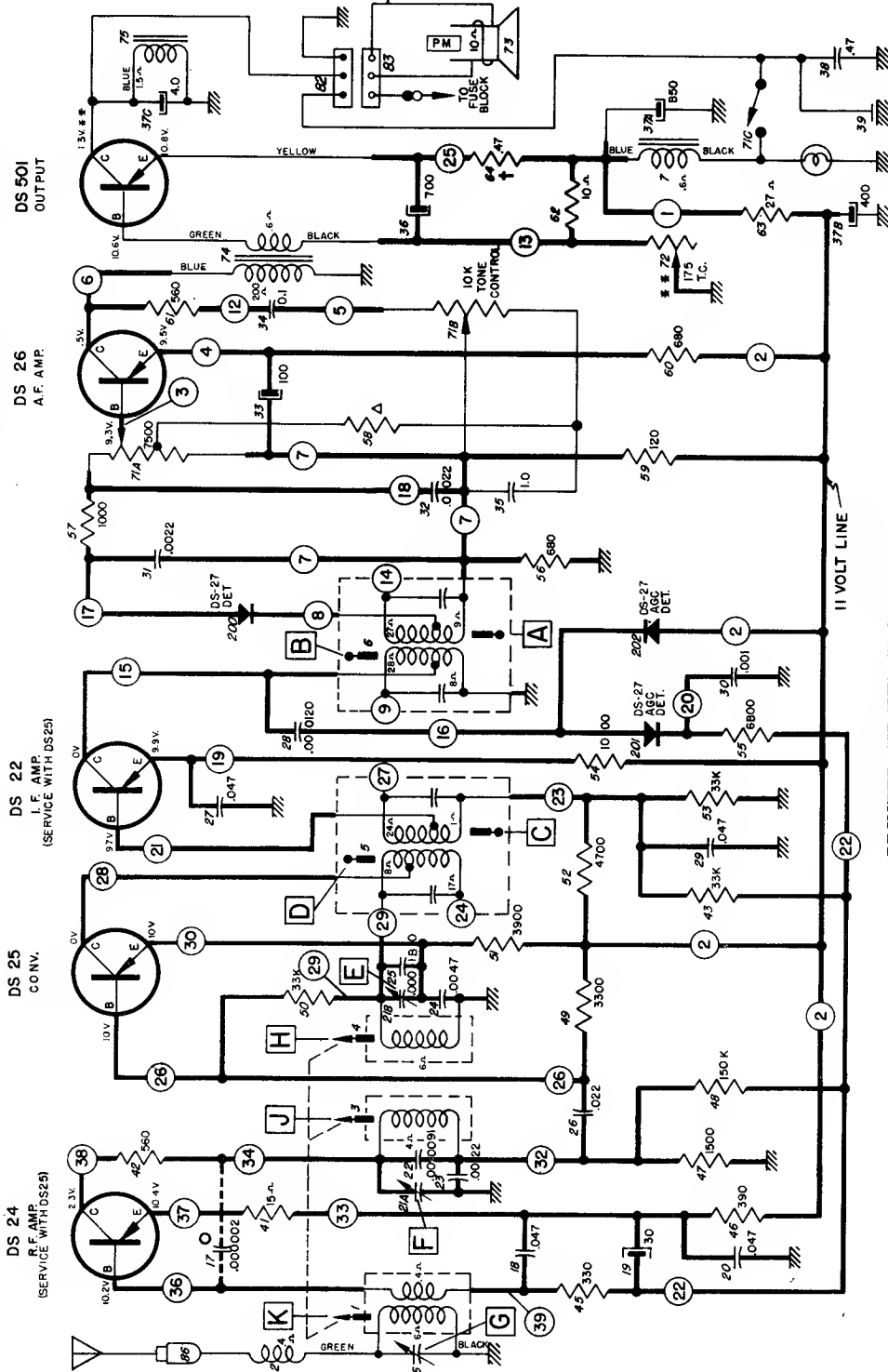

PRINTED CIRCUIT SHOWN IN HEAVY LINES.

Voltages measured terminal to chassis with a volt-ohm meter — no signal and 12 volts applied to radio.

Total battery drain 1.2 amps at 12 volts

Tolerance on voltage ±10%.

Before measuring transistor voltages, a 10 ohm speaker must be connected to radio. Voltage should be measured from power transistor case to ground. If power transistor is replaced, adjust bias potentiometer (illus. #72) to obtain proper collector voltage with 12 volts applied to radio.

Resistor illus. #58 is 330 ohms.

† illus. #64 is a fuse resistor for the power transistor. Service with exact replacement.

○ Printed on circuit board.

CAUTION: Only a 10 ohm speaker should be used on this radio.

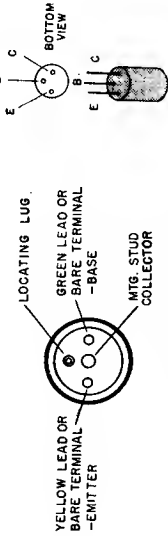

DS-22—Transistor
 DS-24 Terminals
 DS-25
 DS-26

DS-501 Transistor Terminals
 Note: Mtg. Insulators #1221807 not packaged with DS-501.

DELCO, Material on various models continued from preceding page at left

ALIGNMENT PROCEDURE

A. C. Voltmeter—Across speaker voice coil.

Signal Generator—Connect capacitor (see chart below for value) in series with generator lead and connect to antenna terminal. Connect generator ground lead to chassis.

Volume control—Maximum volume

Radio Tuning Pointer—Extreme right end of dial.

Radio tuner cores—Rear of core 1 3/8" from end of coil form. Adjustment is made using a plastic alignment tool marked 1 3/8" from end.

Generator Output—Readable A.C. voltage (1/2 to 1 volt) across speaker voice coil

Proceed according to chart—

STEP	CAPACITOR	SIGNAL GENERATOR FREQUENCY	TUNE RECEIVER TO	ADJUST IN SEQUENCE
a.	.1 mfd.	262 KC	Hi freq. stop	A, B, C, D
b.	82 mmfd.	1615 KC	Hi freq. stop	E, F, G
c.	82 mmfd.	600 KC	Sig. Gen. Freq.	J, K
d.	82 mmfd.	1615 KC	Sig. Gen. Freq.	F, G
e.	82 mmfd.	900 KC	Sig. Gen. Freq.	Pointer Adjustment

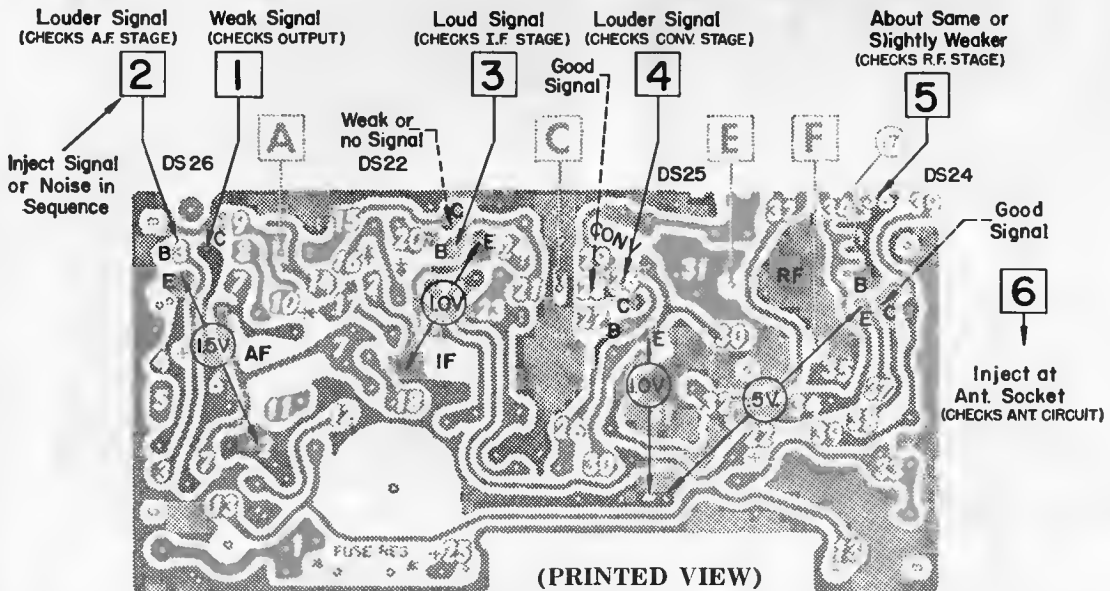

NUMBERS IN SQUARES ARE MAJOR TEST POINTS FOR STAGE ISOLATION—INJECT SIGNAL GENERATOR.

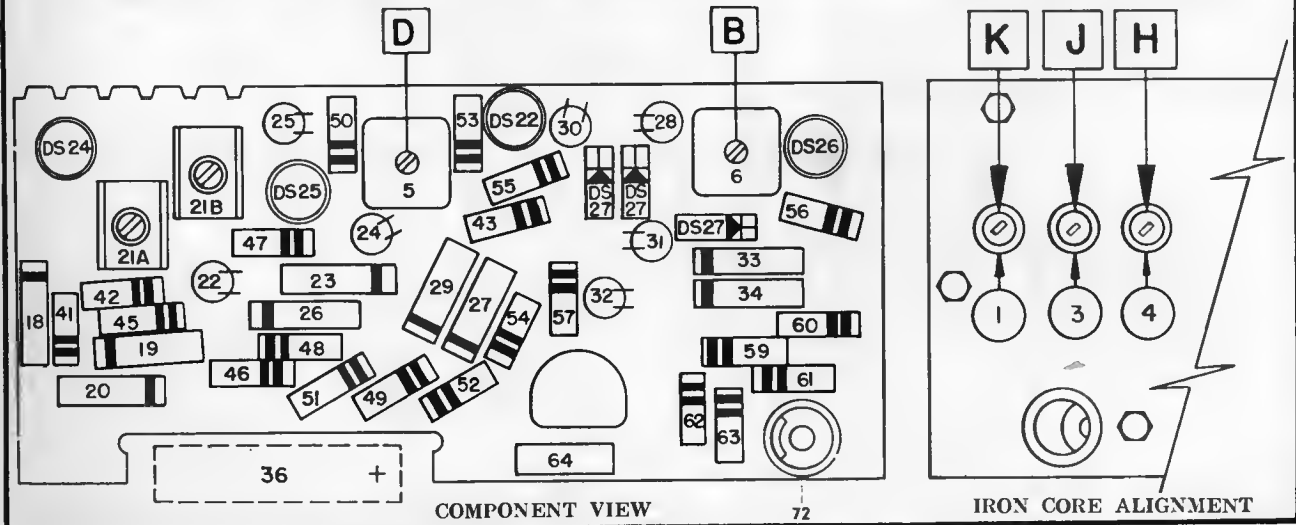

DELCO Buick Model 980655 Diagram, Continued on next page at right

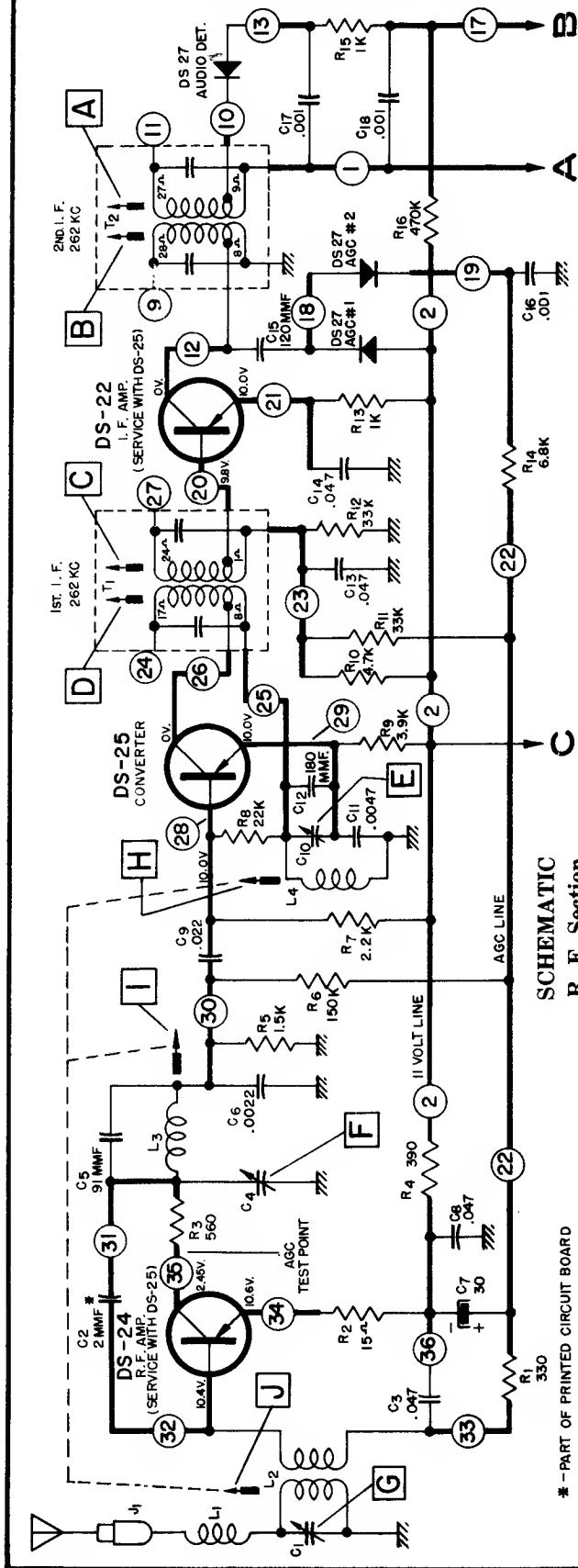

SCHEMATIC R.F. Section

* - PART OF PRINTED CIRCUIT BOARD

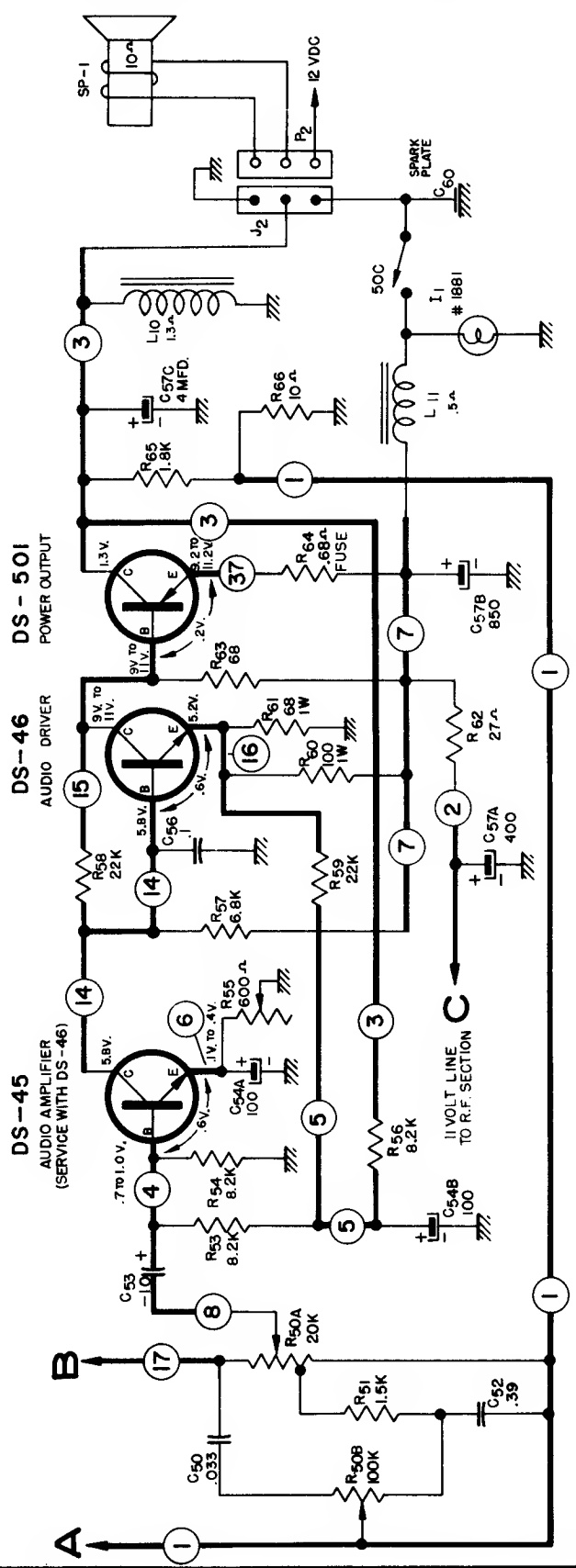

DELCO Buick Model 980655 Service Material, Continued from preceding page

Tolerance on voltage $\pm 10\%$, Capacitors in mfd., Resistors in ohms.
 Before measuring transistor voltages, a 10 ohm speaker must be connected to radio.
 Voltage should be measured from power transistor case to ground. If power transistor is replaced, adjust bias potentiometer (Illus. R-55) to obtain proper collector voltage with 12 volts applied to radio.

CAUTION: Only a 10 ohm speaker should be used on this radio.
 Illus. R-64 is a fuse resistor for the power transistor. Service with exact replacement.
 Voltages measured terminal to chassis with a volt-ohm meter — no signal and 12 volts applied to radio.
 Total battery drain 1.2 amps at 12 volts

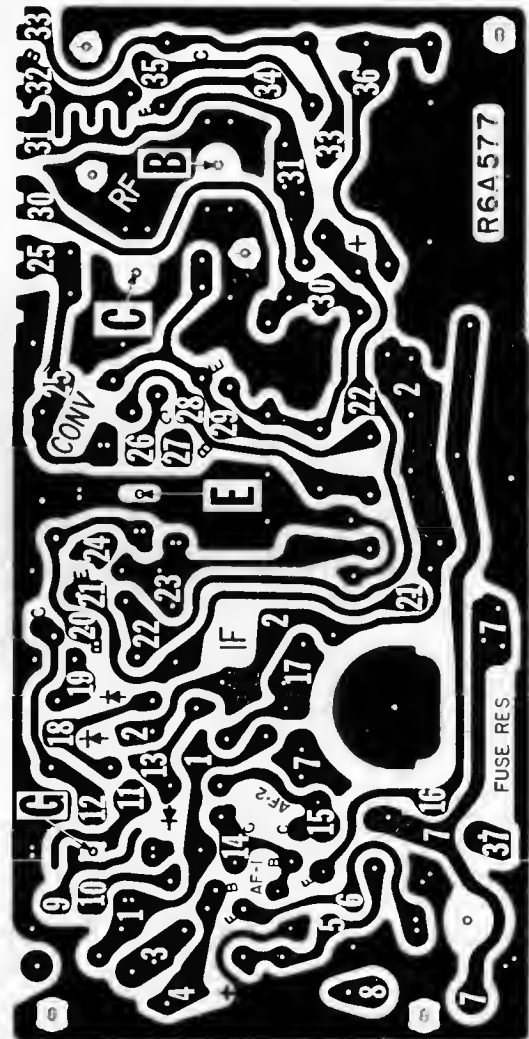

ALIGNMENT PROCEDURE

A. Connections

1. A. C. Voltmeter—Across speaker coil.
2. Signal Generator—Connect capacitor (see chart below for value) in series with generator lead and connect to antenna terminal. Connect generator ground lead to chassis.

B. Preliminary Adjustments (in order)

1. Volume control—Maximum volume
2. Radio Tuning Pointer—Extreme right end of dial.
3. Radio tuner cores—Rear of core $1\frac{1}{2}$ " from end of coil form. Adjustment is made using a plastic alignment tool marked $1\frac{1}{2}$ " from end.

C. Alignment Adjustments

1. Generator Output—Readable A.C. voltage ($\frac{1}{2}$ to 1 volt) across speaker voice coil
2. Proceed according to chart—

STEP	CAPACITOR	SIGNAL GENERATOR FREQUENCY	TUNE RECEIVER TO	ADJUST IN SEQUENCE
a.	.1 mfd.	262 KC	Hi freq. stop	A, B, C, D
b.	82 mmfd.	1615 KC	Hi freq. stop	E, F, G
c.	82 mmfd.	600 KC	Sig. Gen. Freq.	I, J
d.	82 mmfd.	1615 KC	Sig. Gen. Freq.	F, G

IMPORTANT: With the radio installed and the car antenna plugged in, adjust the antenna trimmer "G" for maximum volume with the radio tuned to a weak station between .600 KC and 1000 KC. (Prevents fading and station mixing). The antenna trimmer is located behind the dummy knob and can be adjusted from the front of the radio.

PUSH-PULL AUDIO OUTPUT Q-B, O-9*

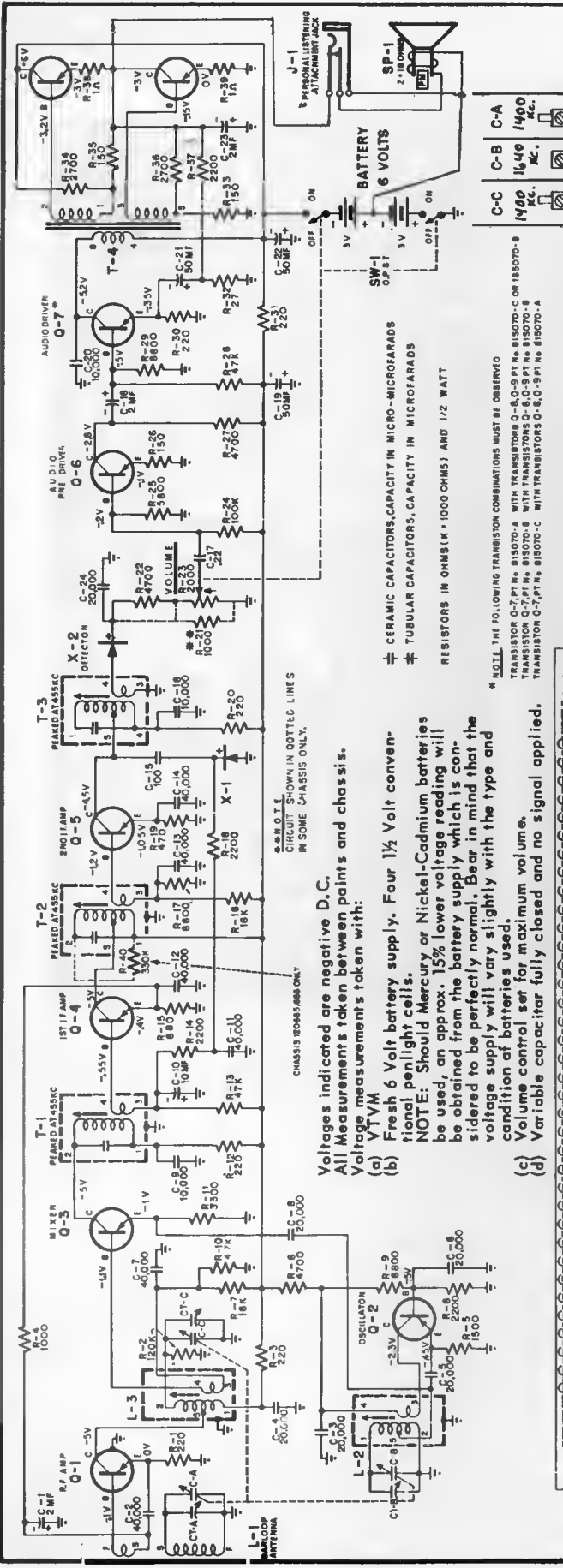

Voltages indicated are negative D.C.
 All Measurements taken between points and chassis.
 Voltage measurements taken with:
 (a) VTVM
 (b) Fresh 6 Volt battery supply. Four 1½ Volt conventional penlight cells.
 NOTE: Should Mercury or Nickel-Cadmium batteries be used, an approx. 15% lower voltage reading will be obtained from the battery supply which is considered to be perfectly normal. Bear in mind that the voltage supply will vary slightly with the type and condition of batteries used.
 (c) Volume control set for maximum volume.
 (d) Variable capacitor fully closed and no signal applied.

± CERAMIC CAPACITORS, CAPACITY IN MICROFARADS
 ≡ TUBULAR CAPACITORS, CAPACITY IN MICROFARADS
 □ RESISTORS IN OHMS (x 1000 OHMS) AND ½ WATT

* NOTE THE FOLLOWING TRANSISTOR COMBINATIONS MUST BE OBSERVED
 TRANSISTOR Q-7, PT No. 815070-A WITH TRANSISTORS Q-8, Q-9, PT No. 815070-B
 TRANSISTOR Q-7, PT No. 815070-B WITH TRANSISTORS Q-8, Q-9, PT No. 815070-C
 TRANSISTOR Q-7, PT No. 815070-C WITH TRANSISTORS Q-8, Q-9, PT No. 815070-A

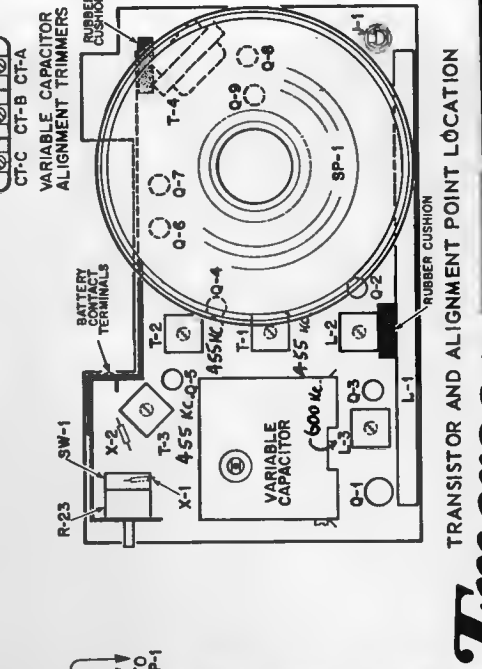

Emerson
 TRANSISTOR AND ALIGNMENT POINT LOCATION

MODELS: 911, 990
 CHASSIS: 120486,
 120665, 120666

MODEL: 991
 CHASSIS: 120713

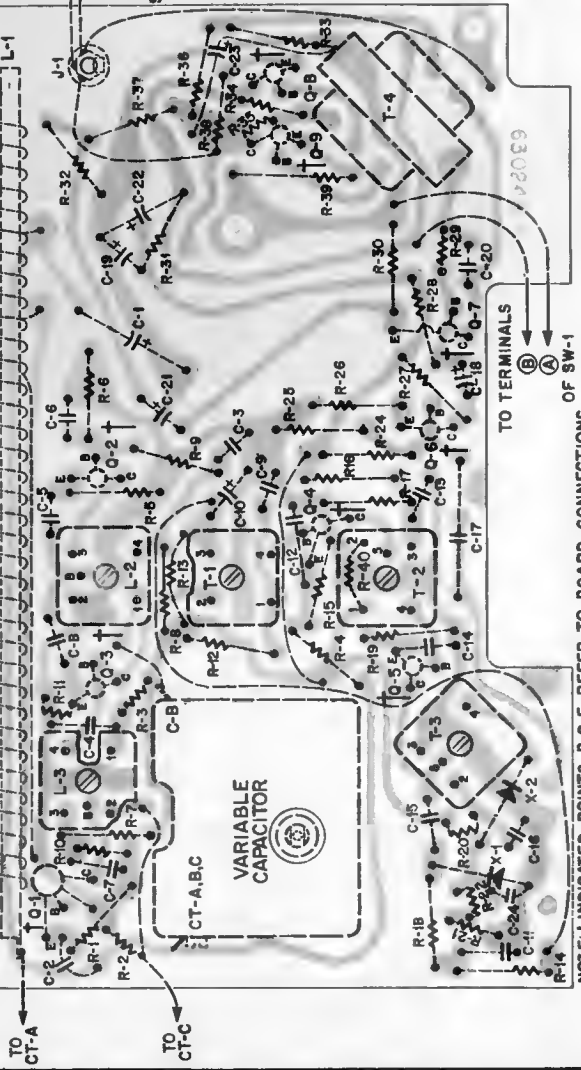

NOTE: † INDICATED POINTS B, C, E REFER TO BOARD CONNECTIONS FOR THE CORRESPONDING TRANSISTOR TERMINALS
 ‡ ETCHED PRINTED CIRCUIT BOARD (BOTTOM VIEW)

VOLUME R-24, MOST-OFTEN-NEEDED 1964 RADIO SERVICING INFORMATION

EMERSON Models G-1700, G-1709, using Chassis 120685, and Model G-1713 using Chassis 120700

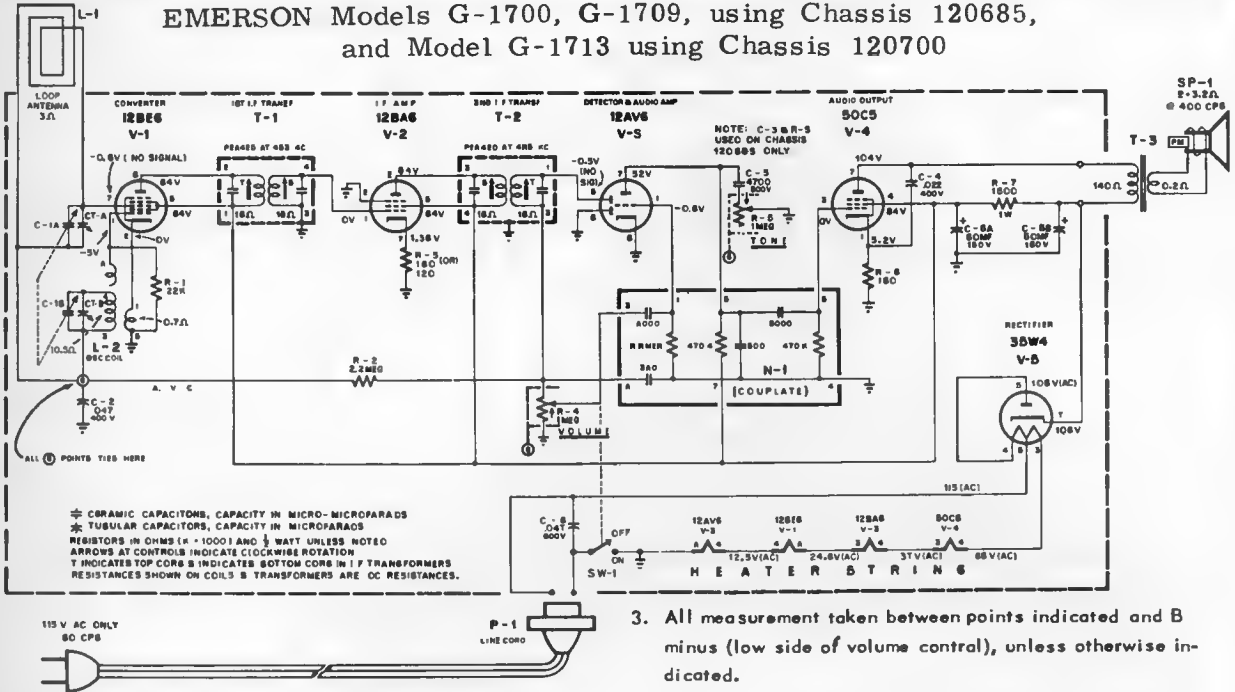

CONDITIONS FOR VOLTAGE AND RESISTANCE READINGS

1. Voltages indicated are positive D.C., resistances in ohms unless otherwise indicated.
2. Measurements taken with Voltomyst or equivalent VTVM.

3. All measurement taken between points indicated and B minus (low side of volume control), unless otherwise indicated.
4. Voltage readings indicated on schematic were taken with:
 - (A) Line voltage set at 115 volts AC,
 - (B) Volume control set for minimum volume,
 - (C) Tuning capacitor fully closed and no signal applied.

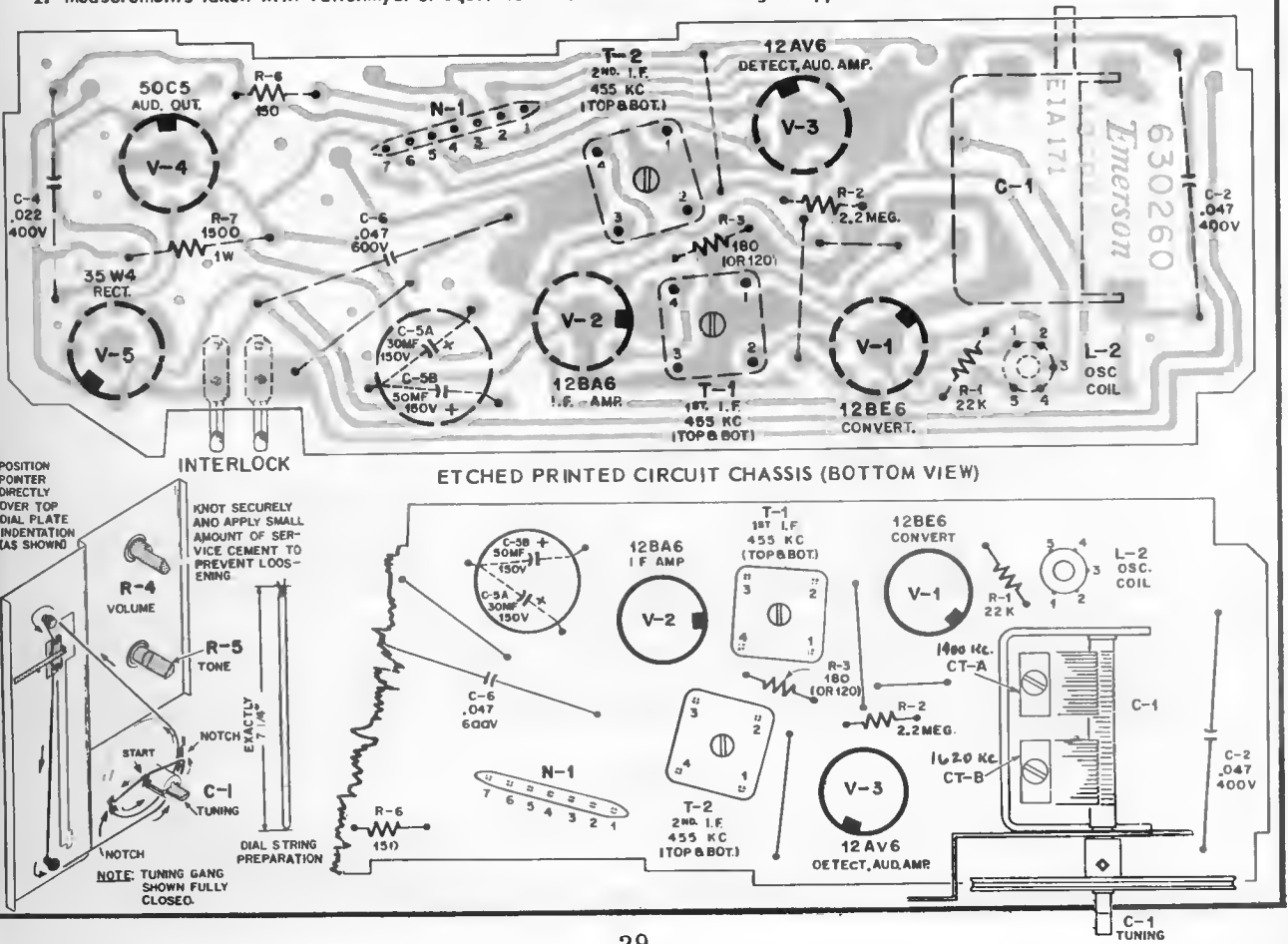

EMERSON Model G-1707

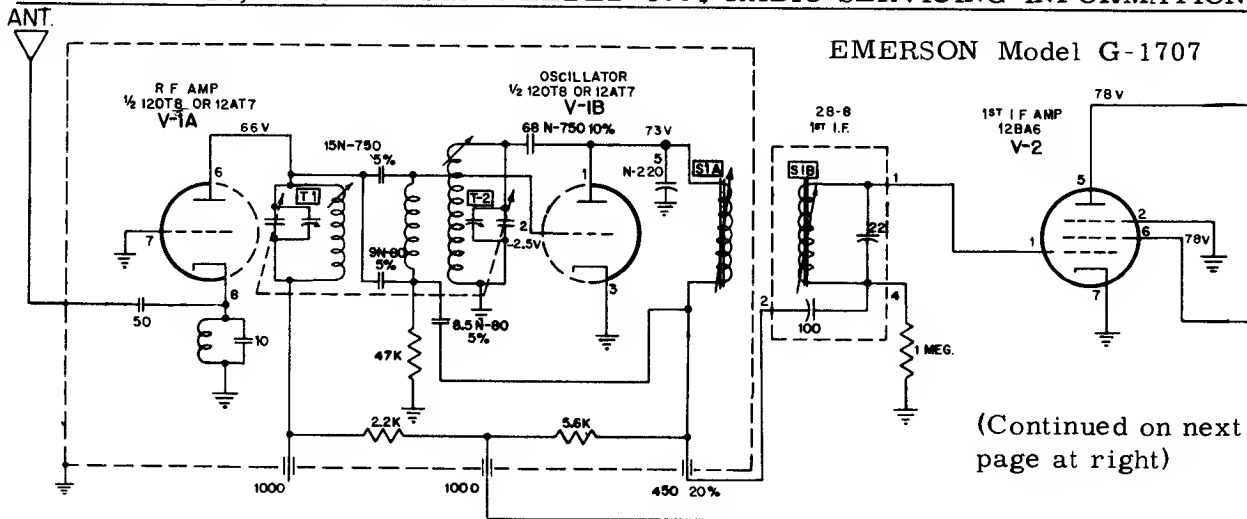

(Continued on next page at right)

ALIGNMENT INSTRUCTIONS

- 1) Allow chassis and equipment to be used at least 15 minutes for warm-up.
- 2) Maintain output of signal generator at a point no higher than required to produce a usable reading and use only insulated alignment tools for adjusting.
- 3) Use an isolation transformer between the chassis and the AC line, if available. If no isolation transformer is to be used, insert a .1 mfd. capacitor in series with the signal generator output cable to prevent shock and to protect the equipment.

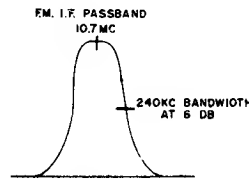

FIG. 1

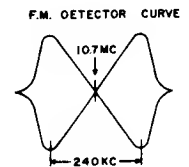

FIG. 2

FM IF ALIGNMENT USING AM SIGNAL GENERATOR AND VTVM

SIGNAL GENERATOR COUPLING	SIGNAL GEN. FREQ.	RADIO DIAL SETTING	CONNECT VTVM	ADJUST	REMARKS
1. TO PIN 8 (CATHODE) OF 12DT8 THROUGH A 50 MMF (REMOTE ANT. HANK)	10.7MC (UNMOD.)	POINT OF NON-INTERFERENCE	DC PROBE TO POINT COMMON TO CHASSIS	T3, S2 S1B S1A.	ADJUST FOR MAXIMUM DEFLECTION.
2. " " " " " "	" " " " " "	" " " " " "	DC PROBE TO POINT COMMON TO POINT	T4	ADJUST FOR ZERO READING. A POSITIVE AND NEGATIVE READING WILL BE OBTAINED ON EITHER SIDE OF THE CORRECT SETTING. PROCEED WITH STEP 5.

FM IF ALIGNMENT USING FM SIGNAL GENERATOR AND OSCILLOSCOPE

FREQUENCY MODULATE THE IF SIGNAL WITH A 60 CYCLE SINE WAVE TO A TOTAL DEVIATION OF 450 KC. ADJUST THE OSCILLOSCOPE INTERNAL HORIZONTAL DEFLECTION VOLTAGE TO 120 CYCLES, AND SYNCHRONIZE IT WITH THE 60 CYCLE SINE WAVE.

SIGNAL GENERATOR COUPLING	SIGNAL GEN. FREQ.	RADIO DIAL SETTING	CONNECT SCOPE	ADJUST	REMARKS
3. TO PIN 8 (CATHODE) OF 12DT8 THROUGH A 50 MMF (REMOTE ANT. HANK)	10.7MC (450 KC TOTAL DEV.)	POINT OF NON-INTERFERENCE	VERT AMP TO POINT LOW SIDE TO CHASSIS	T3, S2 S1B, S1A.	DISCONNECT STABILIZING CAPACITOR 2MFD. ADJUST FOR CURVE OF MAXIMUM AMPLITUDE AND SYMMETRY SIMILAR TO FIG. 1.
4. " " " " " "	" " " " " "	" " " " " "	VERT. AMP TO POINT LOW SIDE TO POINT	T4	RECONNECT STABILIZING CAPACITOR 2MFD. ADJUST SO THAT 10.7MC OCCURS AT CENTER OF CROSSOVER LINES SIMILAR TO FIG. 2. SLIGHTLY RE-TOUCH T3 FOR MAX. AMPLITUDE AND STRAIGHTNESS OF CROSSOVER LINES. PROCEED WITH STEP 5.

FM RF ALIGNMENT

SIGNAL GENERATOR COUPLING	SIGNAL GEN. FREQ.	RADIO DIAL SETTING	CONNECT VTVM	ADJUST	REMARKS
5. TO PIN 8 (CATHODE) OF 12DT8 THROUGH A 50 MMF (REMOTE ANT. HANK)	108MC	108MC (SLUGS OUT)	DC PROBE TO POINT COMMON TO CHASSIS	T1, T2	ADJUST FOR MAXIMUM DEFLECTION.
6. " " " " " "	88MC	88MC (SLUGS IN)	" " " " " "	PADDER FLAPS	MOVE PADDER FLAPS CLOSER OR FURTHER FROM OSC. & RF COILS FOR MAX. DEFLECTION. REPEAT STEPS 5 & 6. FOR HIGHEST READING.

VOLUME R-24, MOST-OFTEN-NEEDED 1964 RADIO SERVICING INFORMATION

EMERSON RADIO Model G-1707, Continued from preceding page, at left.

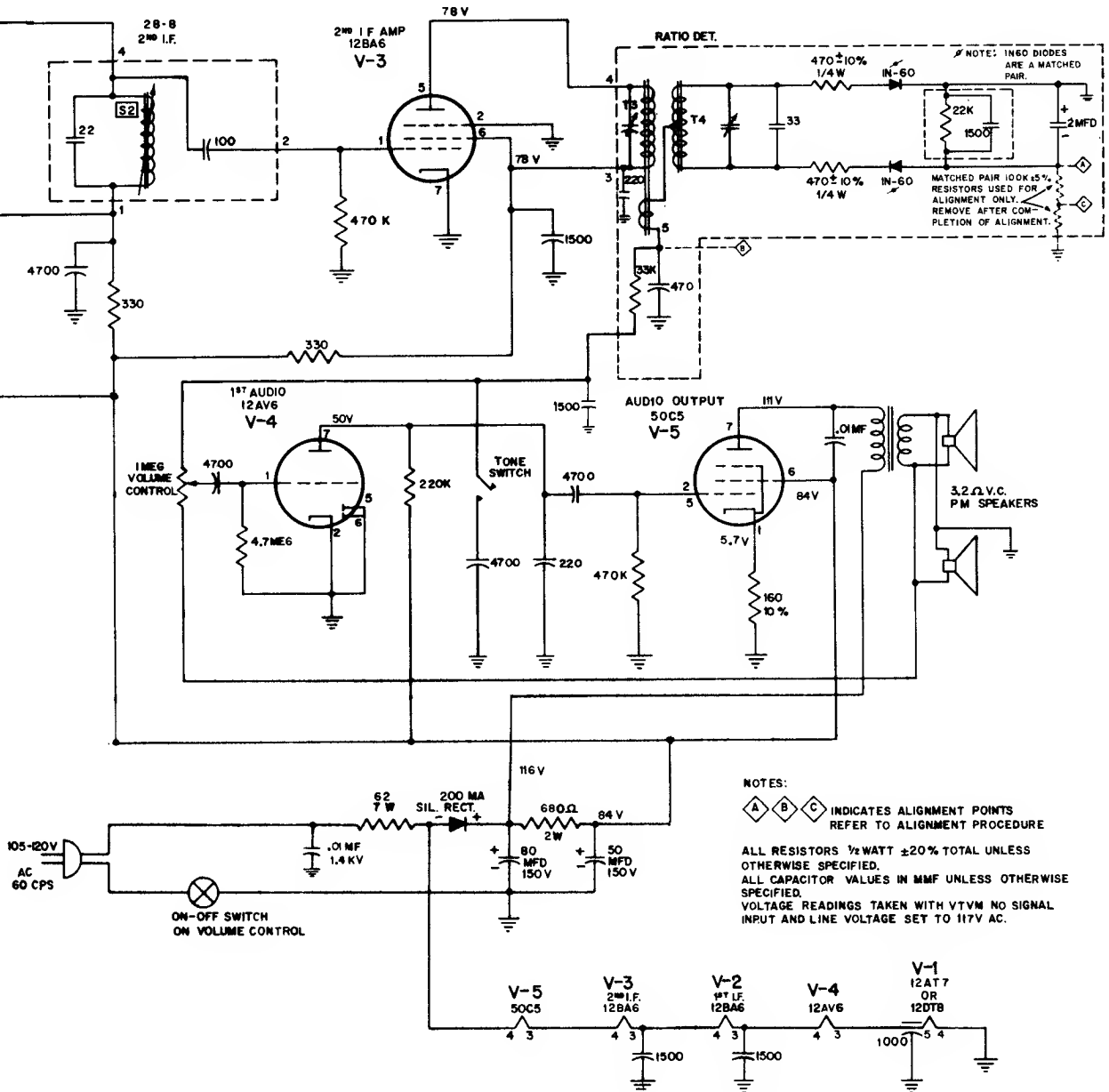

NOTES:
 A B C INDICATES ALIGNMENT POINTS REFER TO ALIGNMENT PROCEDURE
 ALL RESISTORS 1/2 WATT ±20% TOTAL UNLESS OTHERWISE SPECIFIED.
 ALL CAPACITOR VALUES IN MMF UNLESS OTHERWISE SPECIFIED.
 VOLTAGE READINGS TAKEN WITH VTVM NO SIGNAL INPUT AND LINE VOLTAGE SET TO 117V AC.

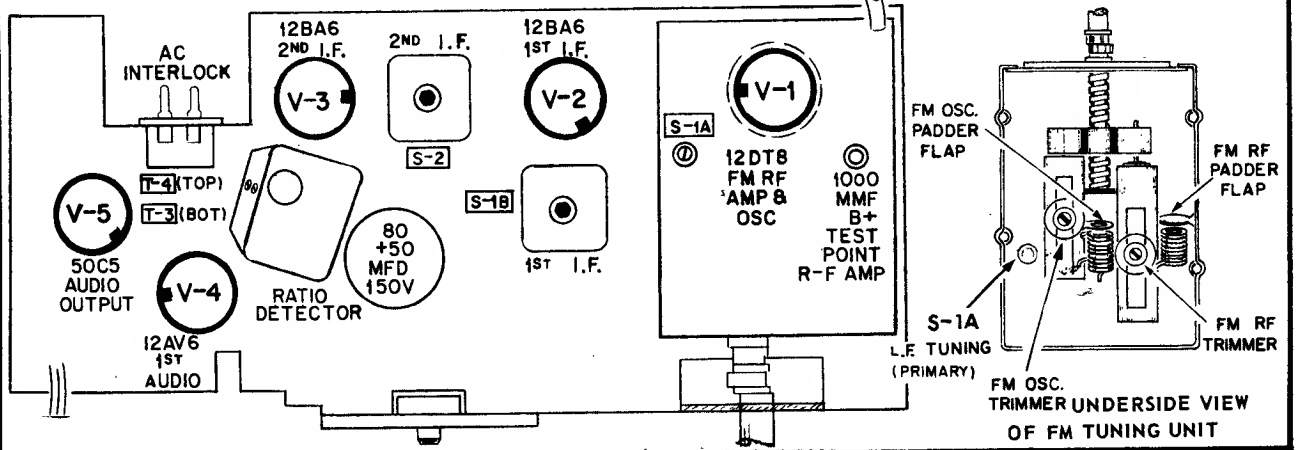

TUBE LOCATION AND ALIGNMENT POINTS

EMERSON RADIO Model G-1708, Continued on the next page at right.

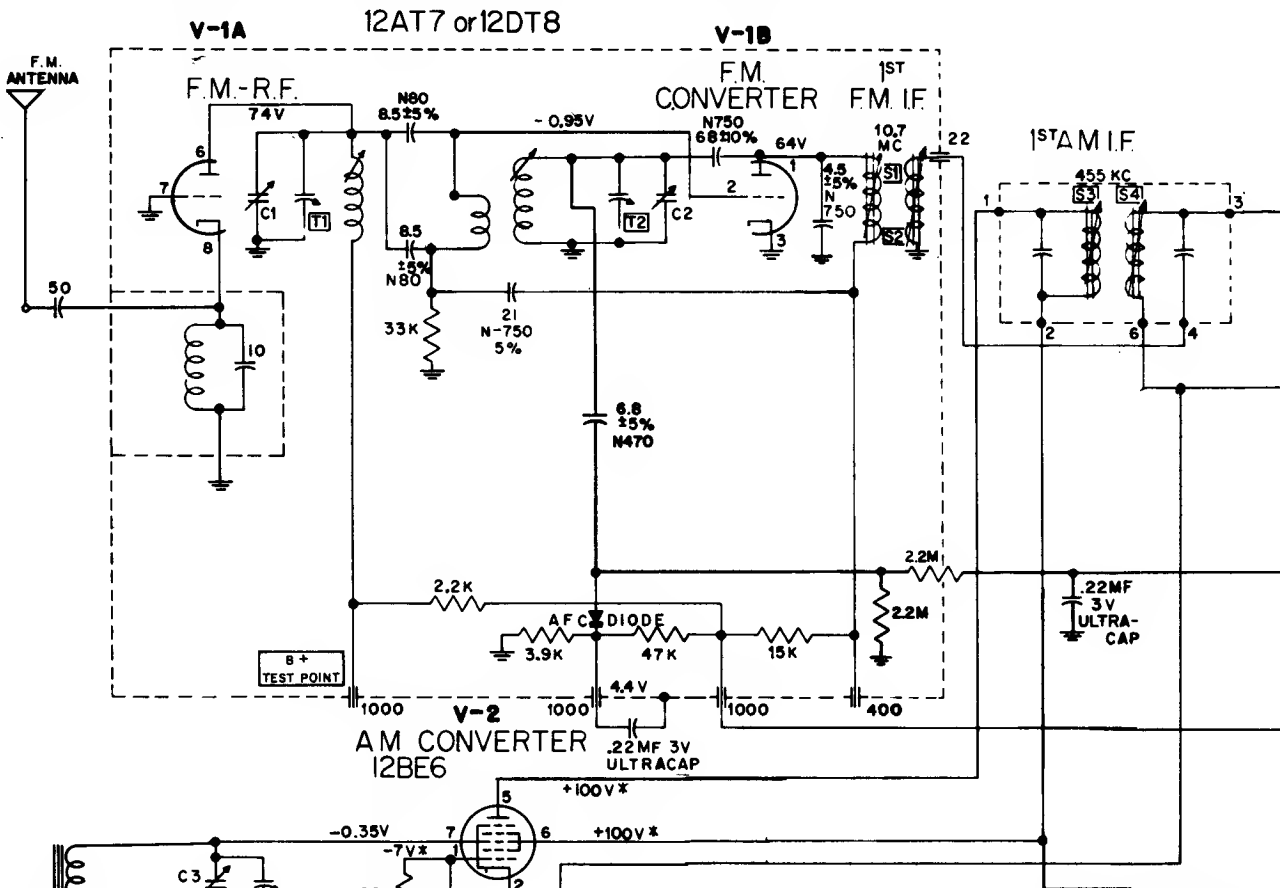

NOTES: All measurements taken between points indicated and chassis ground, unless otherwise specified.
 * Indicates measurements taken with common lead of VTVM connected to B+ 126V line (junction of silicon rectifier and 80 mfd. electrolytic capacitor).
 K denotes kilohms; M denotes megohms; N.C. denotes no connection to terminal indicated.

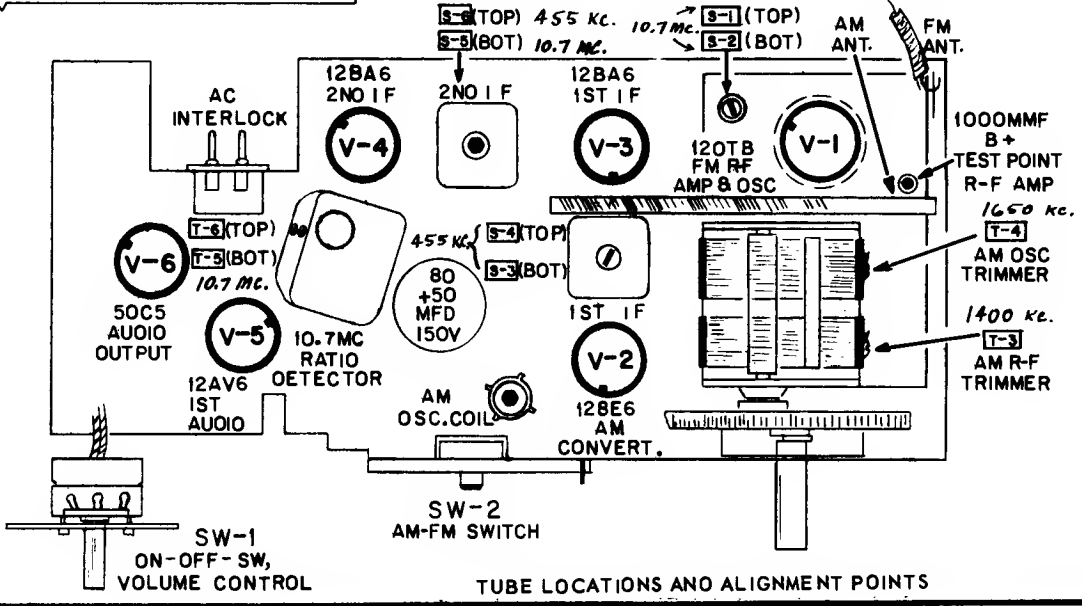

VOLUME R-24, MOST-OFTEN-NEEDED 1964 RADIO SERVICING INFORMATION

EMERSON RADIO Model G-1708, Continued from the preceding page at left.

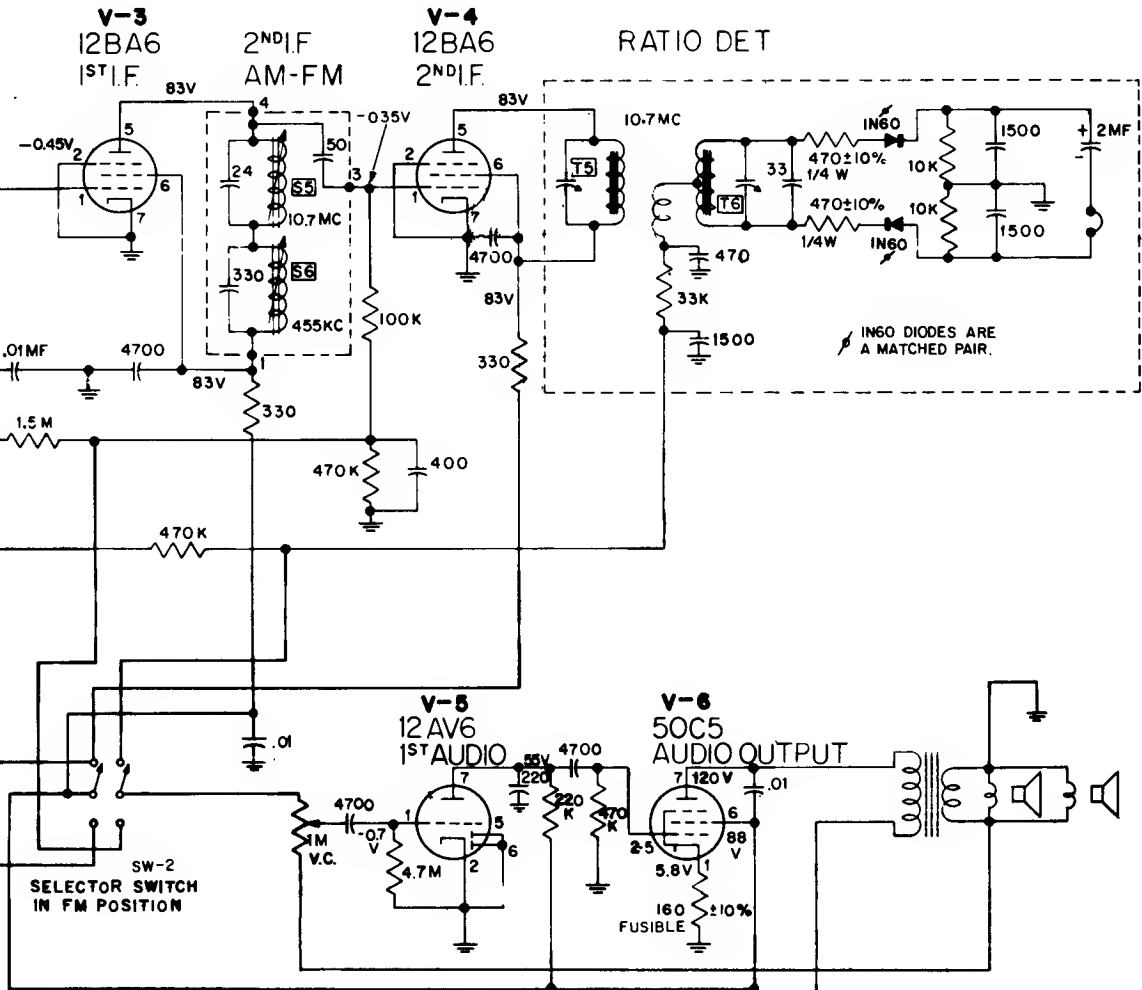

NOTES:
 C1, C2, C3, C4 GANGED
 UNLESS OTHERWISE SPECIFIED
 ALL RESISTOR VALUES IN OHMS, 1/2W ± 20%
 K=1000Ω M=MEGΩ
 ALL CAPACITOR VALUES IN MMF
 USE V.T.V.M. FOR VOLTAGE MEASUREMENTS
 BAND SWITCH ON FM POSITION, NO SIGNAL,
 LINE VOLTAGE 117 VOLTS RMS 60 ~
 ALL VOLTAGES MEASURED WITH RESPECT
 TO CHASSIS GROUND
 *INDICATES READINGS TAKEN IN A M POSITION

RESISTANCE READINGS CHART, MODEL G-1708

Symbol No.	Tube Type	SW-2 Position	PIN 1	PIN 2	PIN 3	PIN 4	PIN 5	PIN 6	PIN 7	PIN 8	PIN 9
V-1	12DT8	FM	* 16K	33K	0	0	10	* 3.1K	0	0	N. C.
V-2	12BE6	AM	22K	0.4	20	32	*910	*900	1	-	-
V-3	12BA6	AM or FM	1.6M	0	32	44	* 1.2K	* 1.2K	0	-	-
V-4	12BA6	FM	470K	0	44	56	* 1.2K	* 1.2K	0	-	-
V-5	12AV6	AM or FM	4.7M	0	20	10	0	0	* 220K	-	-
V-6	50C5	AM or FM	160	470K	56	100	470K	* 900	* 150	-	-

EMERSON Model P-1913, Tuner Chassis 120640

(See next page, adjacent at right, for data on amplifier unit used.)

Emerson Model P-1913 is a combined radio and phonograph combination designed for playing of both stereophonically and monophonically recorded discs, as well as reception of standard AM radio programs and FM programs broadcast either monophonically or in the stereo mode. It is equipped with a high-fidelity, dual-channel 20 watt stereo amplifier and a separate FM/AM tuning chassis with built-in stereo multiplex circuits and FM stereo indicator lamp. The separate phono pre-amplifier chassis used in this model, in conjunction with the four-speed stereo record changer employed, provides high-quality reproduction of all types of records, including the older 78 RPM variety. Model P-1913 is equipped with a total of six self-contained loudspeakers, one wide-range speaker and two high-frequency tweeters for each of the stereo channels.

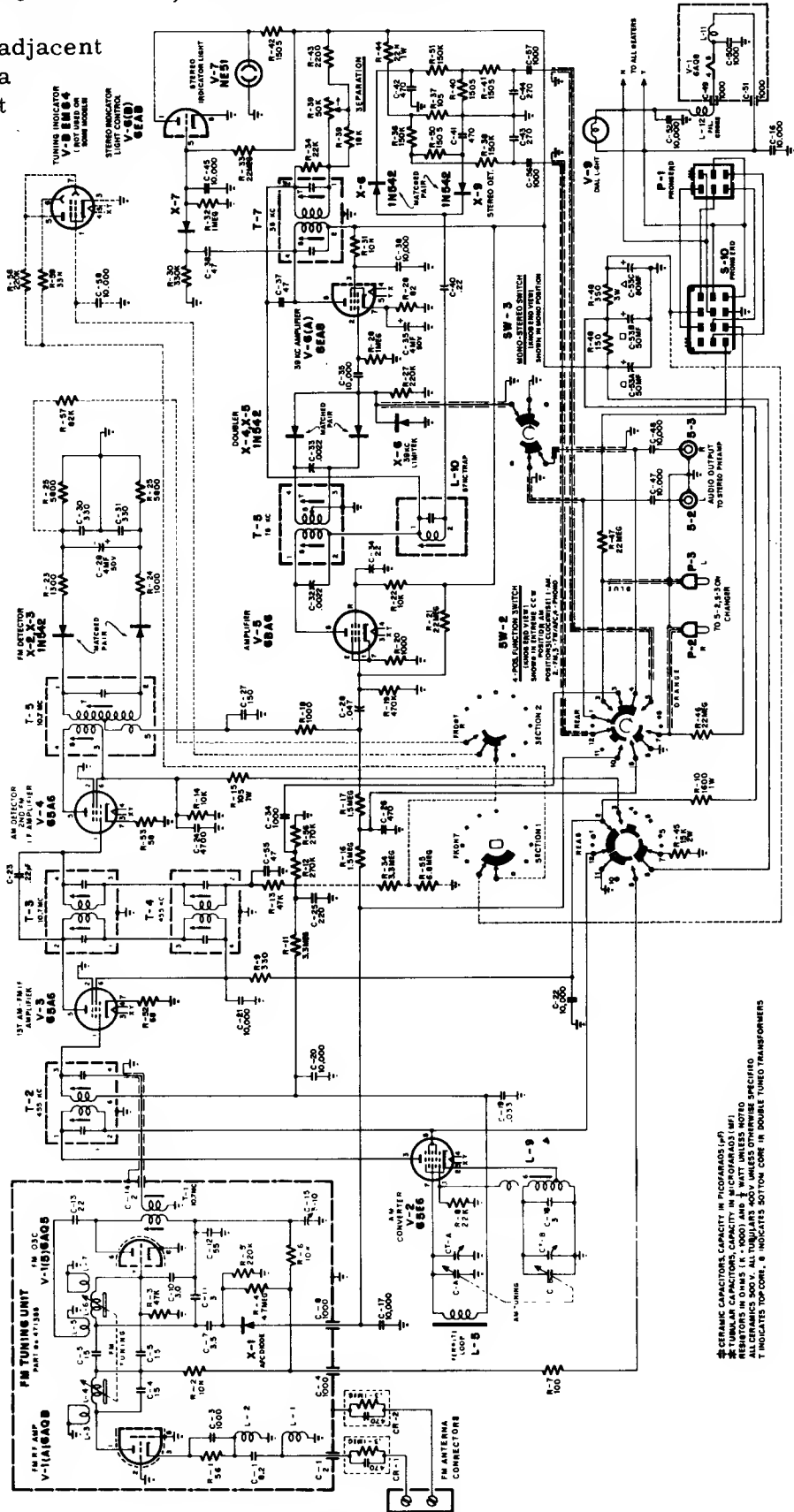

* CERAMIC CAPACITORS IN PICTORIALS (P)
 ** RESISTORS IN OHMS (Ω)
 † RESISTORS IN OHMS (Ω), 1000 (K) AND 10,000 (M) WATT UNLESS NOTED
 ALL DIMENSIONS IN INCHES UNLESS OTHERWISE SPECIFIED
 ‡ DIMENSIONS IN MILLIMETERS UNLESS OTHERWISE SPECIFIED
 † INDICATES TOP CORNER IN DOUBLE TUNED TRANSFORMERS

AM-FM STEREO TUNER CHASSIS No. 120640

EMERSON Model P-1913, Amplifier Chassis 120639 and 120647
(Continued from preceding page)

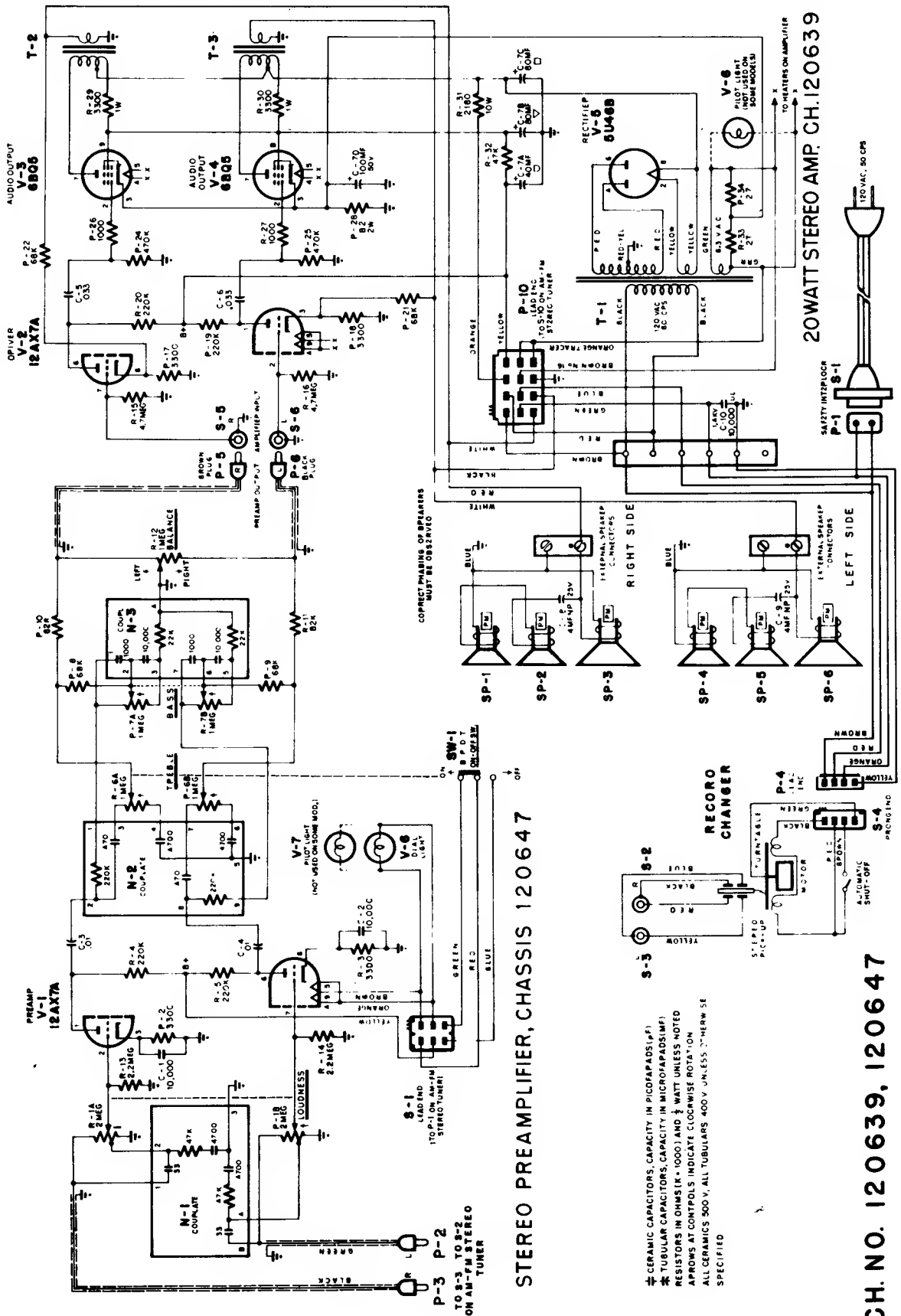

CH. NO. 120639, 120647

EMERSON Model P-1914
Chassis 120649
(Continued on next page)

MONAURAL AND STEREO AMPLIFIER BOARD

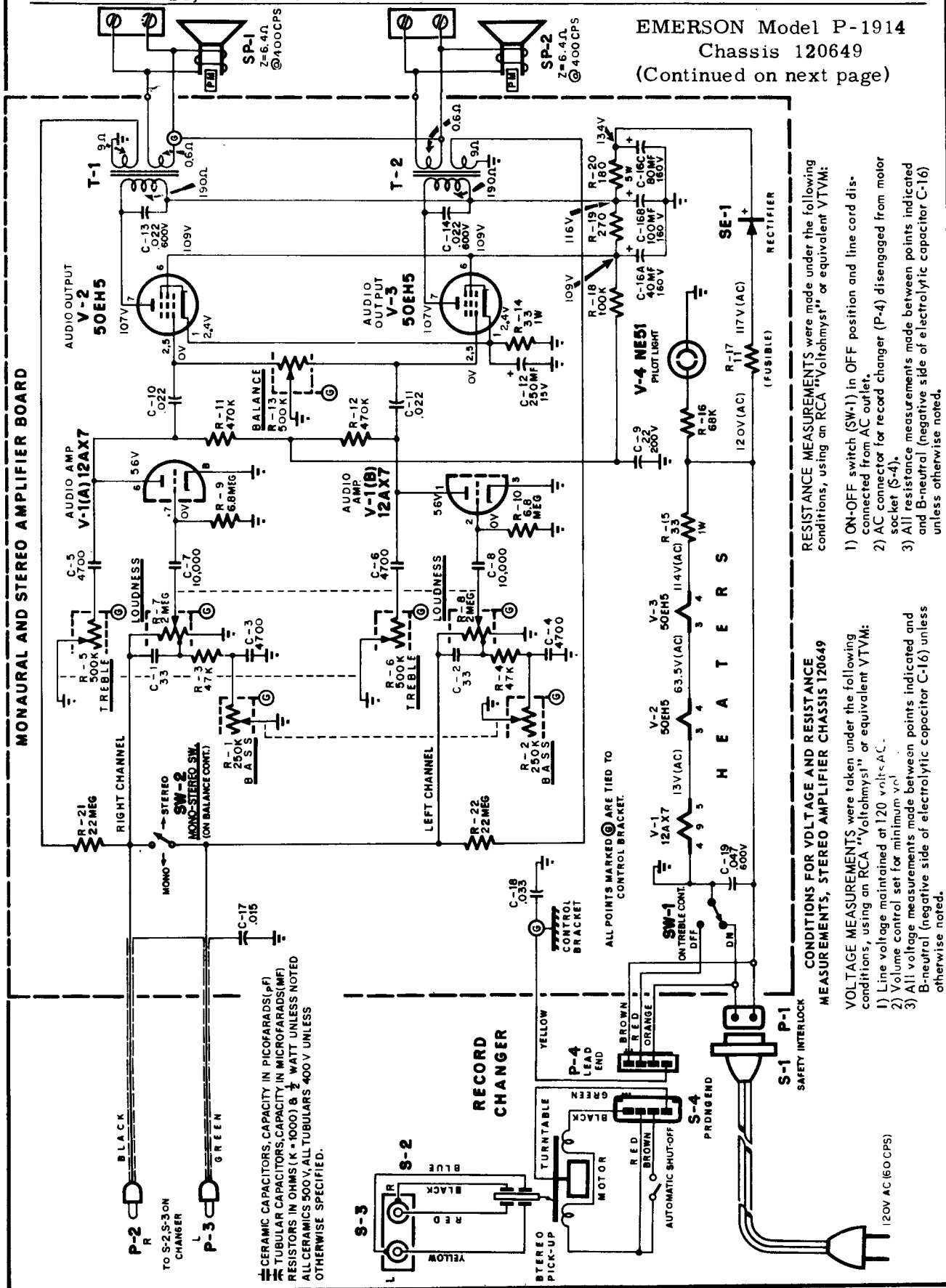

CAPACITY IN PICOFARADS (PF)
 CAPACITY IN MICROFARADS (MF)
 IN OHMS (K = 1000) & $\frac{1}{2}$ WATT UNLESS NOTED
 ALL CERAMICS 500V, ALL TUBULARS 400V UNLESS OTHERWISE SPECIFIED.

ALL POINTS MARKED ARE TIED TO CONTROL BRACKET.

CONDITIONS FOR VOLTAGE AND RESISTANCE MEASUREMENTS, STEREO AMPLIFIER CHASSIS 120649

- VOLTAGE MEASUREMENTS were taken under the following conditions, using an RCA "Voltohmyst" or equivalent VTVM:
- 1) Line voltage maintained at 120 volts A.C.
 - 2) Volume control set for minimum vol.
 - 3) All voltage measurements made between points indicated and B-neutral (negative side of electrolytic capacitor C-16) unless otherwise noted.

RESISTANCE MEASUREMENTS were made under the following conditions, using an RCA "Voltohmyst" or equivalent VTVM:

- 1) ON-OFF switch (SW-1) in OFF position and line cord disconnected from AC outlet.
- 2) AC connector for record changer (P-4) disengaged from motor socket (S-4).
- 3) All resistance measurements made between points indicated and B-neutral (negative side of electrolytic capacitor C-16) unless otherwise noted.

VOLUME R-24, MOST-OFTEN-NEEDED 1964 RADIO SERVICING INFORMATION

EMERSON Model P-1914, Chassis 120649, Continued from preceding page

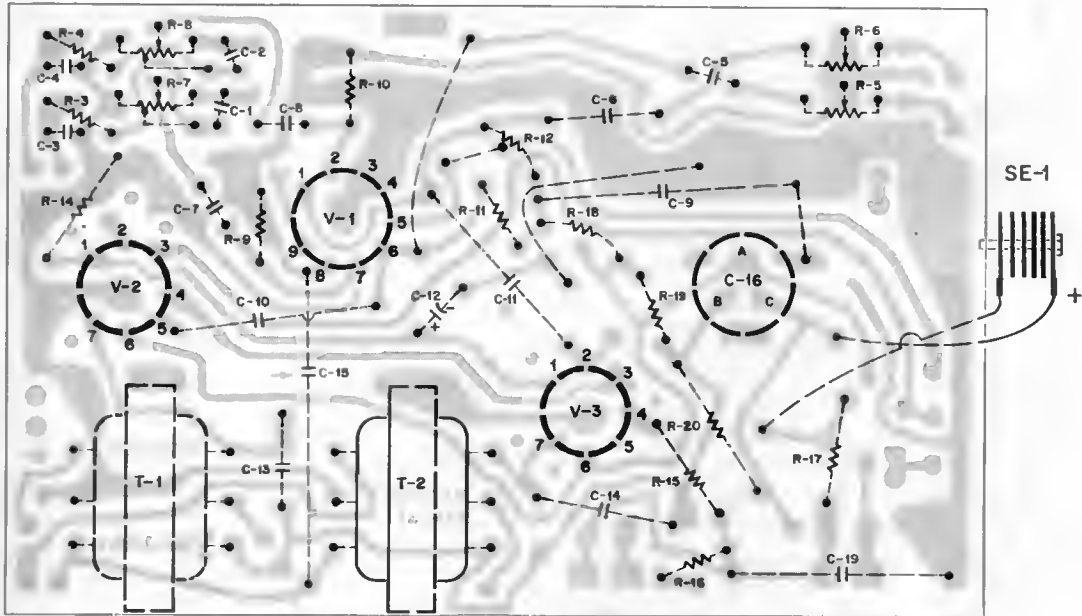

ETCHED PRINTED CIRCUIT CHASSIS (Bottom View)

RESISTANCE READINGS, STEREO AMPLIFIER CHASSIS 120649

SYM.	TUBE TYPE	PIN 1	PIN 2	PIN 3	PIN 4	PIN 5	PIN 6	PIN 7	PIN 8	PIN 9
V-1	12AX7	*570K	6.8 M	0	0	18	*570K	6.8 M	0	9
V-2	50EH5	33	30 to .5 M	18	64	30 to .5 M	*450	*370	-	-
V-3	50EH5	33	30 to .5 M	64	112	30 to .5 M	*450	*370	-	-

* MEASURED WITH COMMON LEAD OF METER CONNECTED TO POSITIVE SIDE OF SELENIUM RECTIFIER SE-1.

EMERSON Model P-1926, Chassis 120693

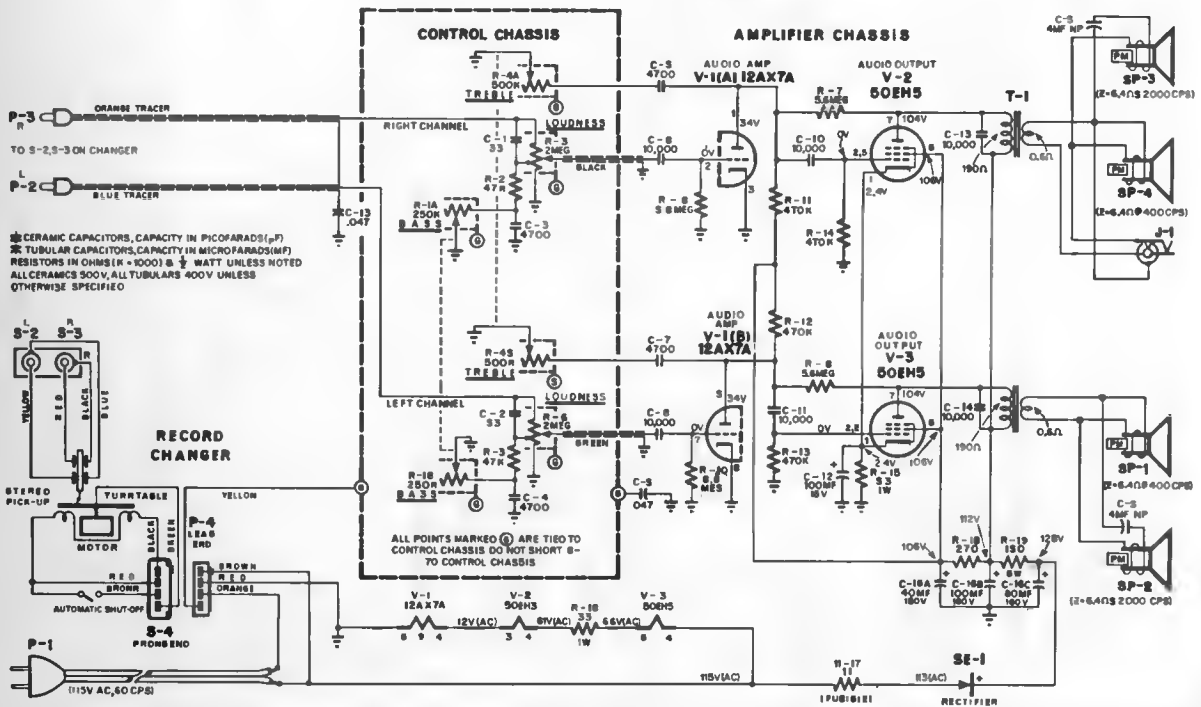

EMERSON Models P-1936, P-1937, using Amplifier Chassis 120637

(See next page at right for diagram of tuner)

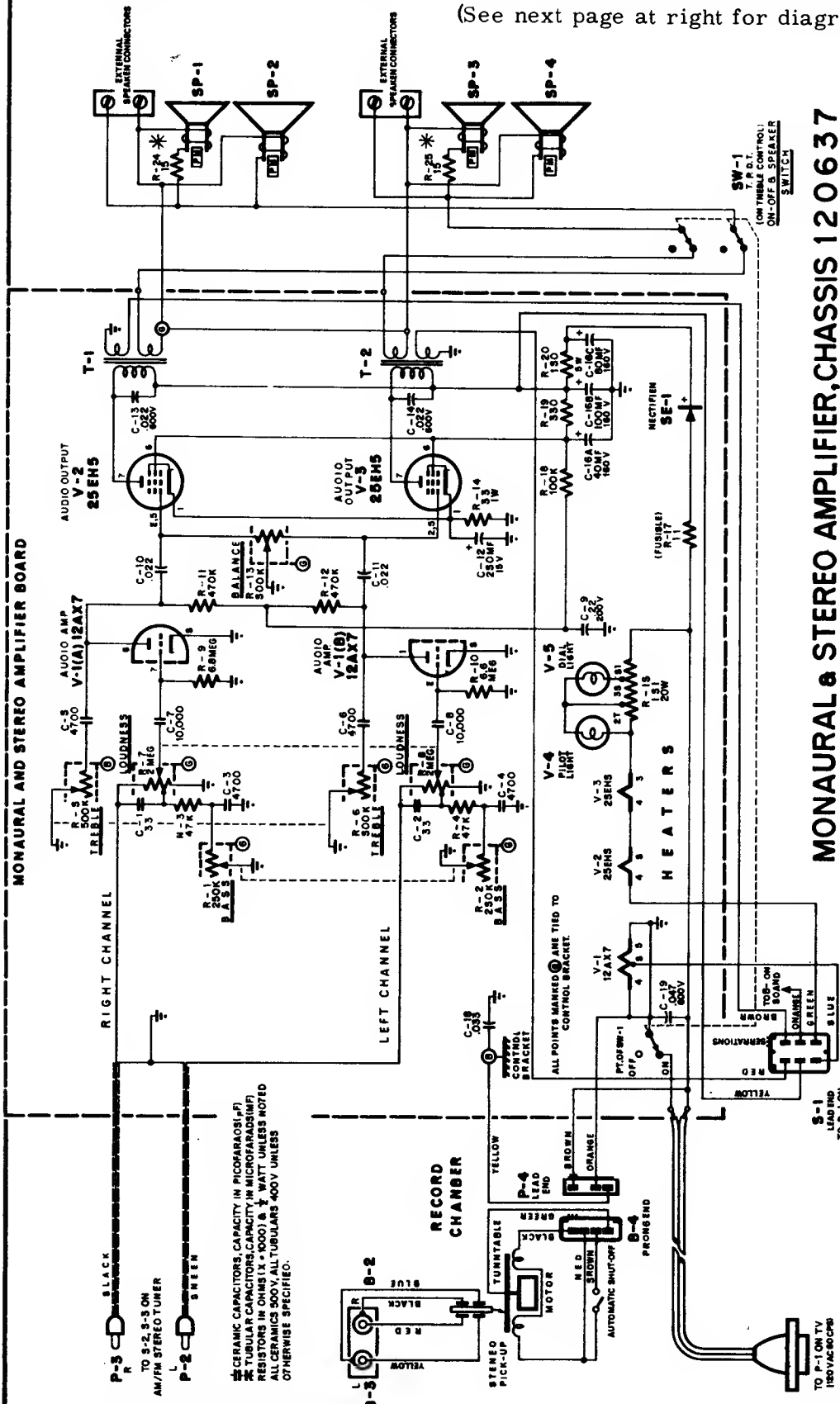

MONAURAL & STEREO AMPLIFIER, CHASSIS 120637

NOTE 1 - Proper phasing of loudspeakers must be observed when making replacements.

(*) NOTE 2 - R-24 and R-25 used in Model P-1936 only. Model P-1937 utilizes two 4 mfd. non-polarized capacitors (Pt. #925391) in place of these resistors to provide high-frequency cross-over.

EMERSON Models P-1936, P-1937, using Amplifier Chassis 120637

(See next page at right for diagram of tuner used)

EMERSON Tuner Chassis 120638
 used in Models P-1915,
 P-1936, and P-1937.

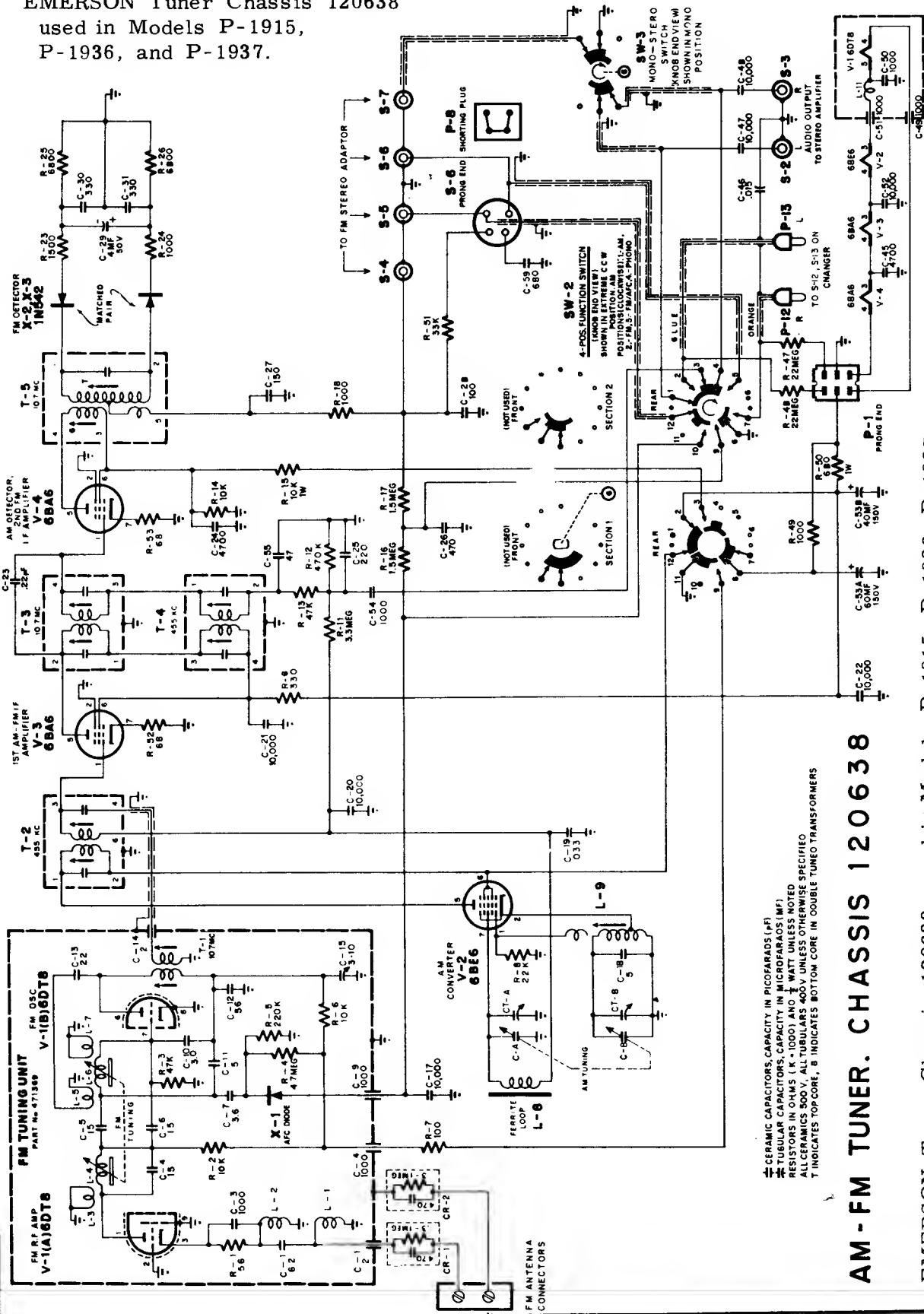

■ CERAMIC CAPACITORS, CAPACITY IN PICOFARADS (PF)
 ▬ TUBULAR CAPACITORS, CAPACITY IN MICROFARADS (MF)
 ▬ RESISTORS IN OHMS (K = 1000) AND 1/2 WATT UNLESS NOTED
 ALL CERAMICS 500V, ALL TUBULARS 400V UNLESS OTHERWISE SPECIFIED
 T INDICATES TOP CORE, B INDICATES BOTTOM CORE IN DOUBLE TUNED TRANSFORMERS

AM - FM TUNER. CHASSIS 120638

EMERSON Tuner Chassis 120638, used in Models P-1915, P-1936, P-1937

EMERSON Amplifier Chassis 120646
used in Model P-1915

(For Tuner Chassis 120638 used in this model, see preceding page.)

CHASSIS No. 120646

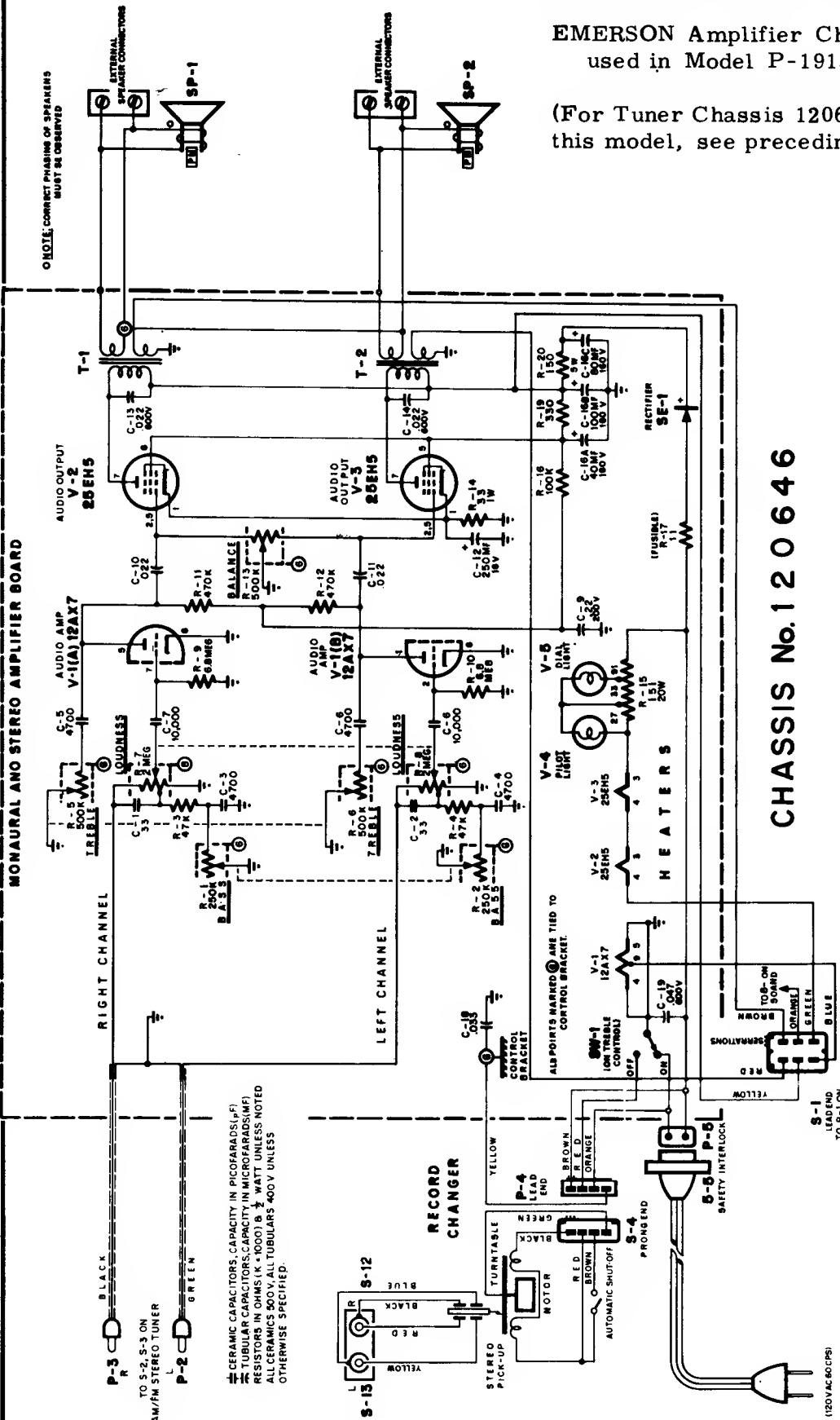

Emerson Model P-1915 is a combination FM-AM radio and stereophonic phonograph equipped with a four-speed automatic intermix record changer, complete with an automatic 45 RPM spindle adaptor. Two chassis are utilized; one for audio amplification and the other for reception of both AM and FM programs transmitted in the standard broadcast bands. Model P-1915 incorporates the Emerson "Power-Monitor" feature which, if desired, may be set to turn off both the stereo amplifier and the record changer after the last record has been played, thereby turning the unit completely off.

⊞ CERAMIC CAPACITORS, CAPACITY IN PICOFARADS (P)
⊞ TUBULAR CAPACITORS, CAPACITY IN MICROFARADS (M)
⊞ RESISTORS IN OHMS (K = 1000) Ω WATT UNLESS NOTED
⊞ ALL CERAMICS 500V, ALL TUBULARS 400V UNLESS OTHERWISE SPECIFIED.

VOLUME R-24, MOST-OFTEN-NEEDED 1964 RADIO SERVICING INFORMATION

EMERSON Models G-1710,,G-1711, Chassis 120686, 120701

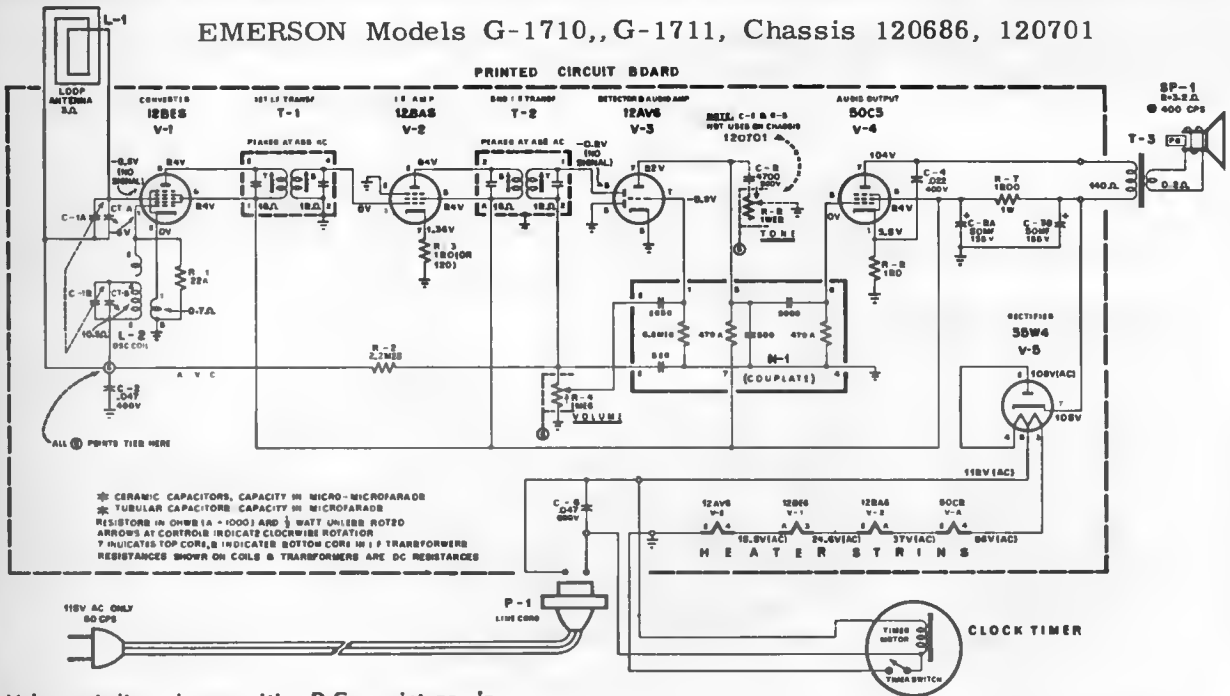

Voltagcs indicated are positive D.C., resistance in ohms unless otherwise indicated. Measurements taken with Voltahmster or equivalent VTVM. All measurement taken between points indicated ond B minus (low side of volume control).

Voltage readings indicated on schematic were taken with: (A) Line voltage set at 115 volts AC, (B) Volume control set for minimum volume, (C) Tuning capacitor fully closed.

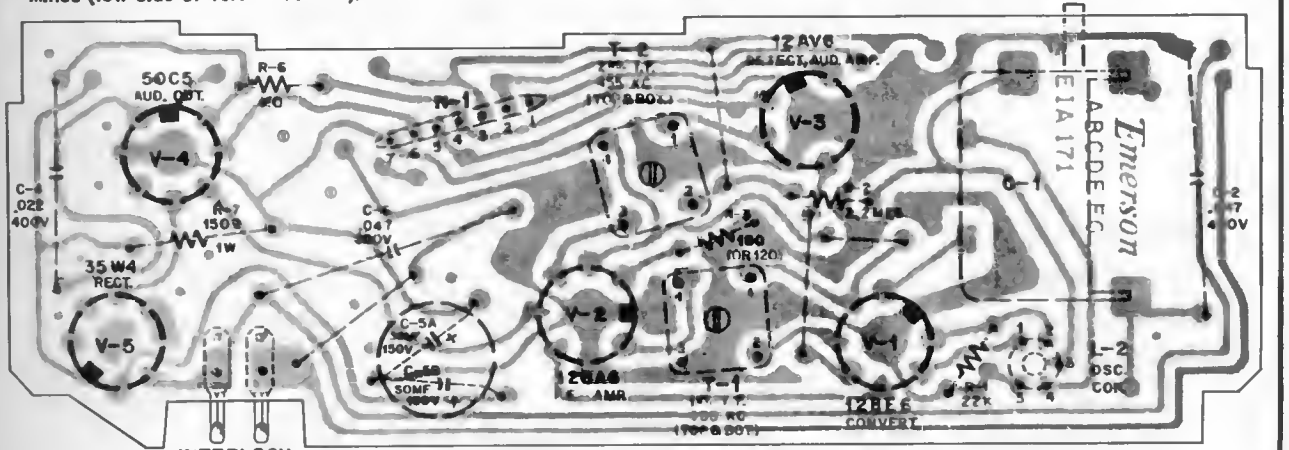

ETCHED PRINTED CIRCUIT CHASSIS (BOTTOM VIEW)

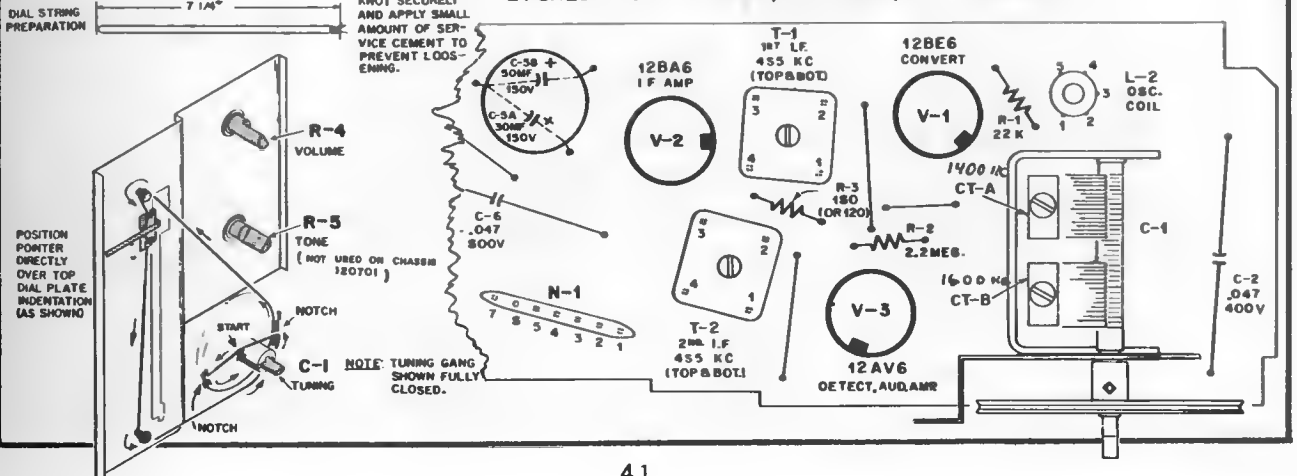

VOLUME R-24, MOST-OFTEN-NEEDED 1964 RADIO SERVICING INFORMATION

EMERSON Models P-1919, P-1920, Chassis 120668; Model P-1920A, Chassis 120693

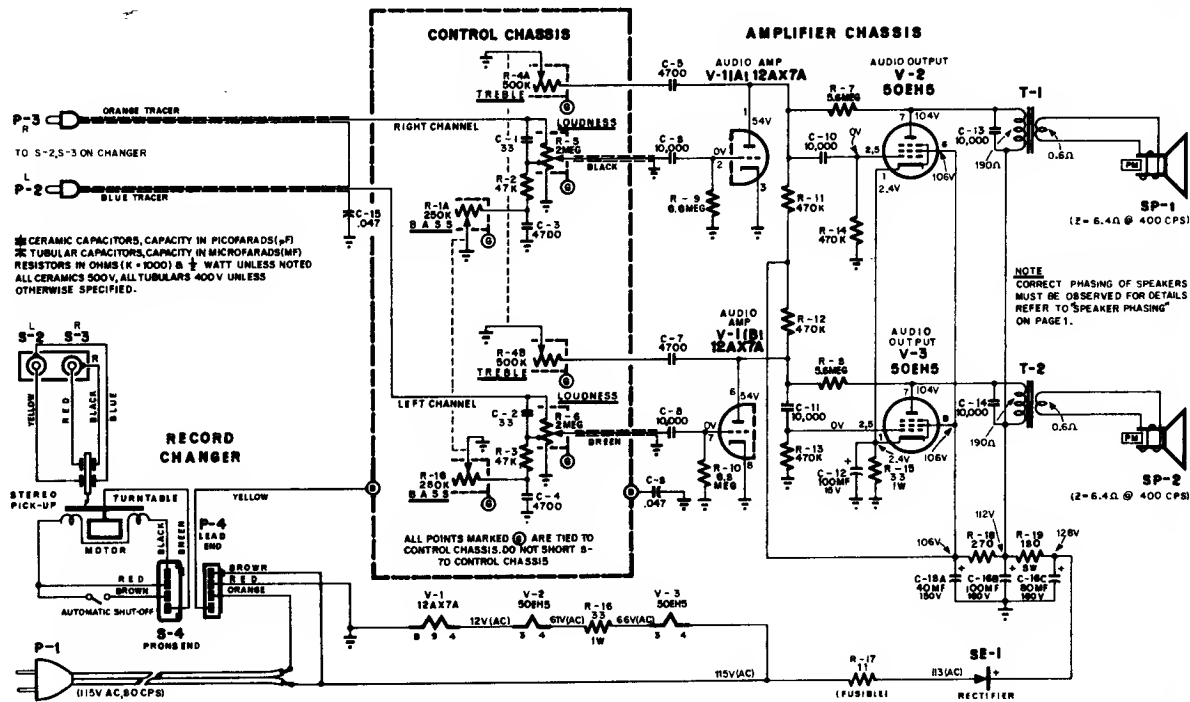

EMERSON Models P-1921, -A, Chassis 120567B

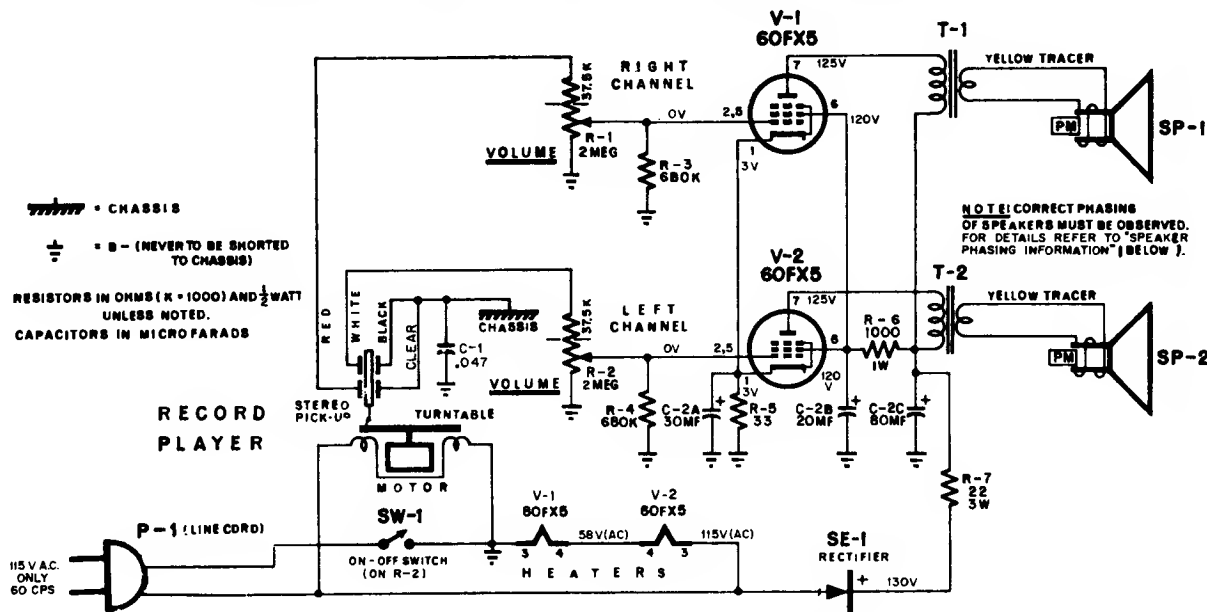

CONDITIONS FOR VOLTAGE AND RESISTANCE MEASUREMENTS

- All voltages measured with VTVM, negative lead to B- (common lead of C-2), volume control set of minimum.
- All resistance readings taken with AC cord disconnected, negative lead to B- (common lead of C-2), motor switch in "OFF" position.
- (*) Indicates varying resistance - allow 30 seconds for meter to settle.
- (**) Reading given varies with setting of volume control.
- (N.C.) Denotes no connection.

SYMBOL	TUBE TYPE	PIN 1	PIN 2	PIN 3	PIN 4	PIN 5	PIN 6	PIN 7
V-1	60 FX5	33	10Ω to 510k **	0	85	10Ω to 510k **	*1 MEG	*1 MEG
V-2	60 FX5	33	10Ω to 510k **	170	85	10Ω to 510k **	*1 MEG	*1 MEG

Emerson

MODEL: P-1923
CHASSIS: 120670

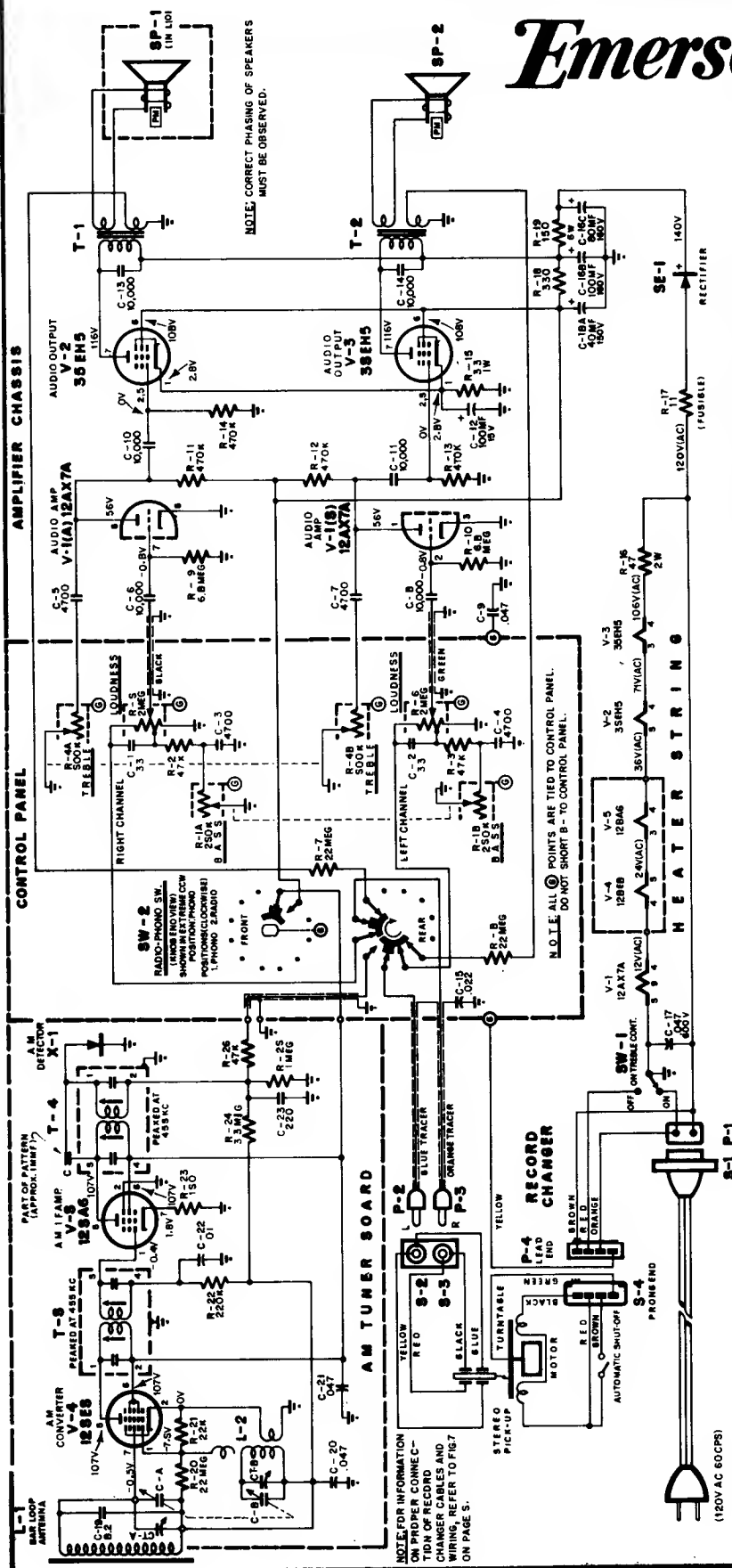

Ⓞ CERAMIC CAPACITORS, CAPACITY IN PICOFARADS (PF)
Ⓞ TUBULAR CAPACITORS, CAPACITY IN MICROFARADS (MF)
RESISTORS IN OHMS (Ω), 1000'S (K) & 10,000'S (M) UNLESS NOTED OTHERWISE SPECIFIED.

CONDITIONS FOR VOLTAGE MEASUREMENTS.

- Voltage measurements taken with:
- Line voltage maintained at 120 volts a.c.
 - Loudness control set for minimum volume.
 - Variable condenser fully closed and no signal applied.
 - Record changer in OFF position.
 - Selector switch in radio position.
- All measurements taken between points shown and B-minus (unless otherwise indicated), using an RCA Voltchymyst or equivalent VTVM.
- Normal component tolerances may cause variations of ±10% in readings obtained, which should be considered as being within limits.

ALIGNMENT PROCEDURE

Step	V. T. V. M.		ADJUST	
	SIGNAL GENERATOR	TUNING CAPACITORS		
Frequency	Connection	Range	Connection	
1.	455 KC High side to pin 7 of 12BE6 through a 1,000 mmf. capacitor, low side to B-minus (negative terminal of electrolytic capacitor C-16).	Fully closed (low end of band).	-25 Volts D.C.	T-4 Top T-4 Bottom T-3 Top T-3 Bottom Adjust for maximum output in order given.
2.	1640 KC Form loop of several turns of wire and radiate signal into receiver.	Fully open (high end of band).	As above	CT-B (Osc. Trimmer)
3.	1400 KC As above.	Tune for strongest 1400 KC signal.	As above.	CT-A (R-F. Trimmer)

Gamble-Skogmo, Inc.

Coronado Model RA60-9921A

2SA101AA

2SA101AA

2SA101AA

MA-80

2SB170

2SB172

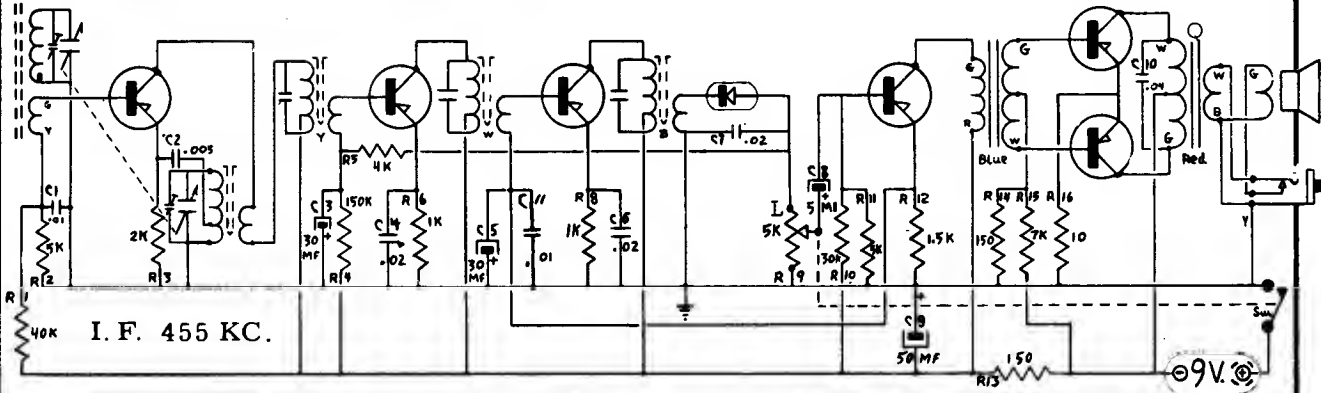

Gamble-Skogmo Coronado Model RA60-9922A

I. F. 455 KC.

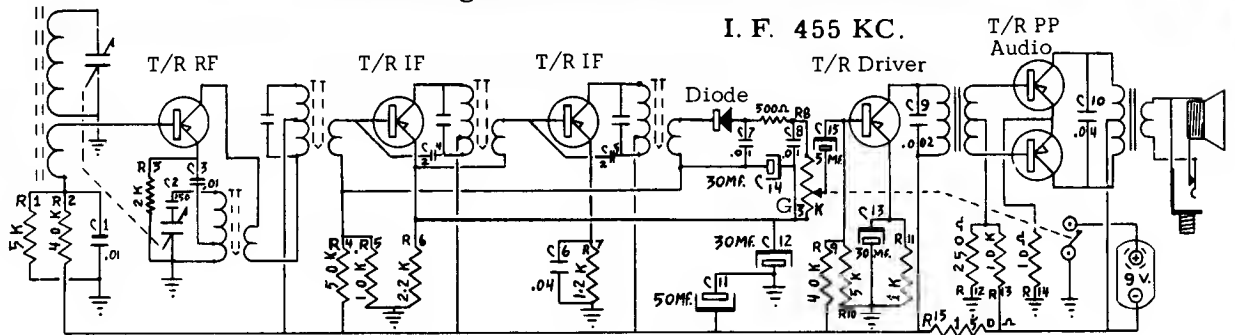

Gamble-Skogmo Coronado Model RA60-9924A

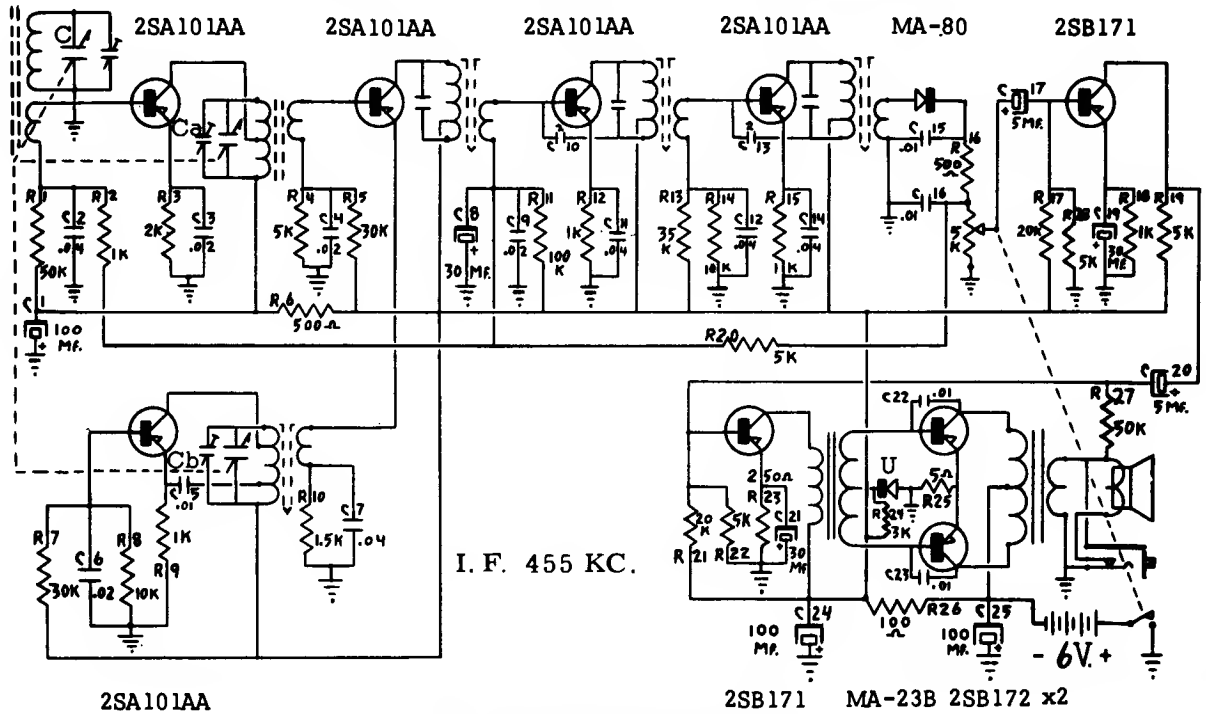

GENERAL ELECTRIC

MODELS
H220A
H221A

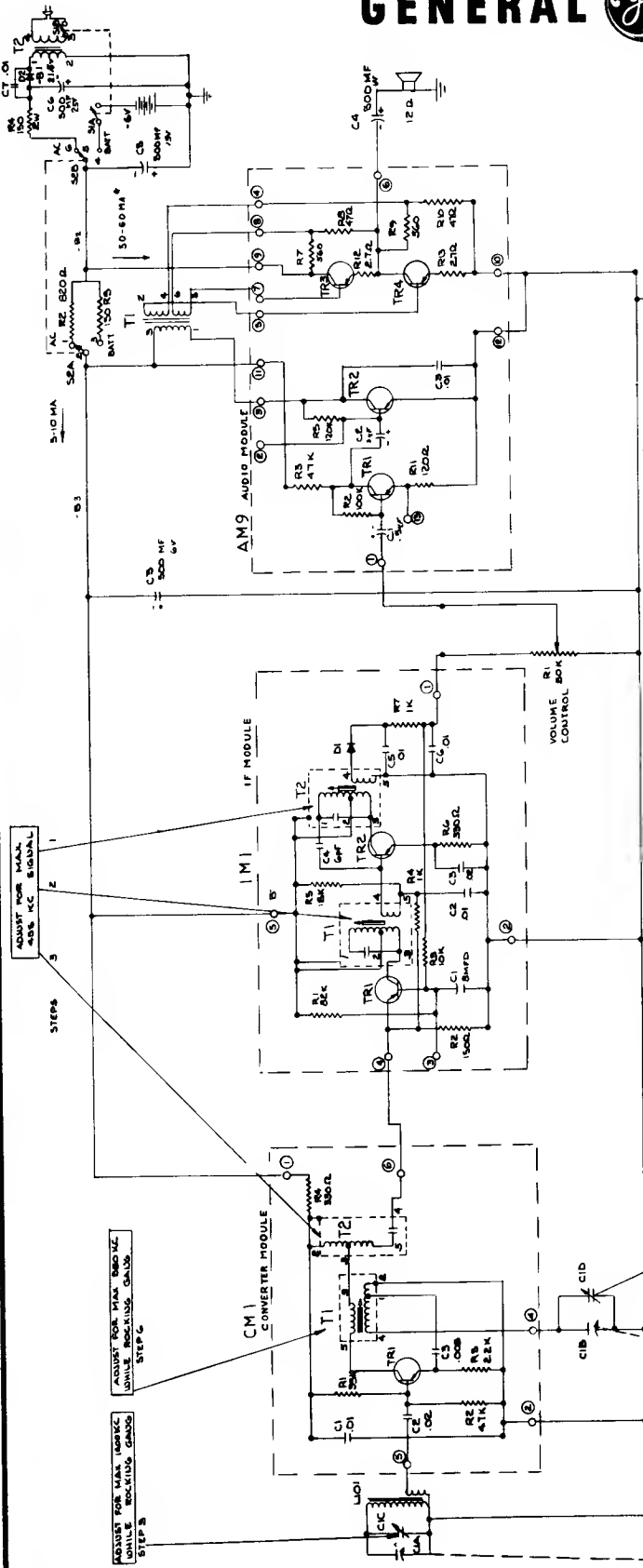

1. RELEASES ARE NEGATIVE WITH RESPECT TO GROUND UNLESS OTHERWISE NOTED.
2. CAPACITORS MORE THAN 1 MF CAPACITORS ARE 1/2 WATT, 5% RESISTORS ARE 1/4 WATT, 5%.

MODULES

This radio uses three high-reliability modules in its construction. The modules are self-contained circuit stages, each grouped on a miniature circuit board, which themselves are mounted on and soldered into the main circuit board just like any other component (transistor, capacitor, etc.).

This method of manufacture provides high reliability at an optimum cost. In fact, it allows the cost of the module to fall into the same range as tubes or transistors. This means that defects in the circuits involved in the modules need only be replaced with a good unit.

Almost always this will result in an easier, quicker, and more economical repair than would be possible if the serviceman were to try to locate and replace a defective component within a module. This radio uses such modules in the converter, I. F. and Audio stages.

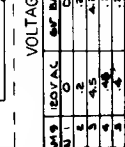
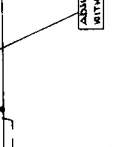
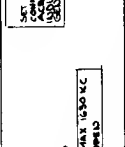
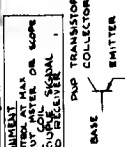
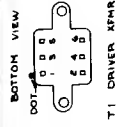

STEP	50V AC	50V BATTERY	50V BATTERY	50V BATTERY	50V BATTERY	50V BATTERY	50V BATTERY	50V BATTERY	50V BATTERY	50V BATTERY
1	0	0	0	0	0	0	0	0	0	0
2	0	0	0	0	0	0	0	0	0	0
3	0	0	0	0	0	0	0	0	0	0
4	0	0	0	0	0	0	0	0	0	0
5	0	0	0	0	0	0	0	0	0	0
6	0	0	0	0	0	0	0	0	0	0
7	0	0	0	0	0	0	0	0	0	0
8	0	0	0	0	0	0	0	0	0	0
9	0	0	0	0	0	0	0	0	0	0
10	0	0	0	0	0	0	0	0	0	0
11	0	0	0	0	0	0	0	0	0	0
12	0	0	0	0	0	0	0	0	0	0
13	0	0	0	0	0	0	0	0	0	0

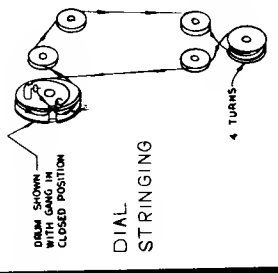

CHASSIS REMOVAL

1. Remove volume and tuning knobs.
2. Remove two Phillips-head screws from cabinet back.
3. Remove two hex-head screws inside battery compartment.
4. Remove 5 screws fastening circuit board to cabinet.
5. Carefully lift circuit board from cabinet.

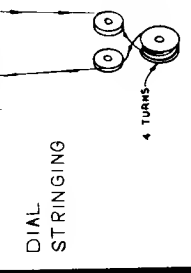
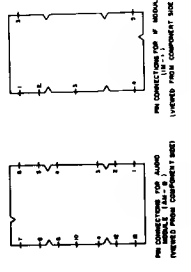



Models P895A-M, P910A-M, P911
P911A-M, P912A-M, P913A-M

(Continued on next page at right)

SCHEMATIC DIAGRAM - MODELS P910 AND P895 F, G, J, L, M

TABLE I
TABLE OF TRANSISTOR VOLTAGES

	EMITTER	BASE	COLLECTOR
TR1	.85	2.5	
TR2	.19 TO .29	.34 TO .4	2.6
TR3	.18 TO .3	.35 TO .43	2.6
TR4	.0	.2	2.6
TR5	.04	.2	3
TR6	.04	.2	3

ALIGNMENT
CONTROL AT MAX.
CONNECT VOLT METER OR SCOPE
ACROSS SPARK COIL
INDUCTIVELY COUPLER
GENERATOR TO RECEIVER

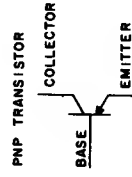

PNP TRANSISTOR
COLLECTOR
BASE
EMITTER

TRANSISTOR MTG. PATTERN
C o o E
o o B
o o I

BOTTOM VIEWS

ADJUST FOR MAX. 455 KC SIGNAL
STEP 1
STEP 2
STEP 3

ADJUST FOR MAX. 580 KC
WHILE ROCKING GANG
STEP 6

ADJUST FOR MAX. 1400 KC
WHILE ROCKING GANG
STEP 5

ADJUST FOR MAX. 1630 KC
WITH GANG OPEN
STEP 4

NOTES:
1. UNLESS OTHERWISE NOTED
CAP. MORE THAN 1 = MMF
CAP. LESS THAN 1 = MF
RES. ARE 1/2 WATT K=1000
4. * SEE TABLE 2.

2. VOLTAGES ARE NEGATIVE WITH RESPECT TO GRD
UNDER NO SIGNAL CONDITIONS & VOL. CONTROL MIN.

3. REPLACE TRANSISTORS WITH TYPES SHOWN
IN TABLE 2.

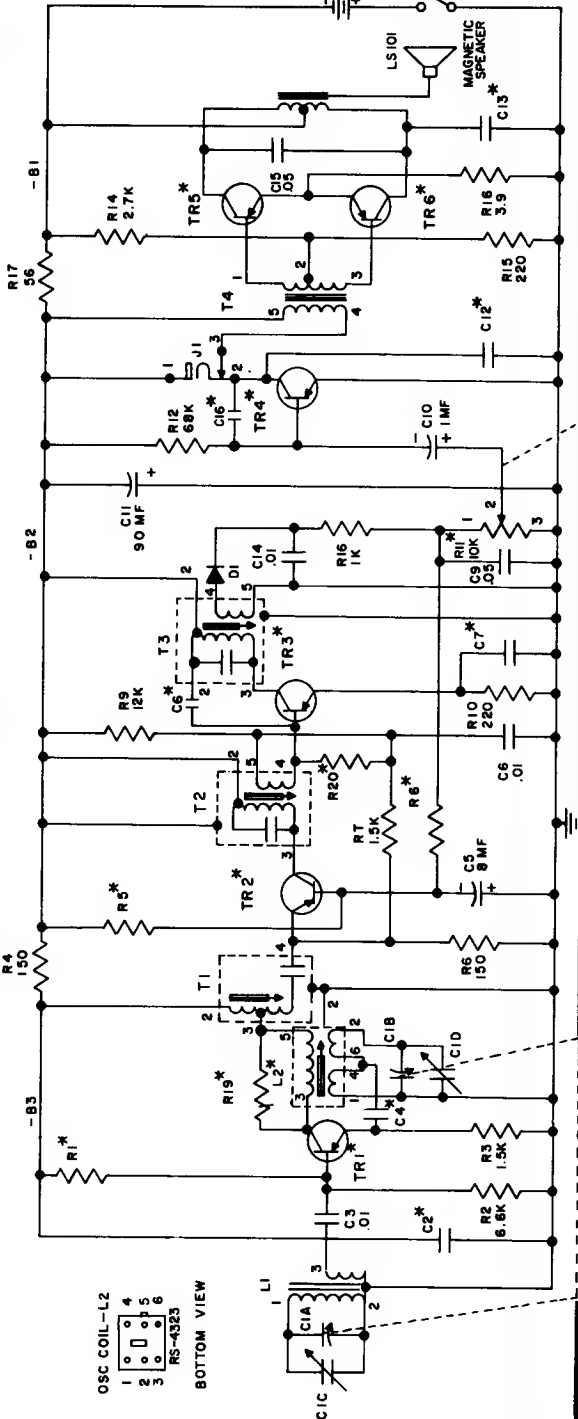
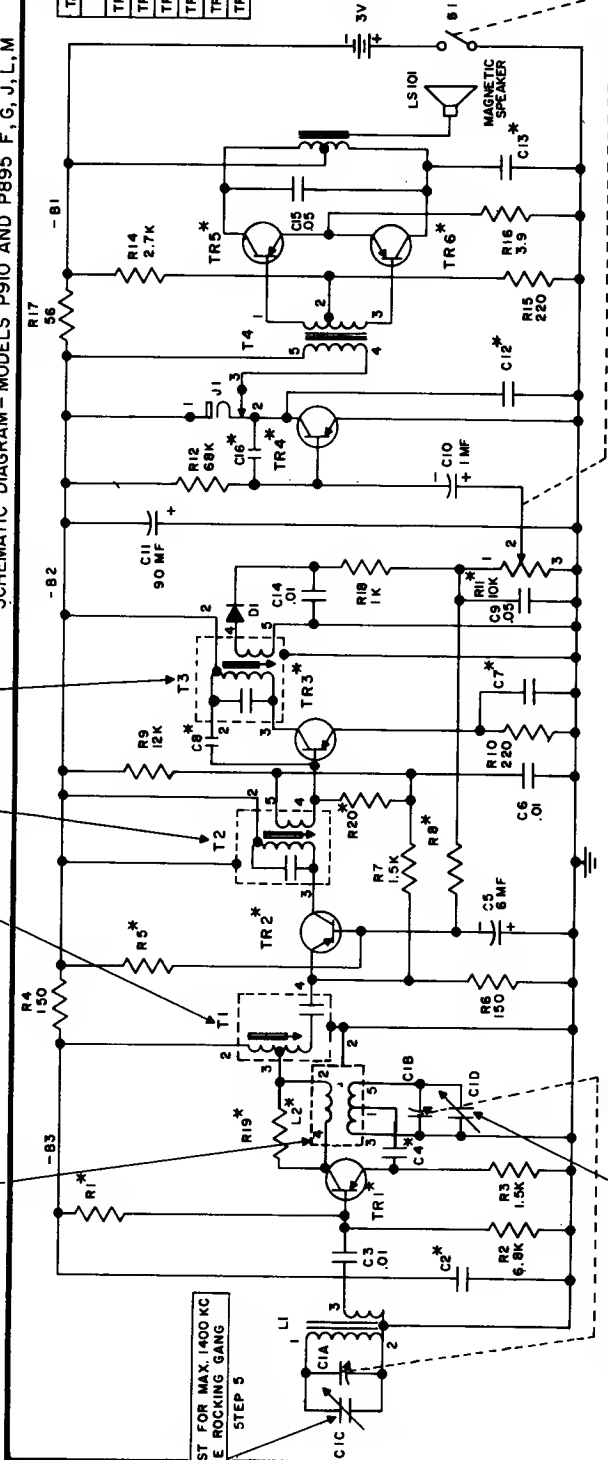
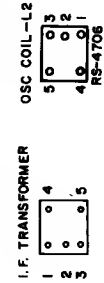

SCHEMATIC DIAGRAM - MODELS P910 AND P895 A, B, C, D, E, H, K

VOLUME R-24, MOST-OFTEN-NEEDED 1964 RADIO SERVICING INFORMATION

GENERAL ELECTRIC

Models P895A-M, P910A-M, P911A-M, P912A-M, P913A-M

(Continued from preceding page at left)

* TABLE 2 - The following components may vary in value or physical characteristics in different set versions of models P910 or P895. The proper component values or part catalog numbers for all component variables are listed under the appropriate columns.

Set Version	TRANSISTORS					RESISTORS						CAPACITORS			
	TR1	TR2	TR3	TR4	TR5 & TR6	R1	R19	R5	R20	R8	R11 (VC)	C2	C4	C7	C8
A ₁	RS-3857	RS-3862	RS-3863	RS-5504	RS-5704 or RS-5710	12K	8.2K	27K	3.3K	8.2K	RS-4326	.01	.005 or .01	.05	None
A ₂	RS-3868	RS-3862	RS-3863	RS-5504	↓	18K	5.6K	27K	3.3K	8.2K	RS-4326	.01 or .005	.005 or .01	.05	None
B ₁	RS-3868	RS-3862	RS-3863	RS-5504	↓	18K	5.6K	27K	3.3K	8.2K	RS-4707	↓	↓	.05	None
B ₂	RS-3857	RS-3862	RS-3863	RS-5504	↓	12K	8.2K	27K	3.3K	8.2K	RS-4707	.01	↓	.05	None
C ₁	RS-3857	RS-3862	RS-3863	RS-5504	↓	18K	5.6K	27K	3.3K	8.2K	RS-4326	.01 or .005	↓	.05	None
C ₂	RS-3868	RS-3862	RS-3863	RS-5504	↓	18K	5.6K	27K	3.3K	8.2K	RS-4326	↓	↓	.05	None
D ₁	RS-3868	RS-3862	RS-3863	RS-5504	↓	18K	5.6K	27K	3.3K	8.2K	RS-4326	↓	↓	.05	None
D ₂	RS-3857	RS-3862	RS-3863	RS-5504	↓	12K	8.2K	27K	3.3K	8.2K	RS-4326	↓	↓	.05	None
E ₁	RS-3857	RS-3862	RS-3863	RS-5504	↓	12K	8.2K	27K	3.3K	8.2K	RS-4326	↓	↓	.05	None
E ₂	RS-3868	RS-3862	RS-3863	RS-5504	↓	18K	5.6K	27K	3.3K	8.2K	RS-4326	↓	↓	.05	None
E ₃	RS-5104	RS-3862	RS-3863	RS-5504	↓	22K	Omit	27K	3.3K	8.2K	RS-4326	.01	.01	.05	None
E ₄	RS-5104	RS-5201	RS-5301 or RS-5303	RS-5504	↓	22K	Omit	39K	Omit	12K	RS-4326	.01	.01	.05	7.5mmf
F	RS-5104	RS-5201	↓	RS-5504	↓	22K	Omit	39K	Omit	12K	RS-4707	.01	.01	.05	7.5mmf
G	RS-3868	RS-5201	↓	RS-5504	↓	18K	Omit	39K	Omit	12K	RS-4707	.05	.005	.05	7.5mmf
H	RS-3868	RS-5201	↓	RS-5504	↓	18K	Omit	39K	Omit	12K	RS-4707	.05	.005	.05	7.5mmf
J	RS-3868	RS-3862	RS-3863	RS-5504	↓	18K	8.2K	27K	Omit	8.2K	RS-4707	.005	.005	.01	Omit
K	RS-5104	RS-5201	RS-5301 or RS-5202 or RS-5203	RS-5504	↓	22K	Omit	39K	Omit	12K	RS-4707	.01	.01	.05	7.5mmf
L	RS-3868	↓	RS-5310	RS-5504	↓	18K	Omit	39K	Omit	12K	RS-4707	.005	.005	.05	6.8mmf
M	RS-3868	↓	RS-5304 or RS-5309	RS-5504	↓	18K	Omit	39K	Omit	12K	RS-4707	.005	.005	.05	6.8mmf

① BOTH TR5 and TR6 must be the same type transistor.

COMPONENT WIRING DIAGRAM—MODELS P910 AND P895 F, G, J, L, M

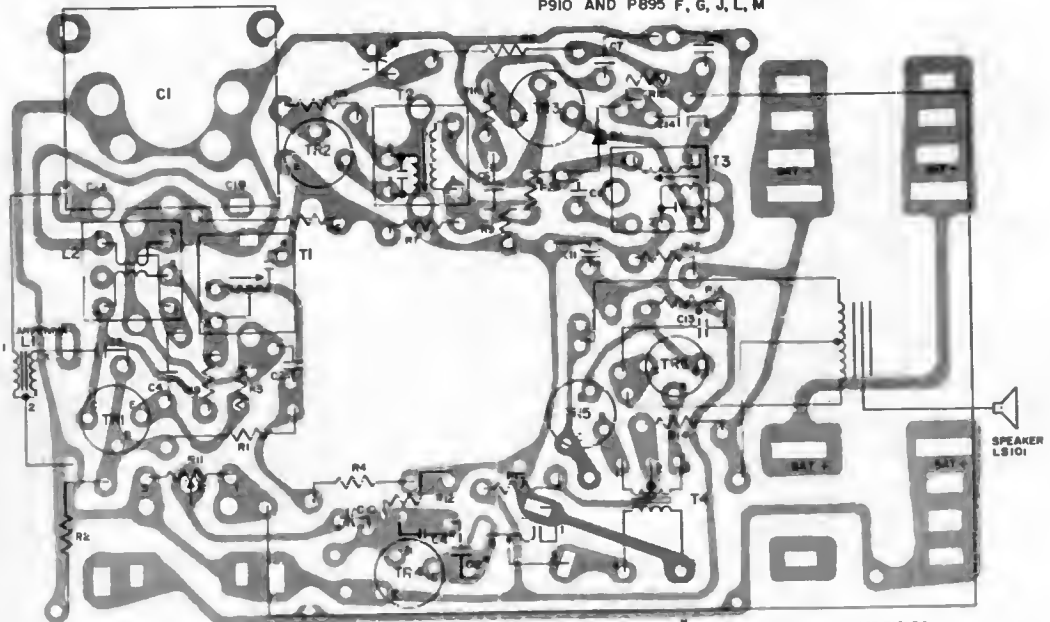

*NOT FOUND IN ALL VERSIONS SEE TABLE 2

GENERAL ELECTRIC

MODELS
P807G, H
P807S, T
P808G, H
P808S, T

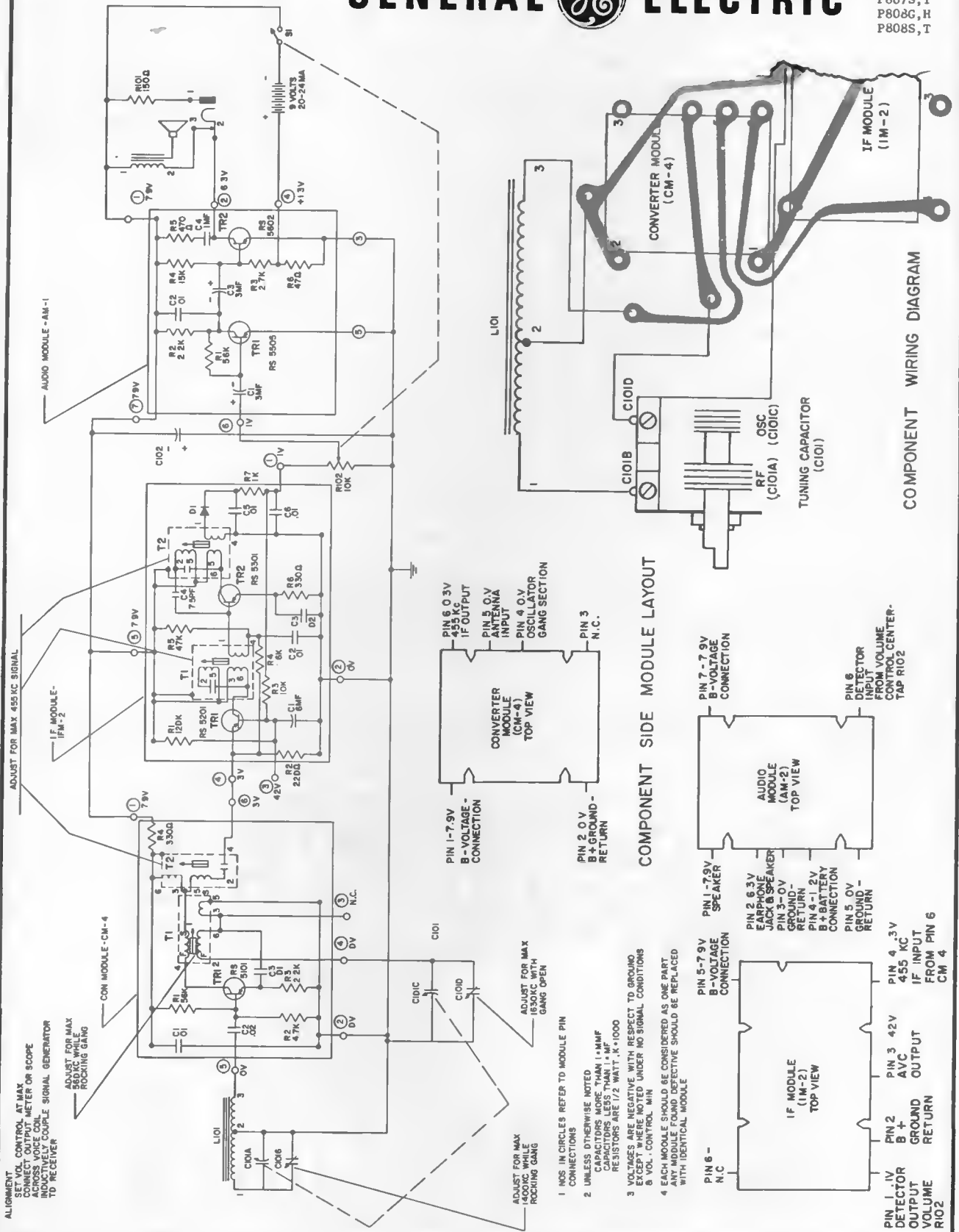

GENERAL ELECTRIC

Models P915A, B, P916A, B, P917A, B, P9151A, B, P9161A, B, P9171A, B

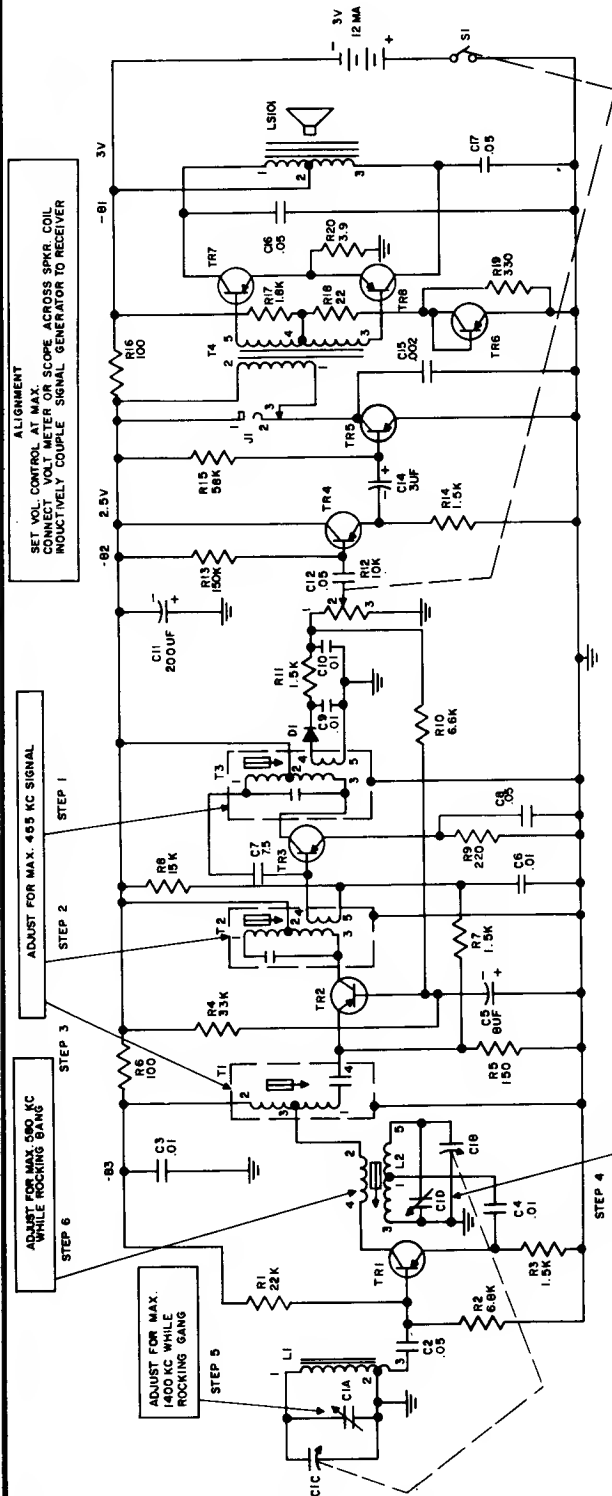

TROUBLESHOOTING (CONT'D)

If an excessive total quiescent current drain is recorded, the individual collector currents of each transistor should be checked. An excessive current reading may mean a shorted transistor; no current will indicate that a transistor or associated circuit component is defective.

NO RECEPTION:

1. Check battery voltage and battery contacts.
2. Check on-off switch.
3. Check all antenna lead connections.
4. Check coil L2.

WEAK AUDIO:

1. Check battery voltage for 3 volts.
2. Check battery current.
3. Check transistor collector currents.
4. Check alignment.

INTERMITTENT:

1. Check battery contacts for corrosion.
2. Check solder connections on dip-soldered side of circuit board.

Intermittent audio, motorboating, and poor reception is frequently caused by poor battery contact.

CHASSIS REMOVAL

1. Remove the dial knob screw with a small Phillips screw driver and lift off the dial knob.
2. Remove cabinet back by inserting a coin in the slot on the bottom of the set, giving it a slight twist.
3. Remove two 1/8" Phillips-head screws located underneath the batteries.
4. Remove 1/8" Phillips-head screw located next to the tuning capacitor.
5. Slide out the circuit board in the direction of the cabinet bottom and lift out.

TROUBLESHOOTING

A check of battery condition and total current drain of the receiver should be made first. All current measurements are made at quiescence with the receiver turned on, volume control at minimum, tuning gang closed, and with no-signal conditions.

The total quiescent receiver current drain is 12 to 14 mils. This is measured by inserting a milliammeter in series with the batteries.

TABLE OF TRANSISTOR VOLTAGES		FUNCTION	
EMITTER	BASE	COLLECTOR	
TR1	0.7	0.8	1. 2.4 CONVERTER
TR2	0.15	0.3	2. NO I.F. AMP
TR3	0.2	0.35	2.5 3RD. I.F. AMP.
TR4	0.75	0.8	2.5 1ST. AUDIO
TR5	0	0.3	2.2 AUDIO DRIVER
TR6	0	0.15	0.15 CURRENT REGULATOR
TR7	0.04	0.15	3.0 PUSH PULL AUDIO OUTPUT
TR8	0.04	0.15	3.0 AUDIO OUTPUT

GENERAL ELECTRIC

RADIO
MODEL
P925A

TABLE OF VOLTAGES*

	E	B	C
TR1	0.7	0.8	4.5
TR2	1.1	1.3	4.5
IM-1	PIN 1	PIN 2	PIN 4
	0.08	0	0.18
	PIN 1	PIN 3	PIN 4
	0.08	4.0	0.2
AM-4	PIN 6	PIN 7	PIN 8
	3.0	3.1	3.1
	PIN 10	PIN 11	PIN 12
	0	4.7	0.18

*R7 SET AT MIO-POSITION

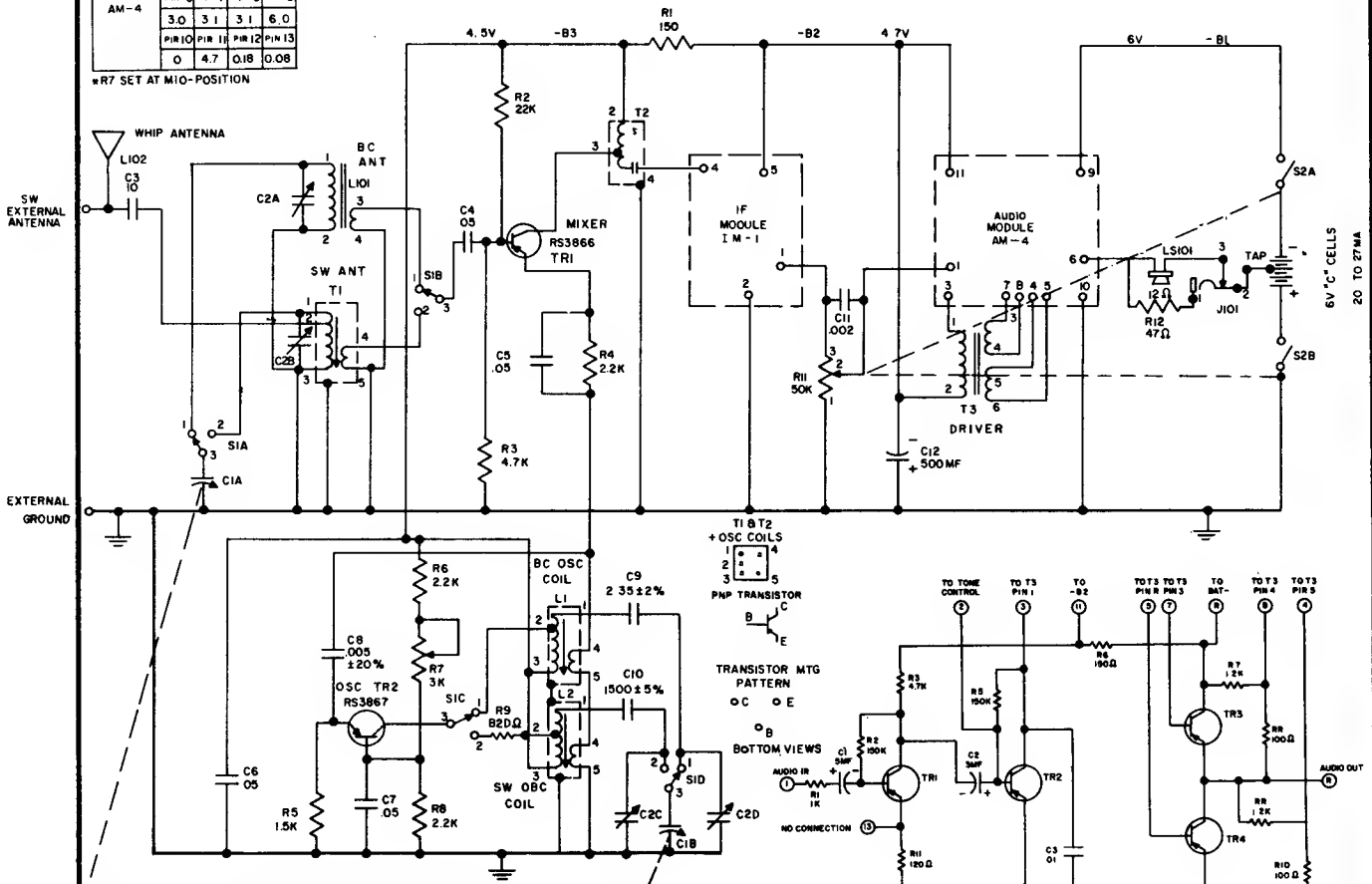

EXTERNAL GROUND

6V "C" CELLS
20 TO 27MA

SWEEP AND PEAK ALIGNMENT PROCEDURES

STEP	SIGNAL GEN. INPUT	BAND SWITCH	TUNING GANG	AM GEN.	SWEEP GEN.	ADJUST THE FOLLOWING:	CONNECT VTVM ACROSS	CONNECT SCOPE ACROSS	REMARKS
1	Inductively Couple to AM Antenna Loop (L101)	BC	Open	455KC		T2, T1 of IF Module (IM-1), T2 of the circuit board.	Voice Coil	Voice Coil	
2	High side to External SW Ant. terminal, Low side to External Ground terminal.	**SW	12MC	12MC		C2C for Maximum Amplitude	Voice Coil	Voice Coil	Adjust Signal Generator to 910 KC above wanted frequency to observe image frequency response.
3	High side to External SW Ant. terminal, Low side to External Ground terminal.	SW	4MC	4MC		L2 for Maximum Amplitude	Voice Coil	Voice Coil	Adjust Signal Generator to 4MC above wanted frequency to observe image frequency response.
4	Repeat steps 1 and 2 until no further adjustment is required.								
5	High side to External SW Ant. terminal, Low side to External Ground terminal.	SW	12MC	12MC	*12MC	C2B for Maximum Amplitude	Voice Coil	*Across pin 1 of IF Module (IM-1) and Ground	*Adjust Sweep width control or center frequency to observe image response.
6	High side to External SW Ant. terminal, Low side to External Ground terminal.	SW	4MC	4MC	*4MC	T1 for Maximum Amplitude	Voice Coil	*Across pin 1 of IF Module (IM-1) and Ground	*Adjust Sweep width control or center frequency to observe image response.
7	Repeat steps 4 and 5 until no further adjustment is required.								
8	Inductively Couple to AM Antenna Loop	BC	Open	1630 KC		C2D for Maximum Amplitude	Voice Coil	Voice Coil	
9	Inductively Couple to AM Antenna Loop	BC	1400 KC	1400 KC	*1400 KC	C2A for Maximum Amplitude	Voice Coil	Voice Coil	*Rock Geng during Peak Alignment
10	Inductively Couple to AM Antenna Loop	BC	380 KC	380 KC	*380 KC	L1 for Maximum Amplitude	Voice Coil	Voice Coil	*Rock Geng during Peak Alignment
11	Repeat steps 7, 8 and 9 until no further adjustment is required.								

* SWEEP ALIGNMENT ONLY

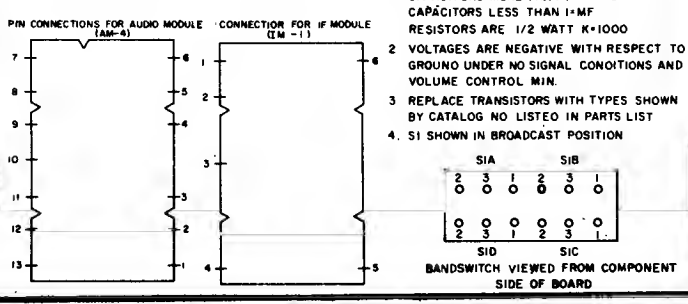
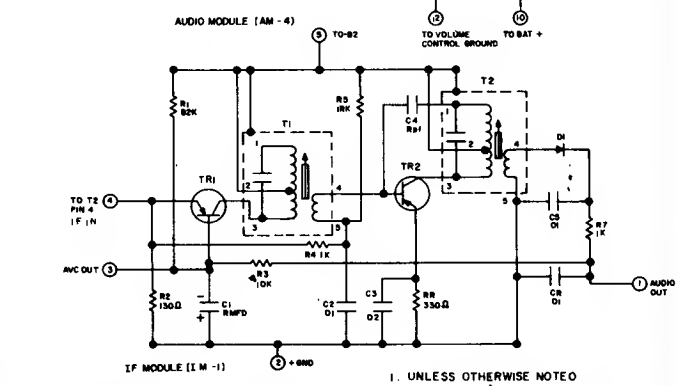
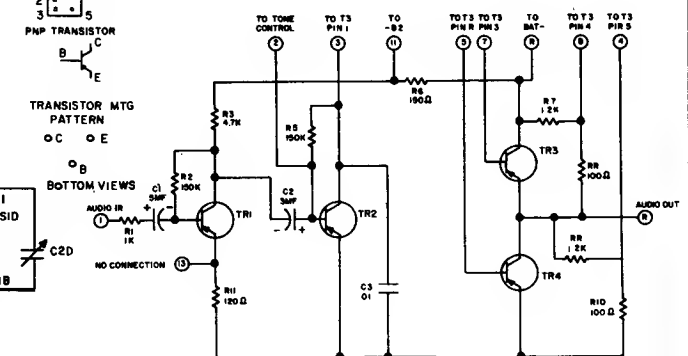

- UNLESS OTHERWISE NOTED CAPACITORS MORE THAN 1MMF OR PF CAPACITORS LESS THAN 1MMF RESISTORS ARE 1/2 WATT K-1000
- VOLTAGES ARE NEGATIVE WITH RESPECT TO GROUND UNDER NO SIGNAL CONDITIONS AND VOLUME CONTROL MIN.
- REPLACE TRANSISTORS WITH TYPES SHOWN BY CATALOG NO LISTED IN PARTS LIST
- S1 SHOWN IN BROADCAST POSITION

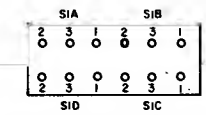

BANDSWITCH VIEWED FROM COMPONENT SIDE OF BOARD

GENERAL ELECTRIC

MODEL P955A

MODULES

This radio uses three high-reliability modules in its construction. The modules are self-contained circuit stages, each grouped on a miniature circuit board, which themselves are mounted on and soldered into the main circuit board just like any other component (transistor, capacitor, etc.).

This method of manufacture provides high reliability at an optimum cost. In fact, it allows the cost of the module to fall into the same range as tubes or transistors. This means that defects in the circuits involved in the modules need only be replaced with a good unit.

Almost always this will result in an easier, quicker, and more economical repair than would be possible if the serviceman were to try to locate and replace a defective component within a module. This radio uses such modules in the converter, I. F. and Audio stages.

CHASSIS REMOVAL

1. Remove volume and tuning knobs.
2. Remove two Phillips-head screws from cabinet back.
3. Remove seven hex-head screws from circuit board.
4. Label and unsolder wires going to speaker and battery terminals.
5. Carefully lift circuit board from cabinet.

TROUBLESHOOTING

IMPORTANT: The audio output terminals of the radio must be D. C. isolated from ground during servicing procedures. This is to prevent the audio output transistors from becoming damaged by excess voltages in the audio circuit. Therefore, care must be exercised in using test equipment that may cause a D. C. path to ground.

The total battery current drain should always be ascertained before proceeding with the servicing. These current readings should be taken with the receiver in the "OFF" position. Total current is measured by placing a jumper across S1A and measuring the current across the switch terminals of S1B. This current reading should fall between 20-27 MA. After noting this current, remove the jumper across S1A and place it across the terminals of S1B. Measure the current drain across the switch terminals of S1A. This current reading should be approximately the same as the previous reading. Should any significant difference in current readings occur when making this check, a defective audio output stage is indicated.

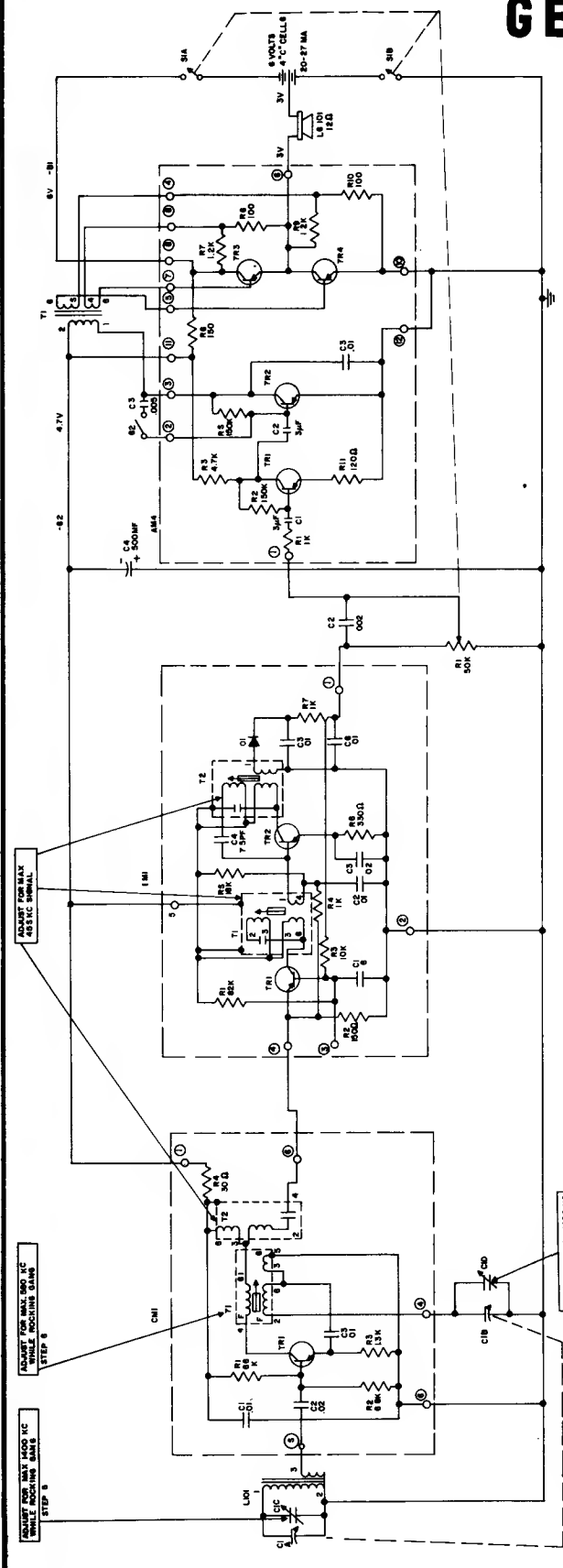

ADJUST FOR MAX. 455 KC SIGNAL
STEP 8

ADJUST FOR MAX. 100 IC WHILE ROCKING GANG
STEP 9

ADJUST FOR MAX. 100 IC WHILE ROCKING GANG
STEP 9

ADJUST FOR MAX. 100 IC WITH GANG OPEN

1. VOLTAGE NEGATIVE WITH RESPECT TO GROUND UNDER NO SIGNAL CONDITIONS
2. UNLESS OTHERWISE NOTED CAPACITORS MORE THAN 1-100PF RESISTORS ARE 1/2 WATT ± 1000 Ω 3. 33 SHOWN IN HITRENET POSITION

TABLE OF VALUES

CH	TR1	TR2	TR3	TR4
M-1	PN1	PN2	PN3	PN4
M-2	PN5	PN6	PN7	PN8
M-3	PN9	PN10	PN11	PN12

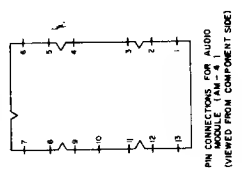
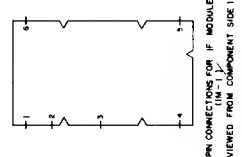
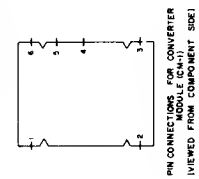

GENERAL ELECTRIC

MODELS T215A, T216A, T265A, T266A, C540A and C541A

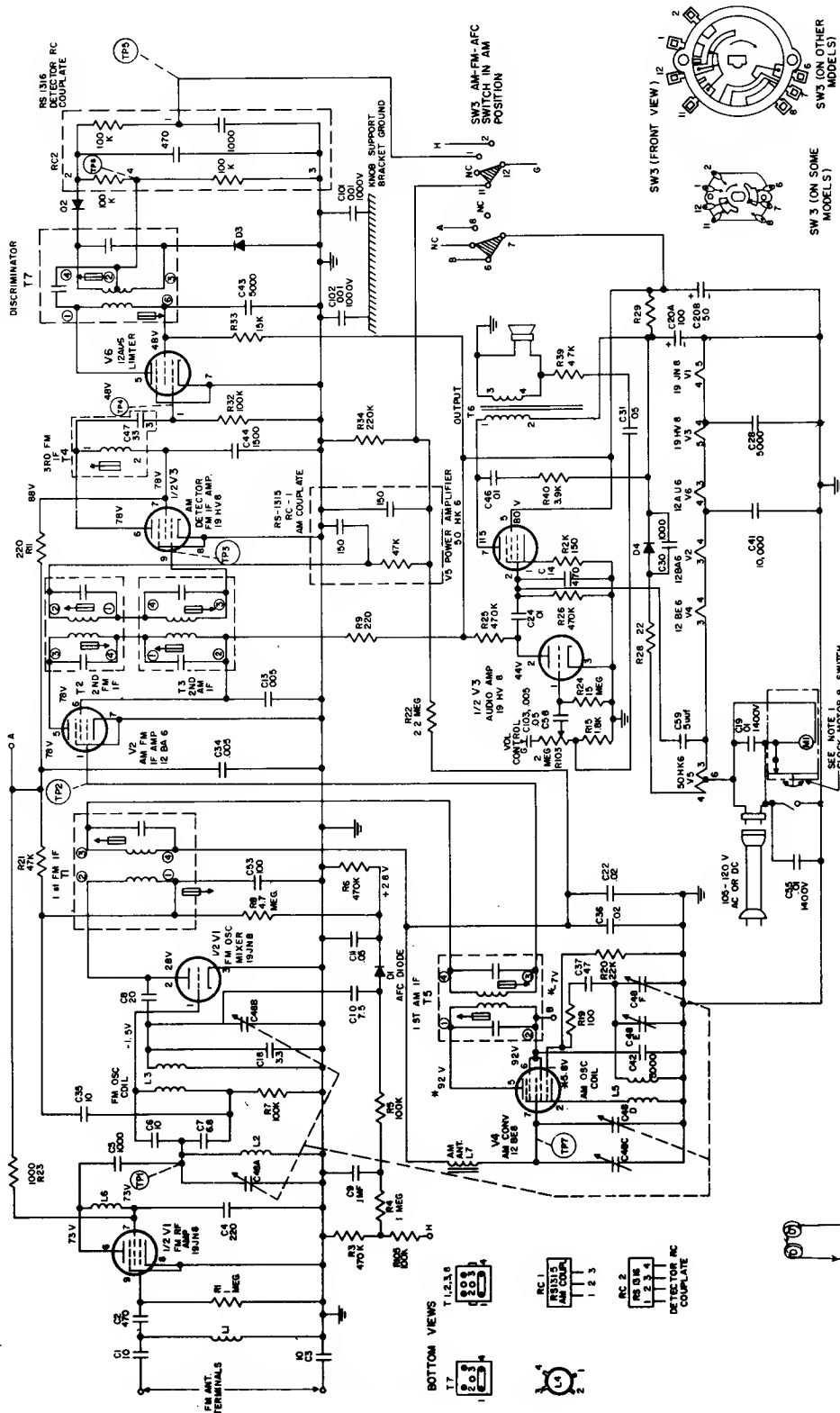

ELECTRICAL RATING: 105 - 120 Volts AC, 30 Watts
 TUNING RANGE: AM 540 - 1600 KC
 FM 88 - 108 MC
 I. F. : AM 455 KC
 FM 10.7 MC
 POWER OUTPUT: Undistorted .8 Watt
 Maximum 1.5 Watts

UNLESS OTHERWISE NOTED:
 K = 1000 M = 1,000,000
 CAP MORE THAN 1-MHF
 CAP LESS THAN 1-MHF

VOLTAGE READINGS TAKEN WITH VTVM
 1. SET IN AM POSITION
 2. SET IN FM POSITION
 3. VOLUME CONTROL AT MIN
 4. TUNING DIAL SET TO 108 MC
 * SET IN AM POSITION
 NOTE: USE ONLY ON C540A AND C541A

GENERAL ELECTRIC

MODEL RP-1590A, C

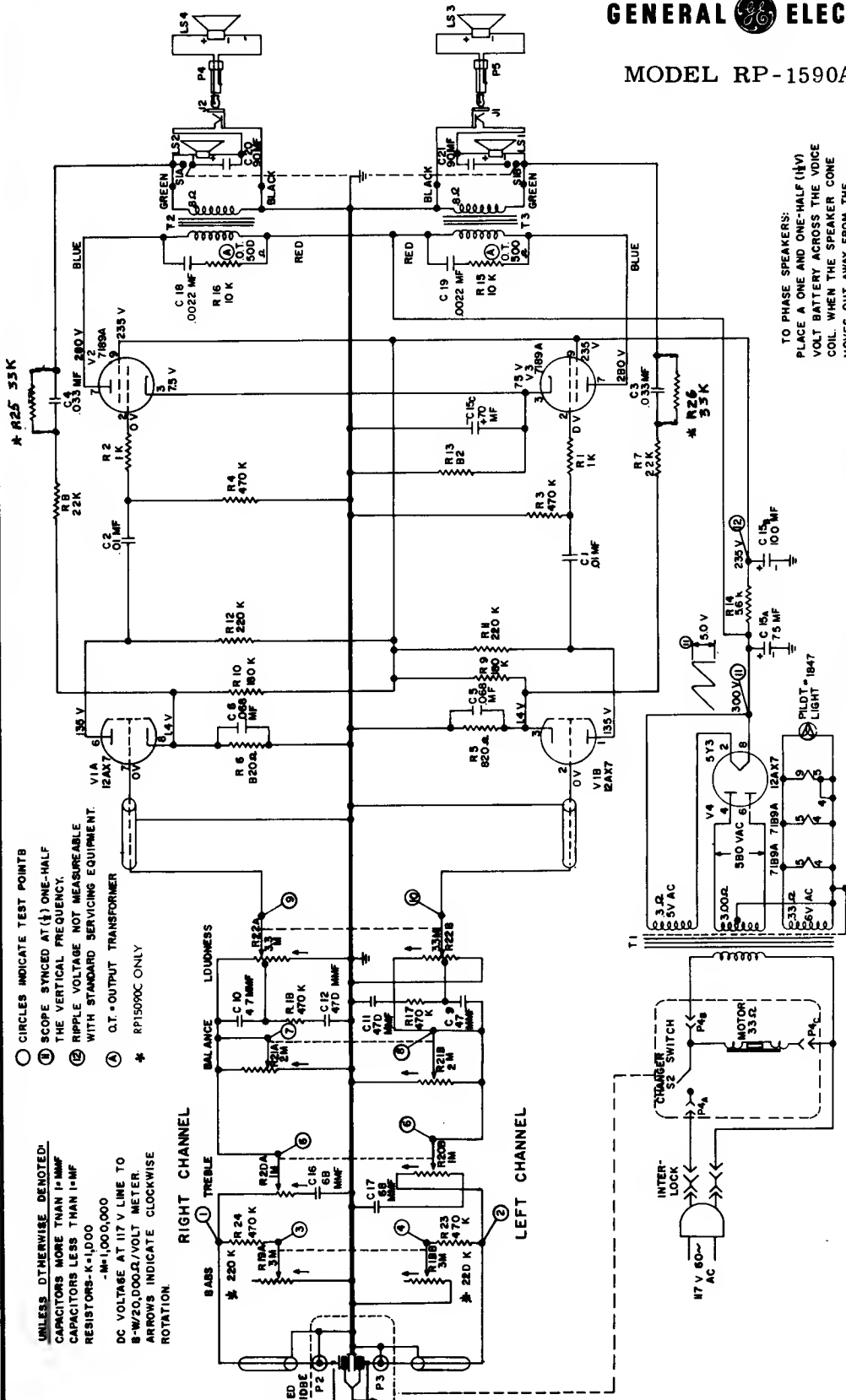

- CIRCLES INDICATE TEST POINTS
- ① SCOPE SYNCED AT (1) ONE-HALF THE VERTICAL FREQUENCY.
- ② RIPPLE VOLTAGE NOT MEASURABLE WITH STANDARD SERVICING EQUIPMENT.
- Ⓐ O.T. OUTPUT TRANSFORMER
- * RP1590C ONLY

UNLESS OTHERWISE DENOTED:
 CAPACITORS MORE THAN 1 μF = MF
 CAPACITORS LESS THAN 1 μF = MFC
 RESISTORS - K = 1,000
 - M = 1,000,000
 DC VOLTAGE AT 117 V LINE TO 5-W/20,000 Ω/VOLT METER.
 ARROWS INDICATE CLOCKWISE ROTATION

TO PHASE SPEAKERS:
 PLACE A ONE AND ONE-HALF (1½) VOLT BATTERY ACROSS THE VOICE COIL WHEN THE SPEAKER CONE MOVES OUT, AWAY FROM THE MAGNET, THE POSITIVE TERMINAL ON THE BATTERY IS THE PLUS SIDE OF VOICE COIL AS INDICATED ON SCHEMATIC.

1. Remove the three screws on the tube replacement cover and remove the cover.
2. Remove the two screws on the metal amplifier cover and remove the cover by pulling up on the tab provided on the back side and lift the cover out.
3. Reach under the motor board and flip the right side shipping screw clip to a vertical position. Lift the right side of the changer to clear the shipping screw clip and slip the left shipping screw through the slotted hole in the motor board to clear the changer. Rest the changer on its back edge in the compartment.
4. Remove the screw on the perforated back cover and remove the cover.
5. Follow steps 1 through 5 as described in "To Remove Record Changer."
6. Remove the control knobs, (pull up).
7. Remove the three screws on the control panel escutcheon and remove the escutcheon.
8. Remove the screw on the perforated back cover and remove the cover.
9. Remove the two 5/16 inch nuts holding the left and right channel output jacks at the rear of the compartment.
10. Remove the two 5/16 inch nuts holding the amplifier chassis.
11. Unsolder the speaker leads, and label to assure the correct speaker phasing when reassembling the set.
12. Remove the pilot light socket from the clip, (pull up).
13. Unsolder the speaker leads, and label to assure the correct speaker phasing when reassembling the set.
14. Remove the chassis from the cabinet.

5. Remove the three screws located at both ends and front center of the control panel mounting board and remove the board.

6. Remove the two 5/16 inch nuts holding the control panel to the mounting board.

7. Unsolder the four (4) leads on the expanded stereo switch.

8. Remove the screws holding the lead dresser and electrolytic.

9. Remove the three 5/16 inch nuts holding the amplifier chassis.

4. Remove the signal and power plugs from the changer.

5. Remove the changer from the cabinet.

TO REMOVE CHASSIS

TO REMOVE RECORD CHANGER

VOLUME R-24, MOST-OFTEN-NEEDED 1964 RADIO SERVICING INFORMATION

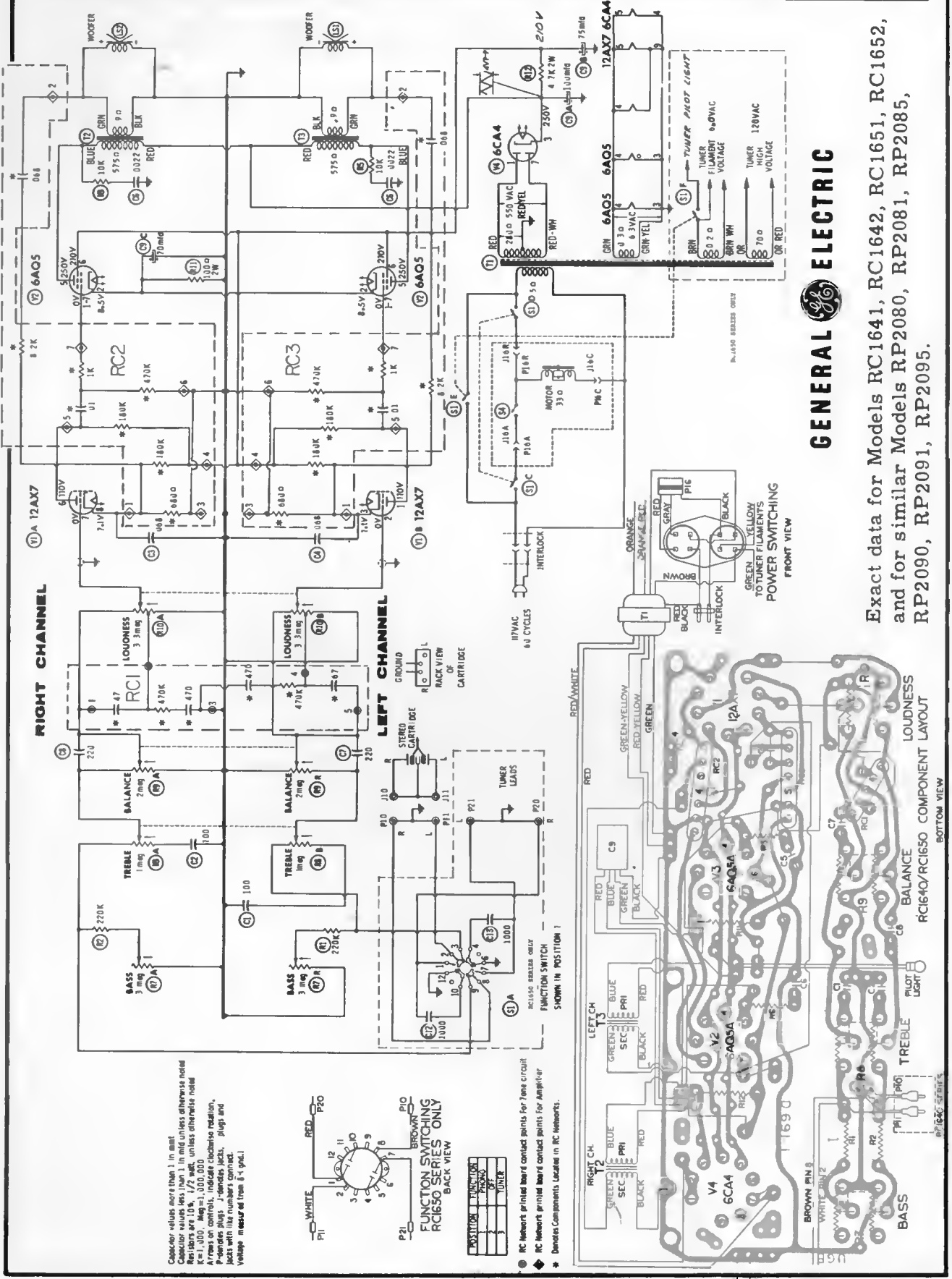

GENERAL ELECTRIC

Exact data for Models RC1641, RC1642, RC1651, RC1652, and for similar Models RP2080, RP2081, RP2085, RP2090, RP2091, RP2095.



RP2130 Series, Models RP2131A, RP2138A,
 RP2110 Series, Models RP2111 & RP2113,
 Models of the RP1530 Series are very similar.

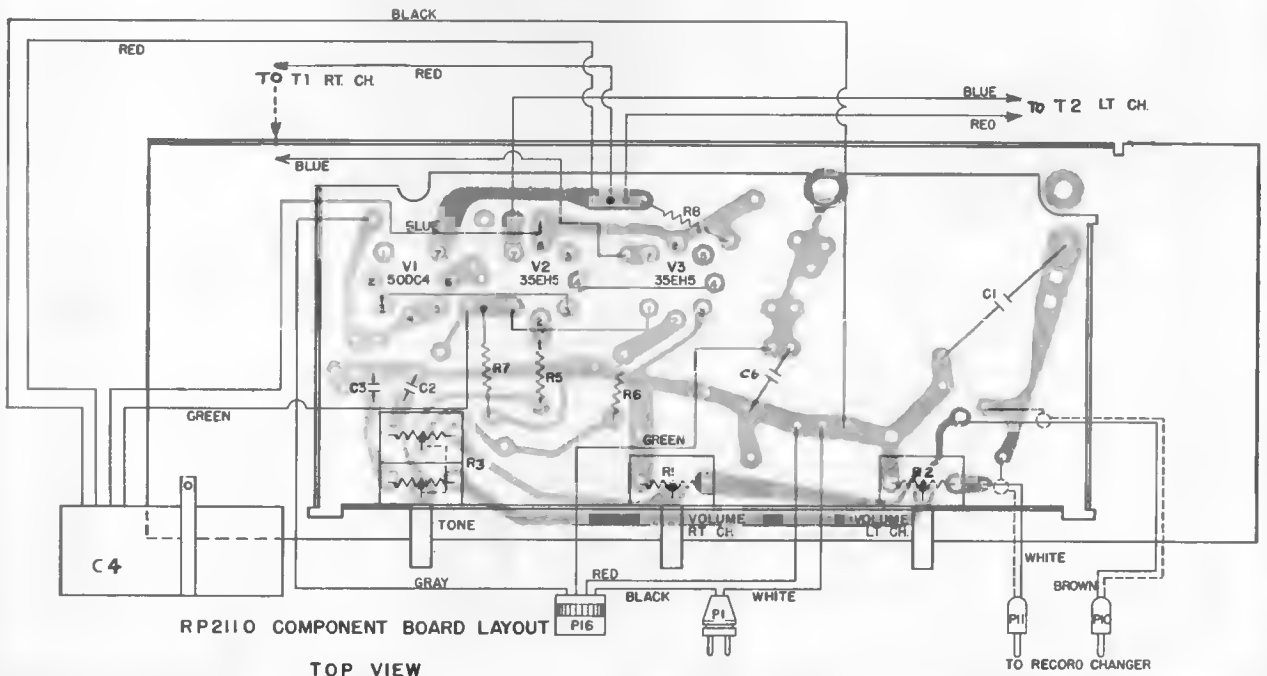
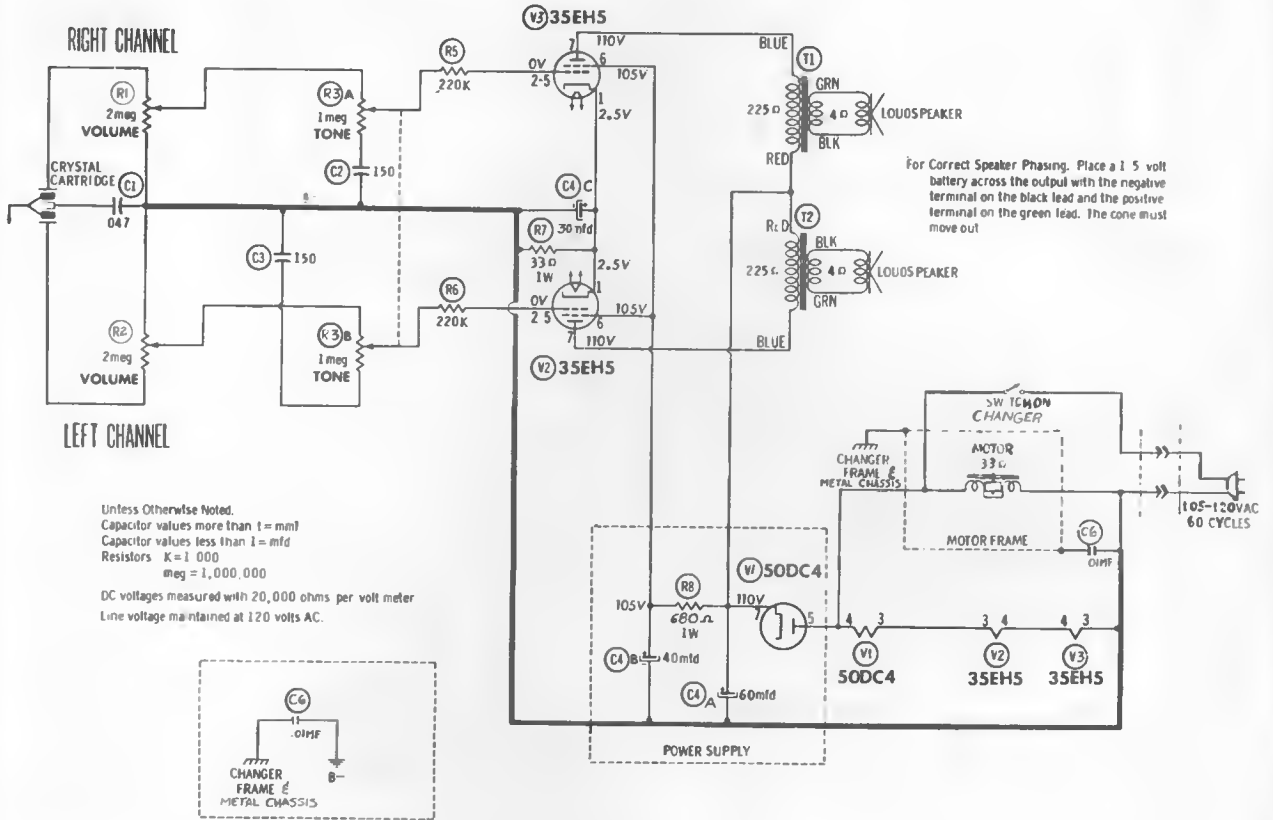

Hitachi, Ltd.

MODEL TH-650

CIRCUIT SYSTEM 6-transistor superheterodyne
 TUNING RANGE 535 kc~1,605 kc
 INTERMEDIATE FREQUENCY 455 kc

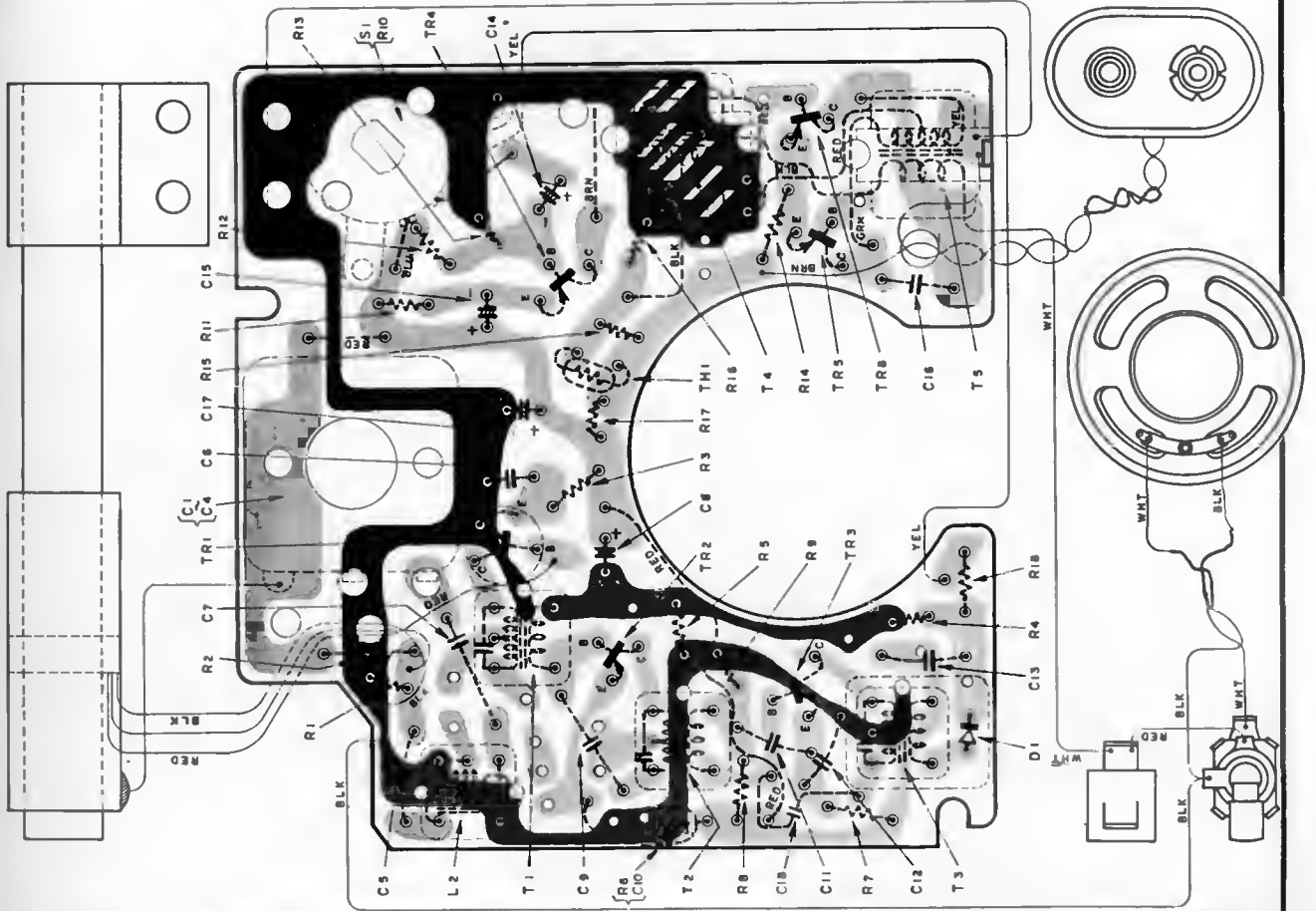
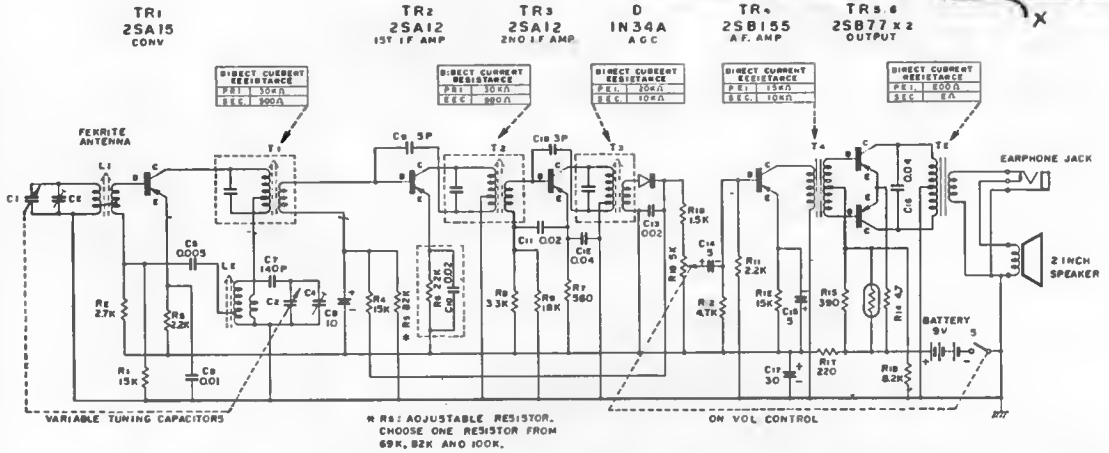
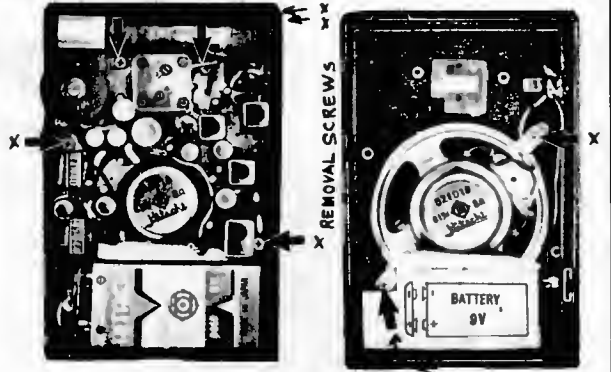

Magnavox

93 SERIES AMPLIFIER CHASSIS

(93-01, 93-02, 93-03, 93-04, & 93-05)

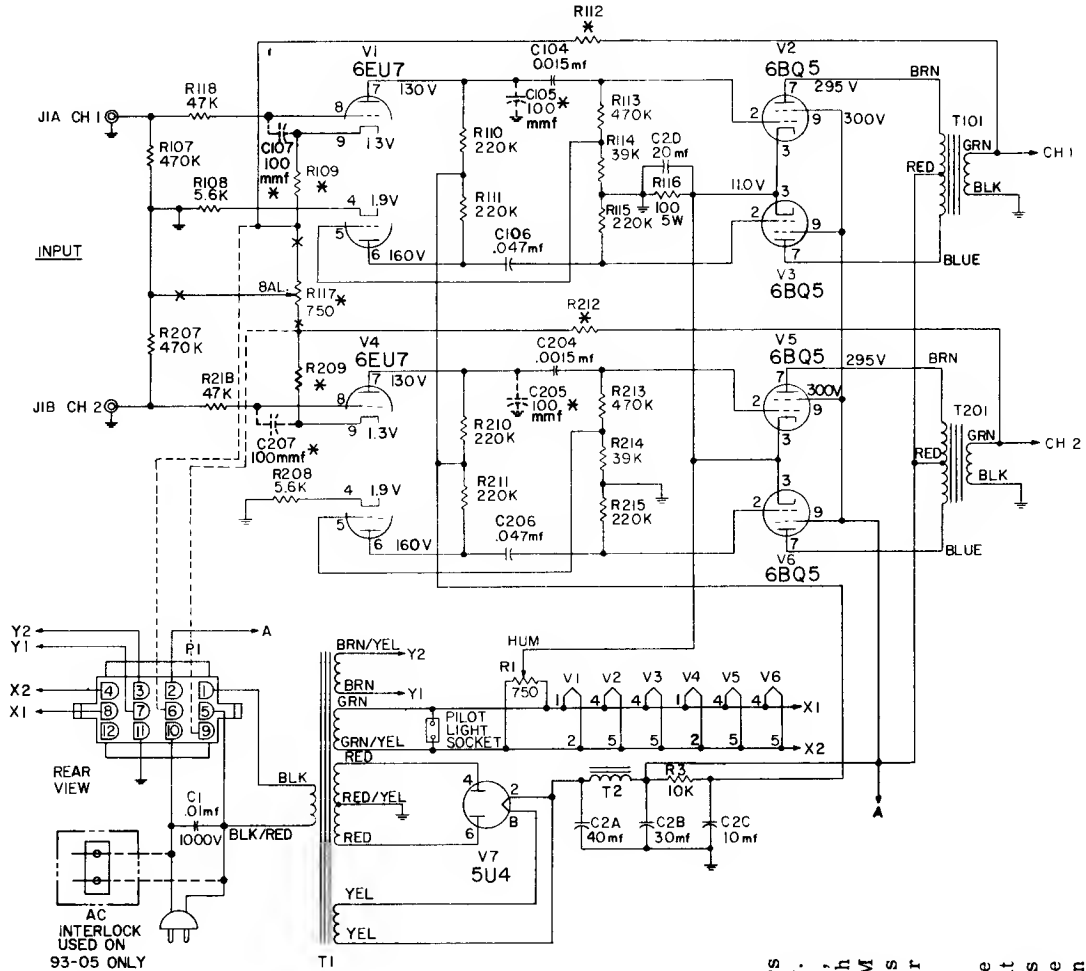

CHASSIS	R109	R209	R112	R212	R117	C105	C205	C107	C207
93-01-00	4700	4700	2200	2200	USE	USE	USE	OMIT	OMIT
93-02-00	2200	2200	3900	3900	USE	USE	USE	OMIT	OMIT
93-02-10	2200	2200	3900	3900	USE	OMIT	OMIT	USE	USE
93-03-00	4700	4700	2200	2200	OMIT	USE	USE	OMIT	OMIT
93-03-10	4700	4700	2200	2200	OMIT	OMIT	OMIT	USE	USE
93-04-00	2200	2200	3900	3900	OMIT	USE	USE	OMIT	OMIT
93-04-10	2200	2200	3900	3900	OMIT	OMIT	OMIT	USE	USE
93-05-00	4700	4700	2200	2200	OMIT	OMIT	OMIT	USE	USE

* When Balance Control (R117) is not used the Power Connector will have two additional connections as shown in dotted lines.

The 93 Series Amplifiers are Stereo Amplifiers designed to work in conjunction with an AM-FM Tuner. These chassis contain seven tubes, including rectifier, and provide approximately 15 watts output for each channel. All voltages, including those for the AM-FM Tuner are obtained from these amplifiers. This necessitates using a 5U4 as a rectifier and a heavier power transformer than is normally used.

The 93-01 and 93-02 Amplifiers contain a "Balance Control". This control is located in the cathode circuit of (1/2) of the 6EU7 used as the Audio Amplifier. This control will vary the output of each channel to assure proper balance when reproducing stereo records. On all others this control has been eliminated since these amplifiers are used with AM-FM Tuners which have the Balance Control as part of the tuner.

Magnavox

(59-11, & 59-14 & 59-27)

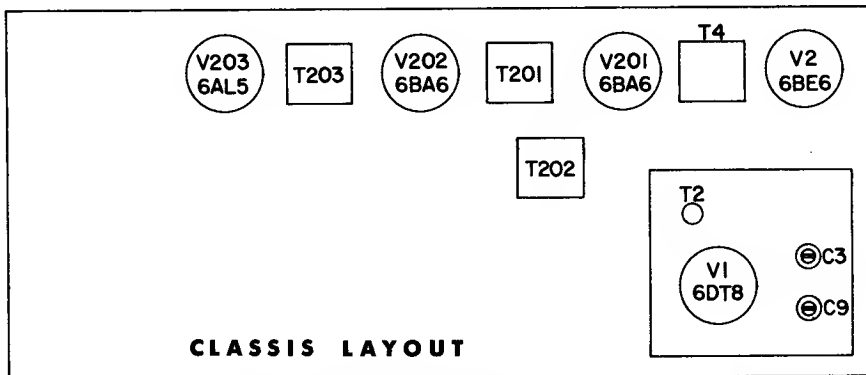
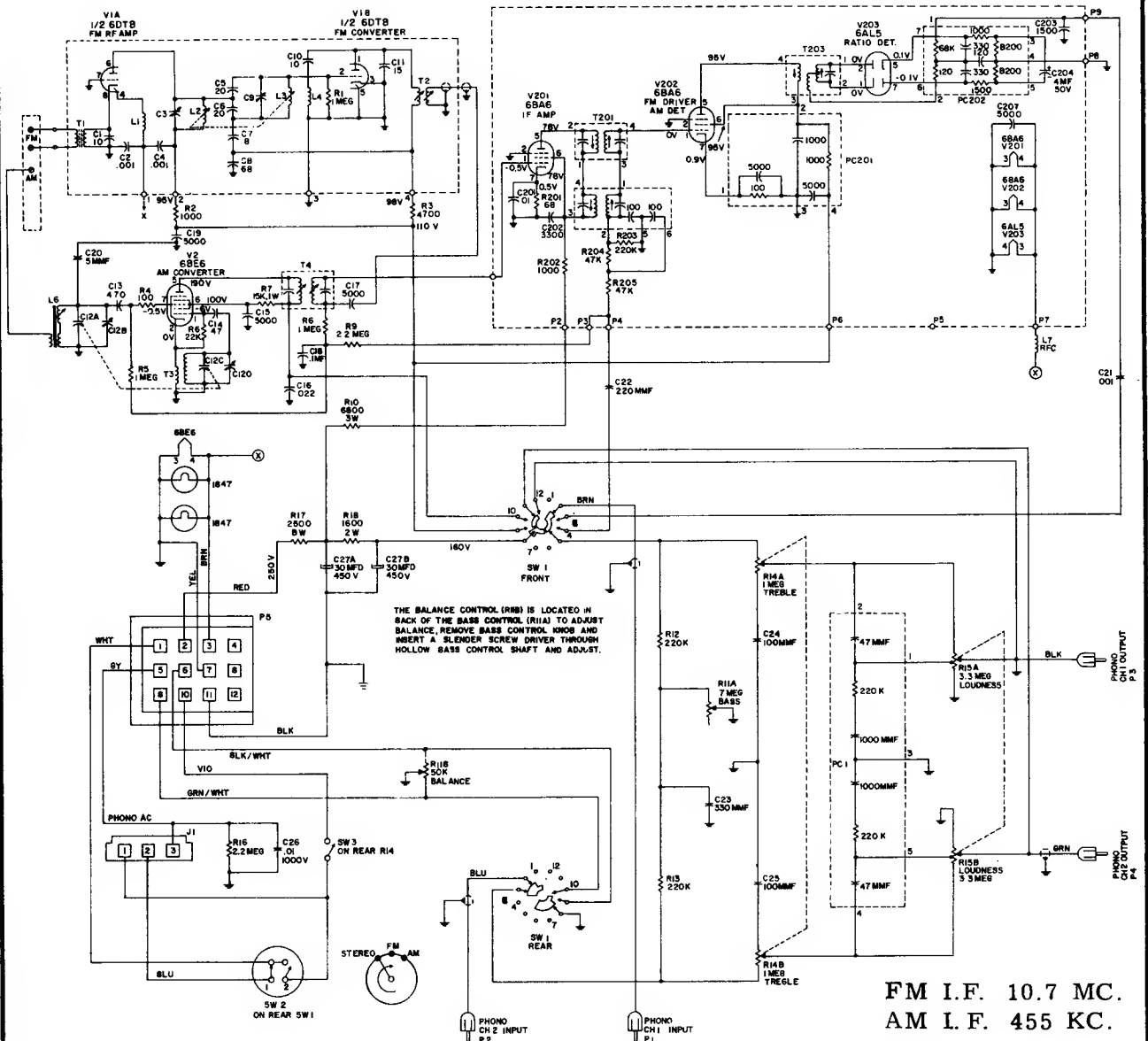

MONTGOMERY WARD

MODELS JWR-953A and JWR-1033B

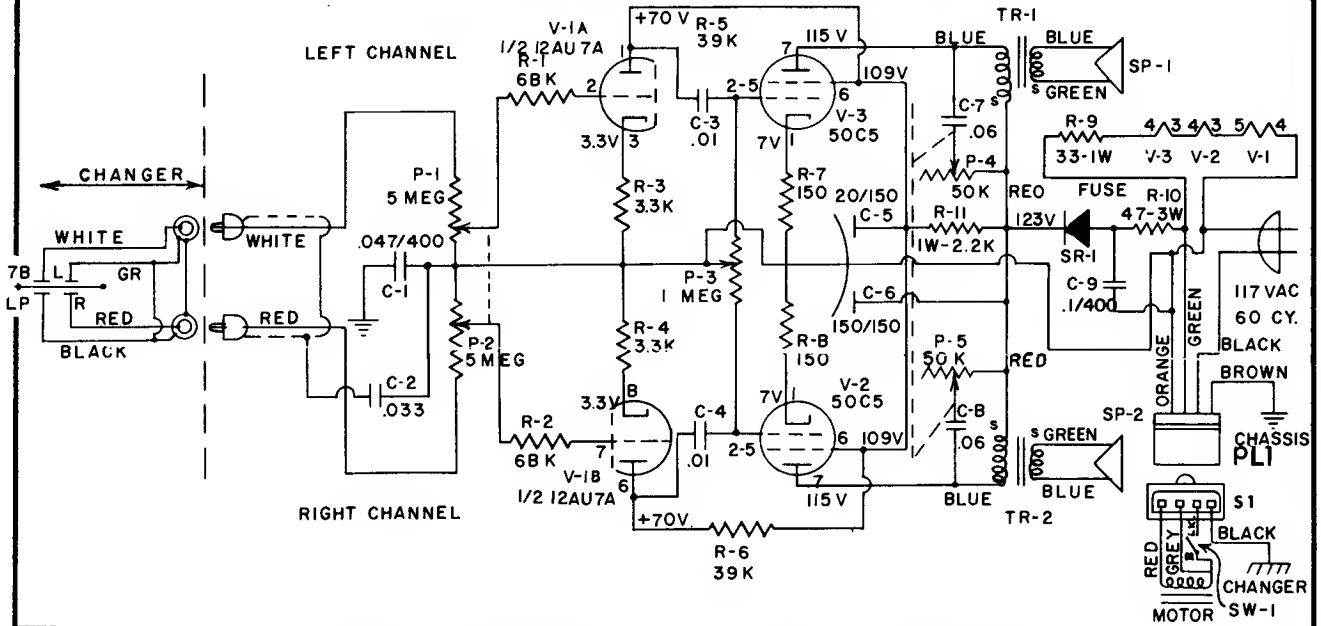

MONTGOMERY WARD Models JWR-956A and JWR-1035B

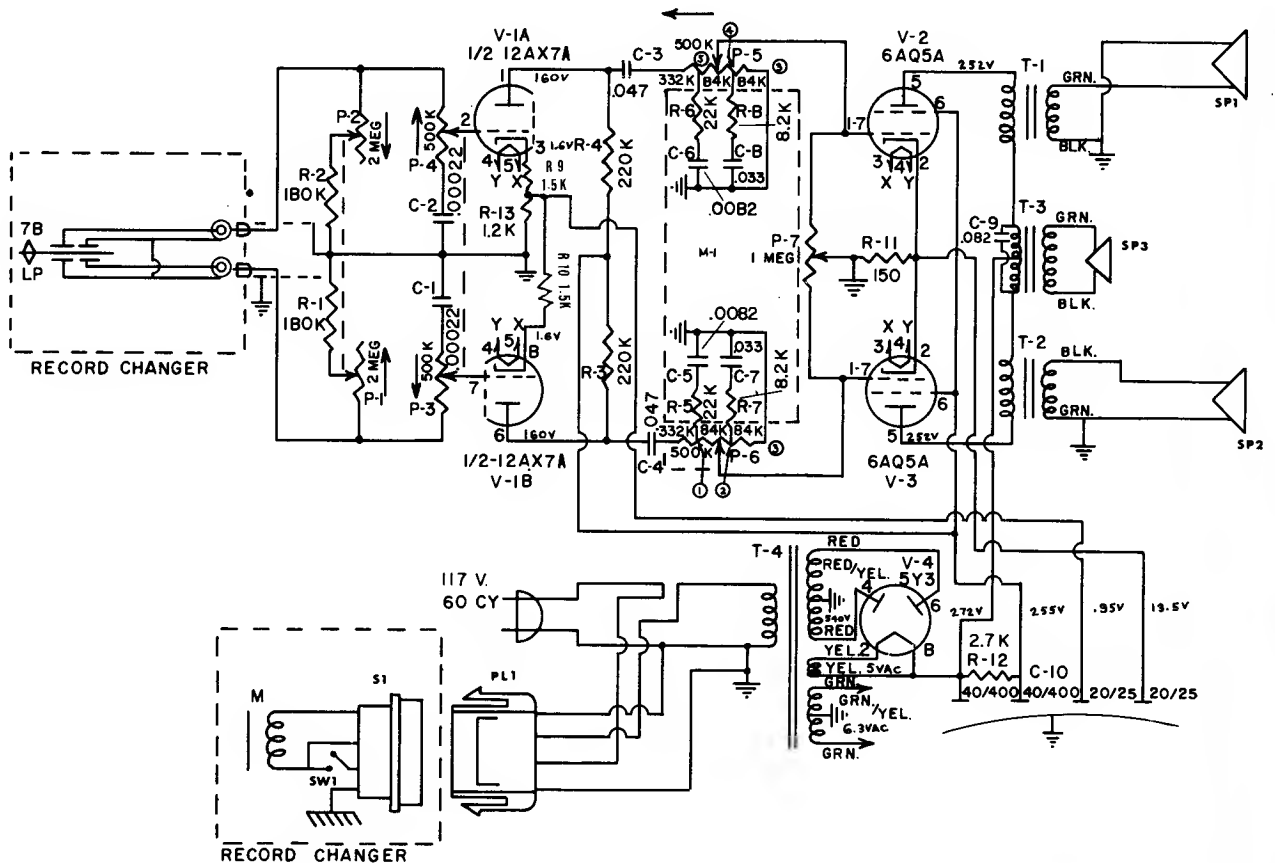

MONTGOMERY WARD

Model GEN-951A exact material. Model GEN-769A same less tone control.
 Models GEN-1730A, GEN-1731A, are also the same but less phono circuit.

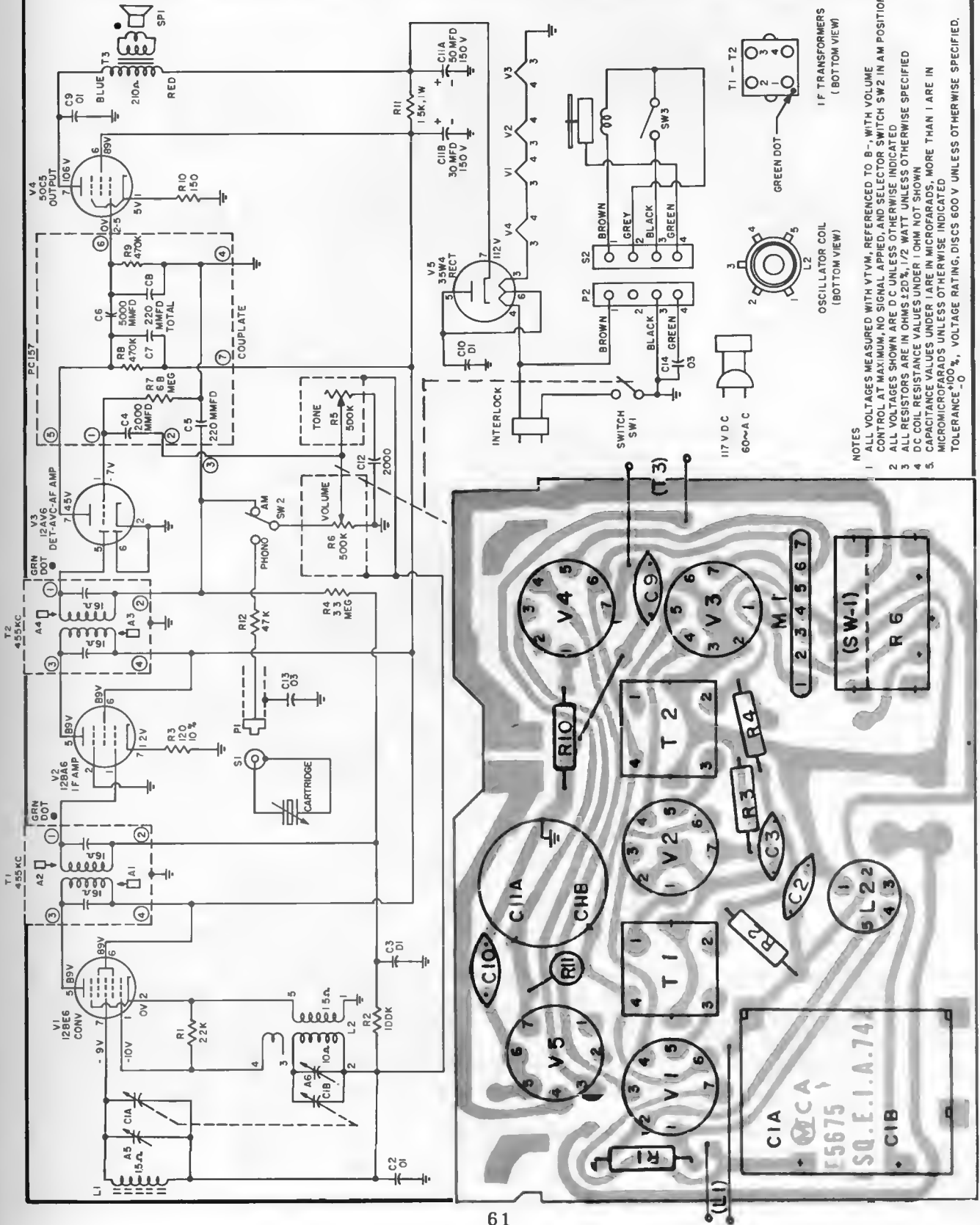

- NOTES
- 1 ALL VOLTAGES MEASURED WITH VTVM, REFERENCED TO B-, WITH VOLUME CONTROL AT MAXIMUM, NO SIGNAL APPLIED, AND SELECTOR SWITCH SW2 IN AM POSITION
 - 2 ALL VOLTAGES SHOWN ARE DC UNLESS OTHERWISE INDICATED
 - 3 ALL RESISTORS ARE IN OHMS 420%, 1/2 WATT UNLESS OTHERWISE SPECIFIED
 - 4 DC COIL RESISTANCE VALUES UNDER 1 OHM NOT SHOWN
 - 5 CAPACITANCE VALUES UNDER 1 ARE IN MICROFARADS, MORE THAN 1 ARE IN MICROMICROFARADS UNLESS OTHERWISE INDICATED.
- TOLERANCE $\pm 100\%$, VOLTAGE RATING, DISCS 600 V UNLESS OTHERWISE SPECIFIED.

Bottom View

MOTOROLA

Models 3AT and 3MT (Continued on the next page)

Models BKA63, CTA63, CTM63, and PCA63, are very similar.

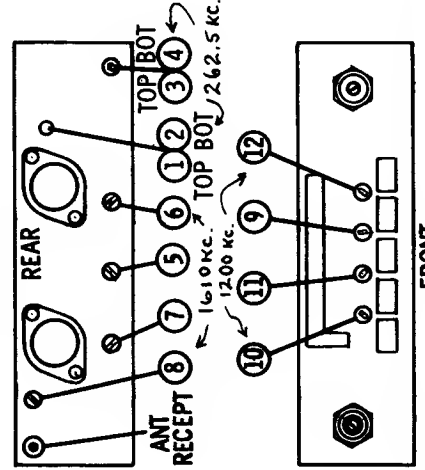
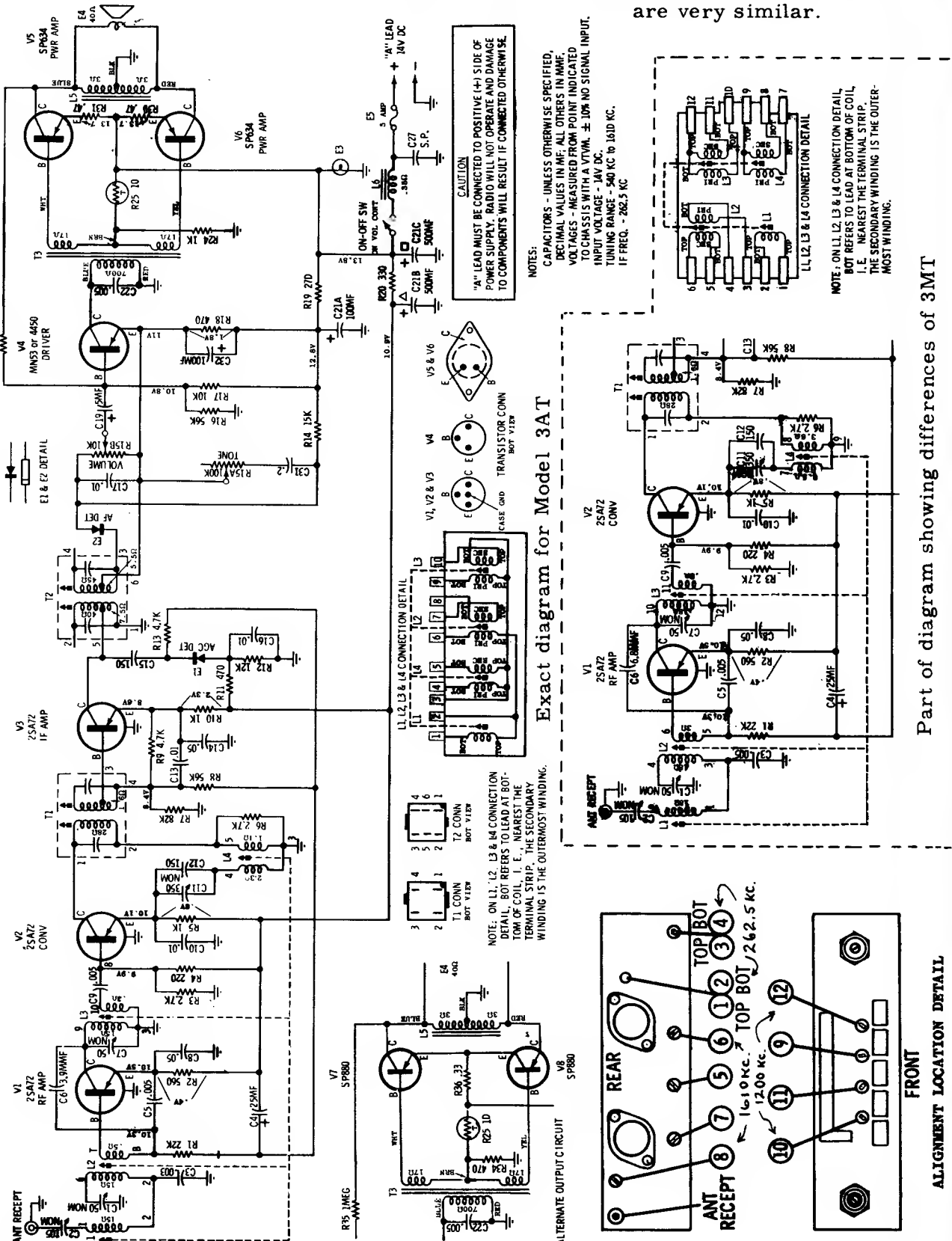

Part of diagram showing differences of 3MT

ALIGNMENT LOCATION DETAIL

VOLUME R-24, MOST-OFTEN-NEEDED 1964 RADIO SERVICING INFORMATION

MOTOROLA Model 3AT

Continued from preceding page, at left, other models listed on that page are very similar.

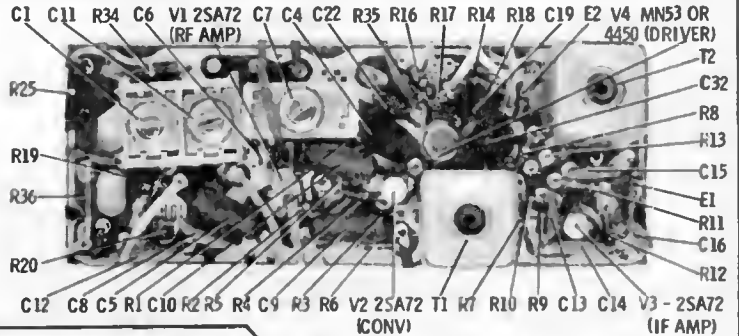

PARTS LOCATION FOR SETS USING ALTERNATE OUTPUT CIRCUIT

NOTES:
 -----PLATING ON COMPONENT SIDE
 * COMPONENT VALUES USED IN ALTERNATE OUTPUT CIRCUIT ONLY.
 # POINT CONNECTS TO GND THRU COMPONENT SIDE PLATING.

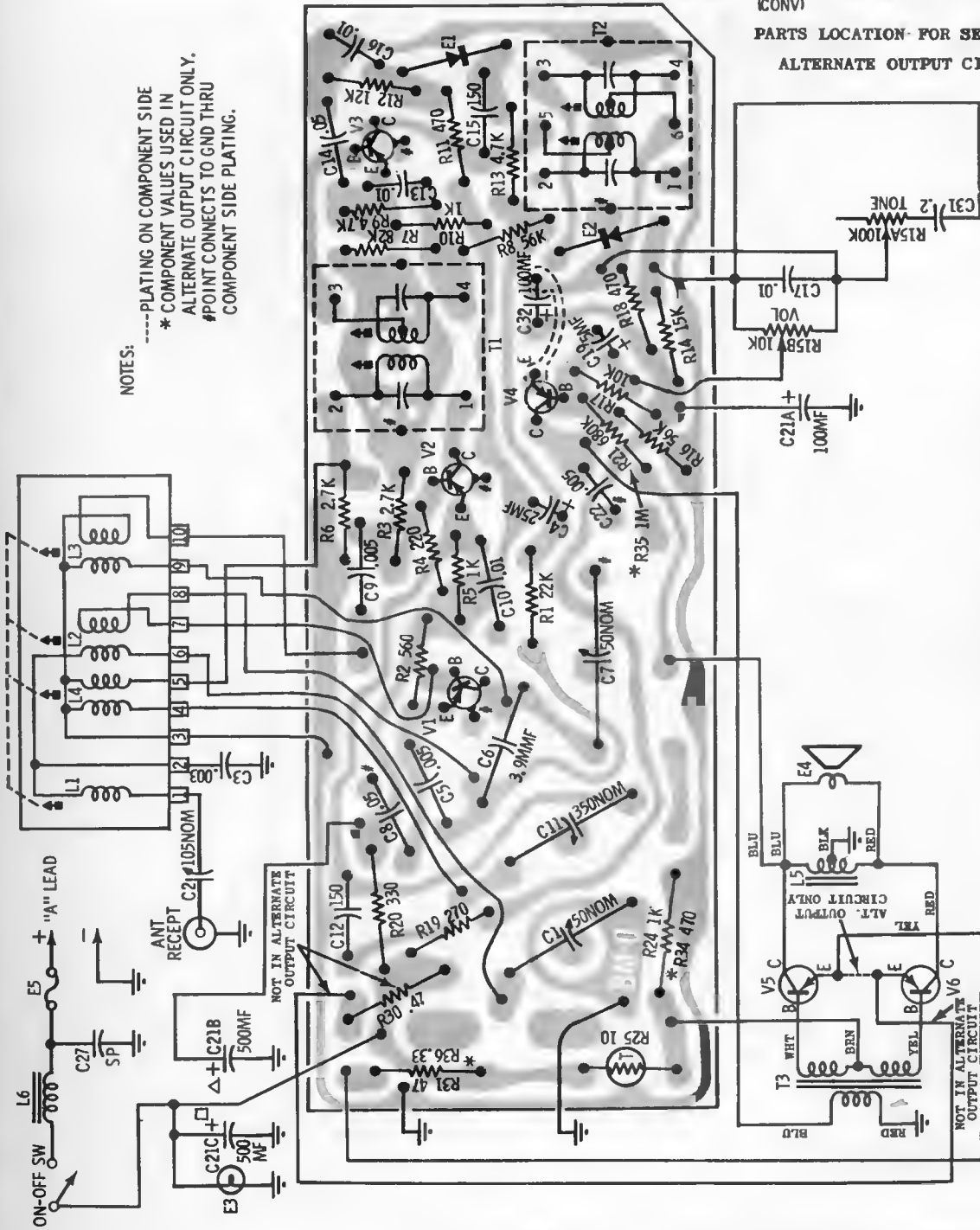

PLATED CHASSIS BOARD WIRING DIAGRAM
 COMPONENTS SHOWN ARE ACTUALLY LOCATED ON OPPOSITE SIDE -
 COMPONENT SIDE PLATING CONTAINS GROUND CONNECTIONS ONLY

MOTOROLA

MOTOROLA FORD
 3TME.....C3GA-18806
 3TMF.....C3AA-18806
 3TMY.....C3YA-18806

(Service material continued on the next page at right)

PLATED CHASSIS BOARD DESCRIPTION - Motorola's PLACIR chassis has plating on both sides of the chassis board. The exposed side contains the actual circuit connections while the plating on the component side of the chassis board provides a convenient chassis B-return for components and circuit wiring. Plating on the component side also provides shielding between the top and bottom of the unit.

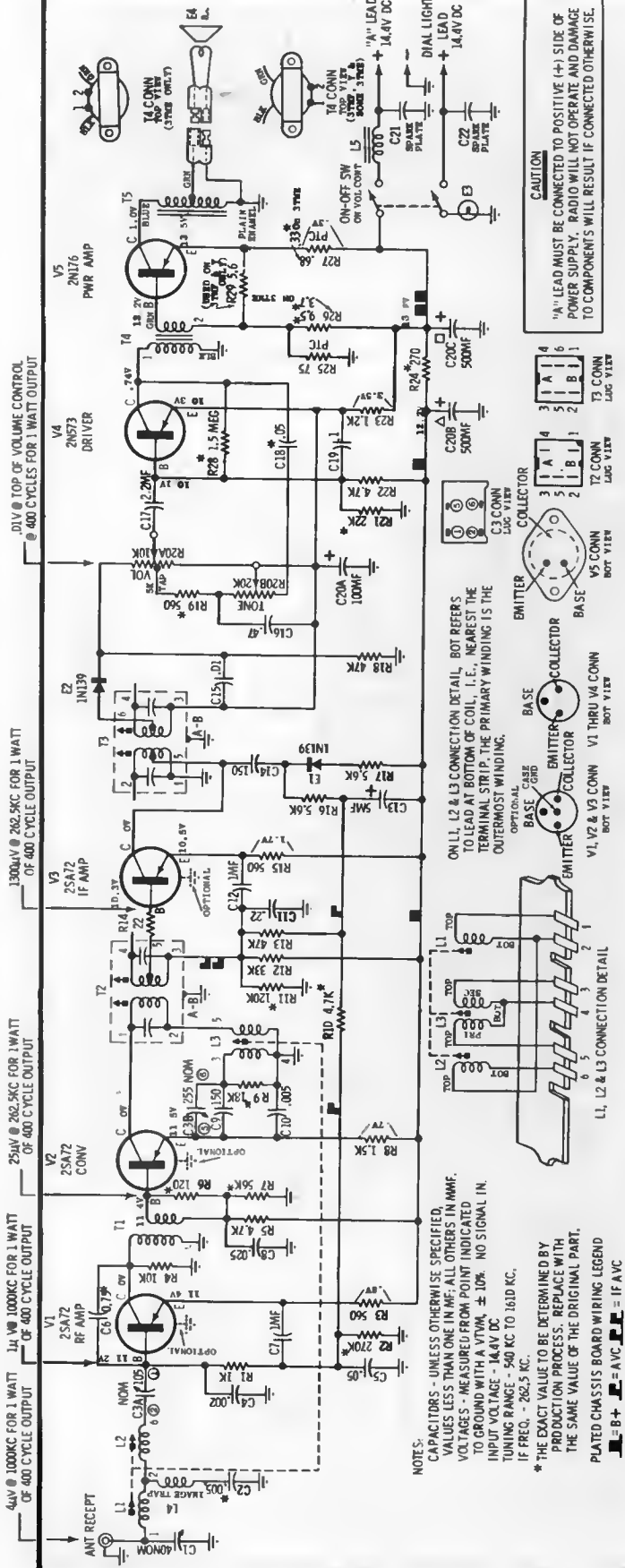

NOTES:
 CAPACITORS - UNLESS OTHERWISE SPECIFIED, VALUES LESS THAN ONE IN MF; ALL OTHERS IN MMF.
 VOLTAGES - MEASURED FROM POINT INDICATED TO GROUND WITH A VTVM, ± 10%. NO SIGNAL IN INPUT VOLTAGE - 14.4V DC.
 TUNING RANGE - 540 KC TO 1610 KC.
 IF FREQ. - 282.5 KC.
 * THE EXACT VALUE TO BE DETERMINED BY PRODUCTION PROCESS. REPLACE WITH THE SAME VALUE OF THE ORIGINAL PART.
 PLATED CHASSIS BOARD WIRING LEGEND
 B+ = B + AVC = IF

CAUTION
 "A" LEAD MUST BE CONNECTED TO POSITIVE (+) SIDE OF POWER SUPPLY. RADIO WILL NOT OPERATE AND DAMAGE TO COMPONENTS WILL RESULT IF CONNECTED OTHERWISE.

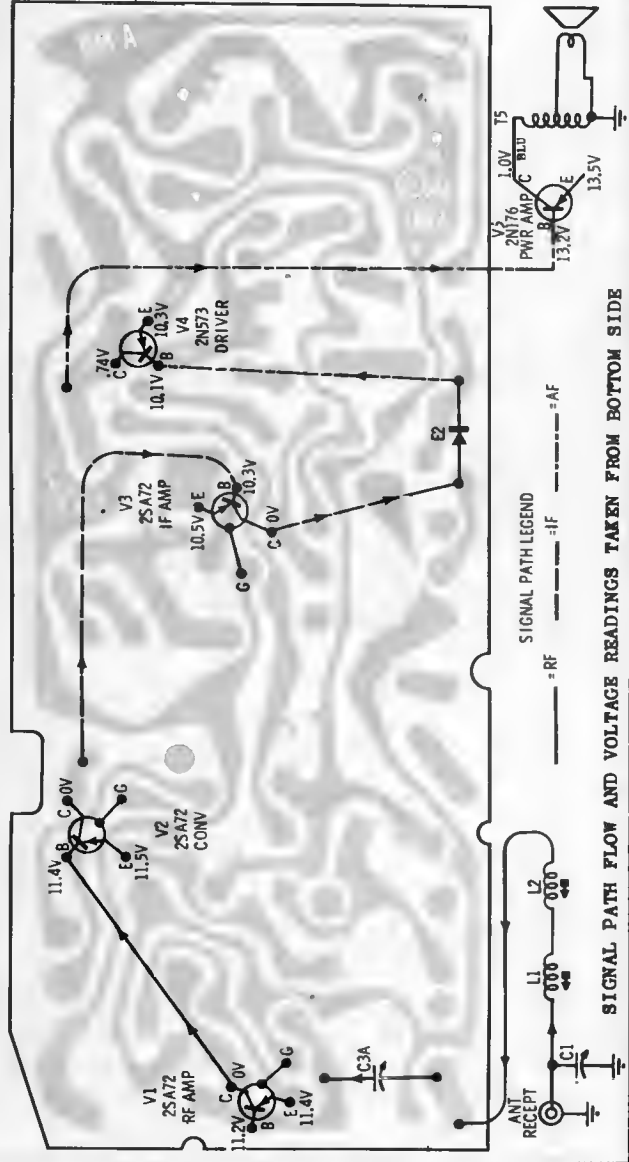

VOLUME R-24, MOST-OFTEN-NEEDED 1964 RADIO SERVICING INFORMATION

MOTOROLA 3TME, 3TMF, 3TMY, Continued from preceding page, at left

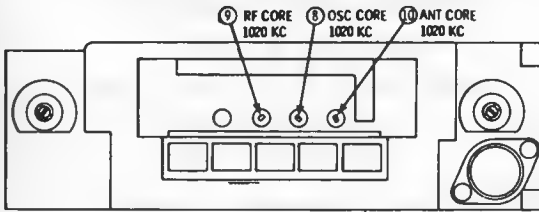

TUNER CORE ADJ SHOWN FROM FRONT OF RADIO

ALIGNMENT POINTS LOCATION DETAIL

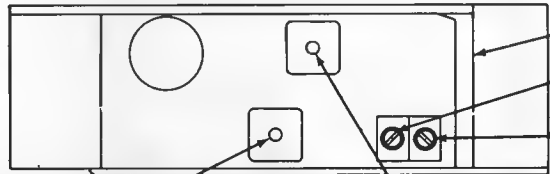

2ND IF TOP 1 262.5 KC BOT 2 IF'S & TRIMMERS SHOWN FROM REAR OF RADIO 1ST IF TOP 3 262.5 KC BOT 2

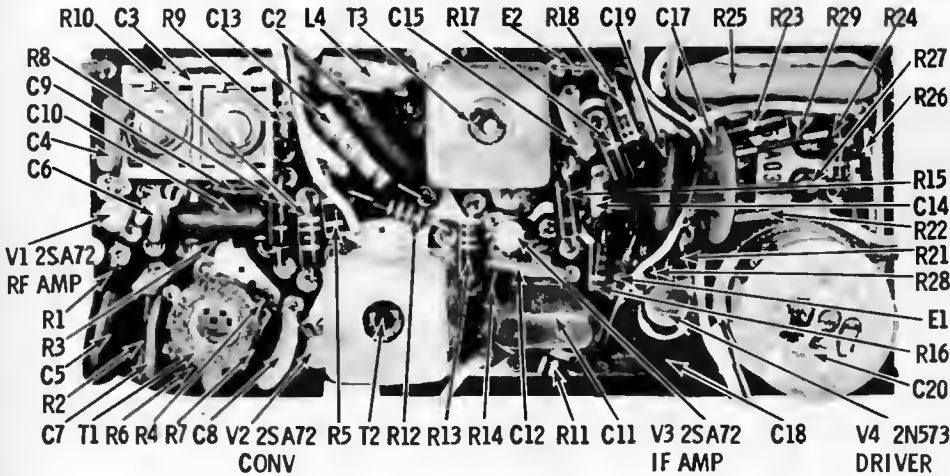

MODELS 3TME, 3TMF & 3TMY PARTS LOCATION

MOTOROLA	FORD
3TME.....	C3GA-18806
3TMF.....	C3AA-18806
3TMY.....	C3YA-18806

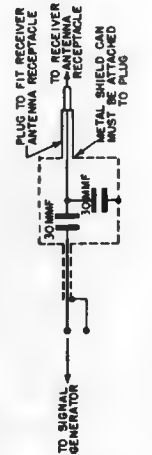

DUMMY ANTENNA

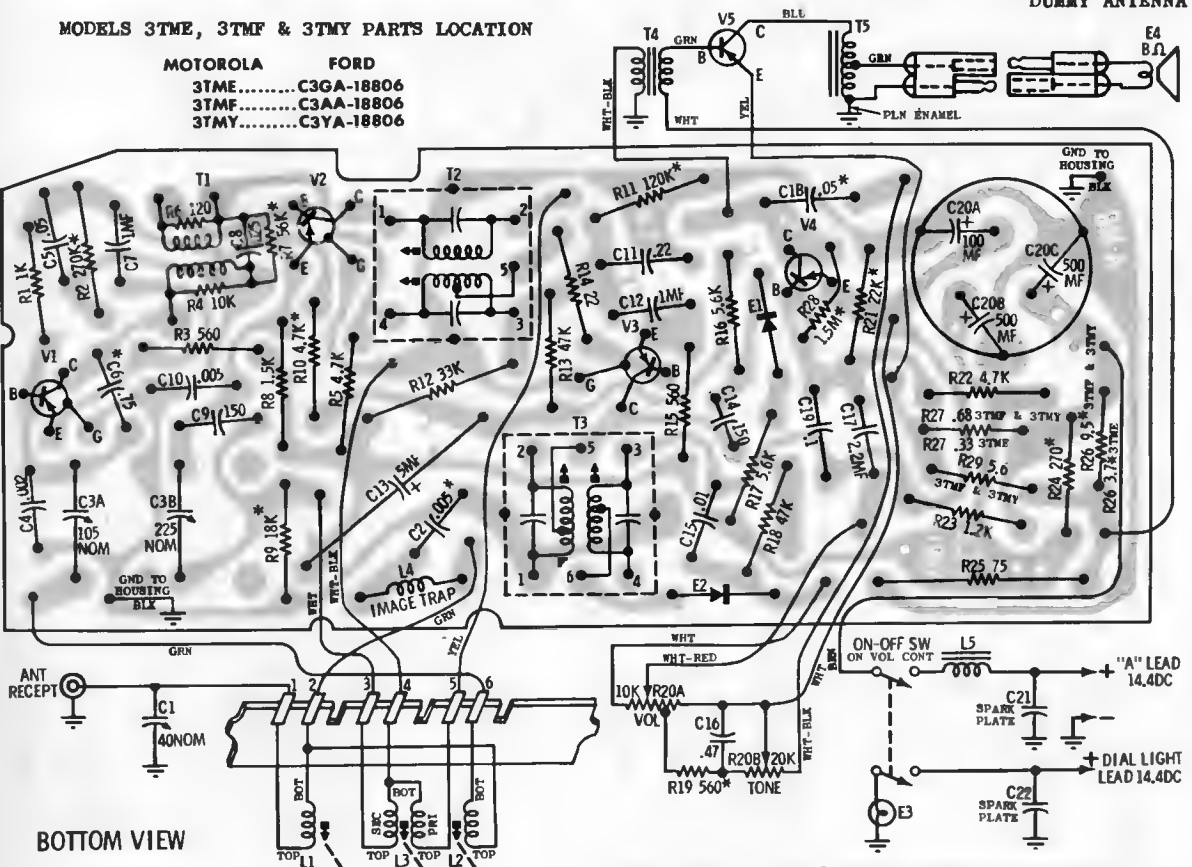

BOTTOM VIEW

MODELS 3TME, 3TMF & 3TMY PLATED BOARD WIRING

COMPONENTS SHOWN ARE ACTUALLY LOCATED ON OPPOSITE SIDE-COMPONENT SIDE OF PLATING CONTAINS GROUND CONNECTIONS ONLY-SEE PLATED CHASSIS BOARD DESCRIPTION

MOTOROLA

MOTOROLA 3TMR

AMERICAN MOTORS 8991142

(Continued on the next page at right)

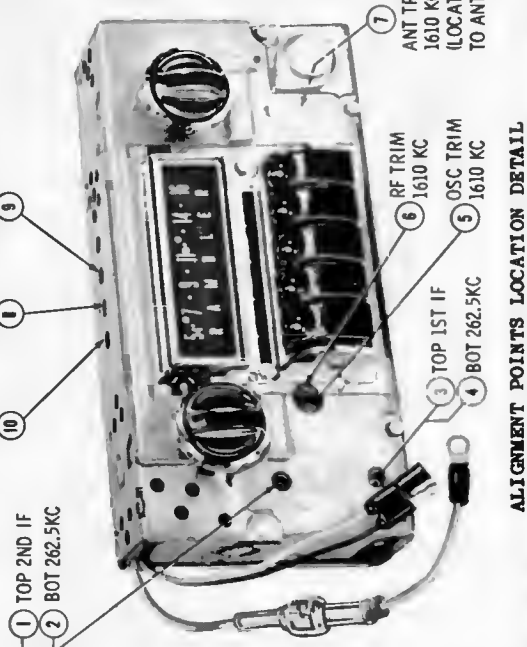
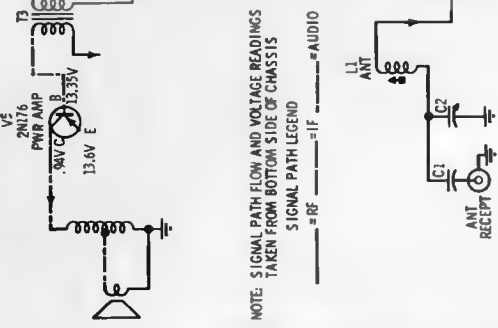
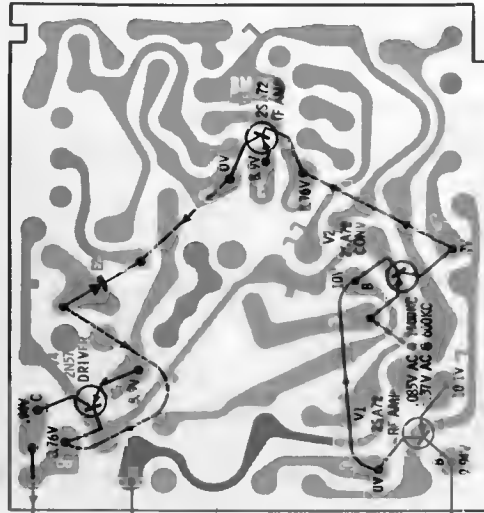
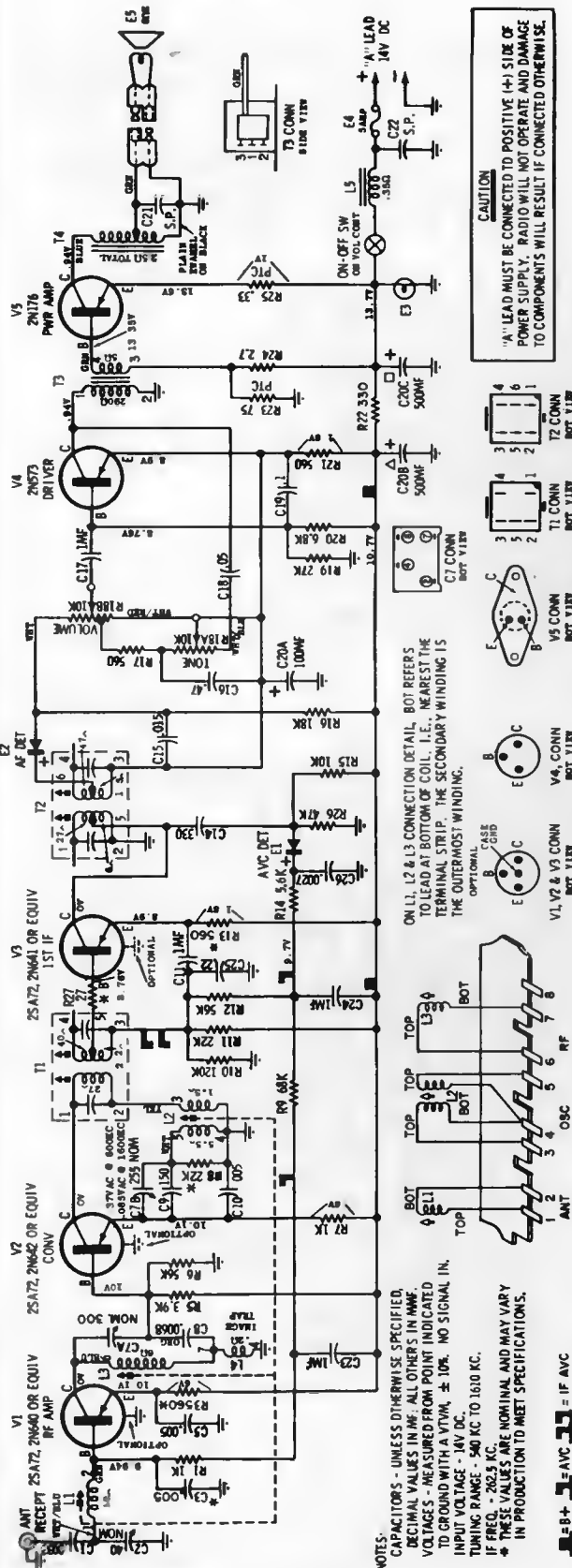

MOTOROLA

MOTOROLA 3TMR AMERICAN MOTORS 8991142

(Continued from preceding page, at left)

retaining brackets and locked in position with the chassis board locking spring. Re-solder ground lead.

TRANSISTOR REPLACEMENT - When replacing a transistor (other than the power transistor), grasp the transistor leads (between transistor body and plated chassis board) with a pair of long nose pliers to prevent excessive heating of transistor body during soldering operation.

TO SET PUSHBUTTONS

Allow receiver to warm up for fifteen minutes. Pull up on push buttons to unlock. Push down firmly on pushbuttons to lock after station has been selected.

wire from chassis housing. Release the chassis board locking spring and carefully lift chassis board out of housing. Position the chassis board vertically with respect to radio housing for servicing.

After servicing is performed, re-install plated chassis board. Make certain chassis board is properly placed in the grooves of the chassis

All B- connections are carried through the placir chassis in multiple paths to the B- side. This insures a good low resistance return path. Two separate and independent paths are provided to ground.

TO SERVICE PLATED CHASSIS BOARD - To remove the plated chassis from the radio housing, unsolder the plated chassis ground

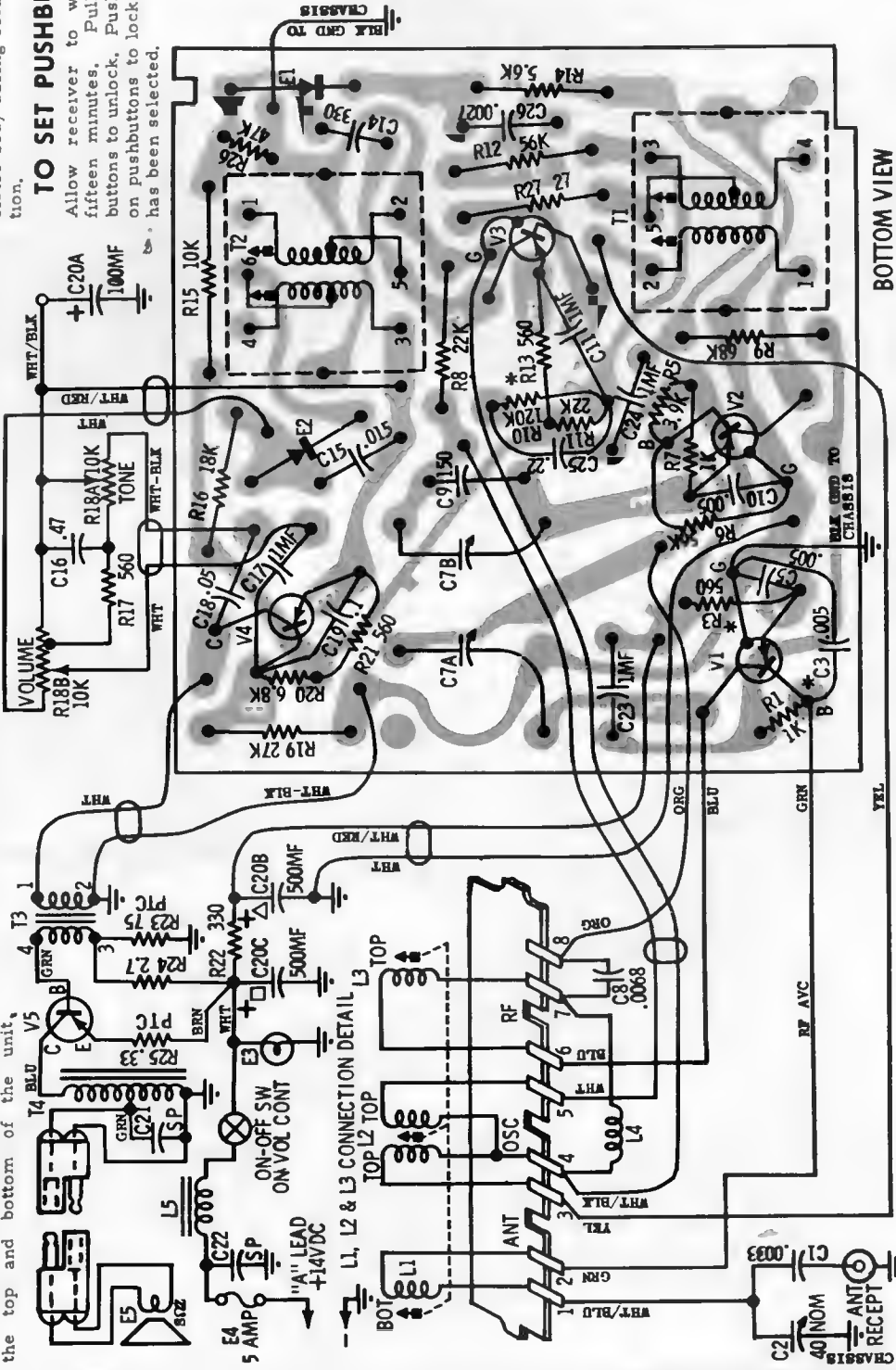

COMPONENTS SHOWN ARE ACTUALLY LOCATED ON OPPOSITE SIDE - COMPONENT SIDE OF PLATING CONTAINS GROUND CONNECTIONS ONLY - SEE PLATED CHASSIS BOARD DESCRIPTION

MOTOROLA

Models CA63 and CRA63

This material is also applicable to Models CYA63 and OEA63 which are practically identical.

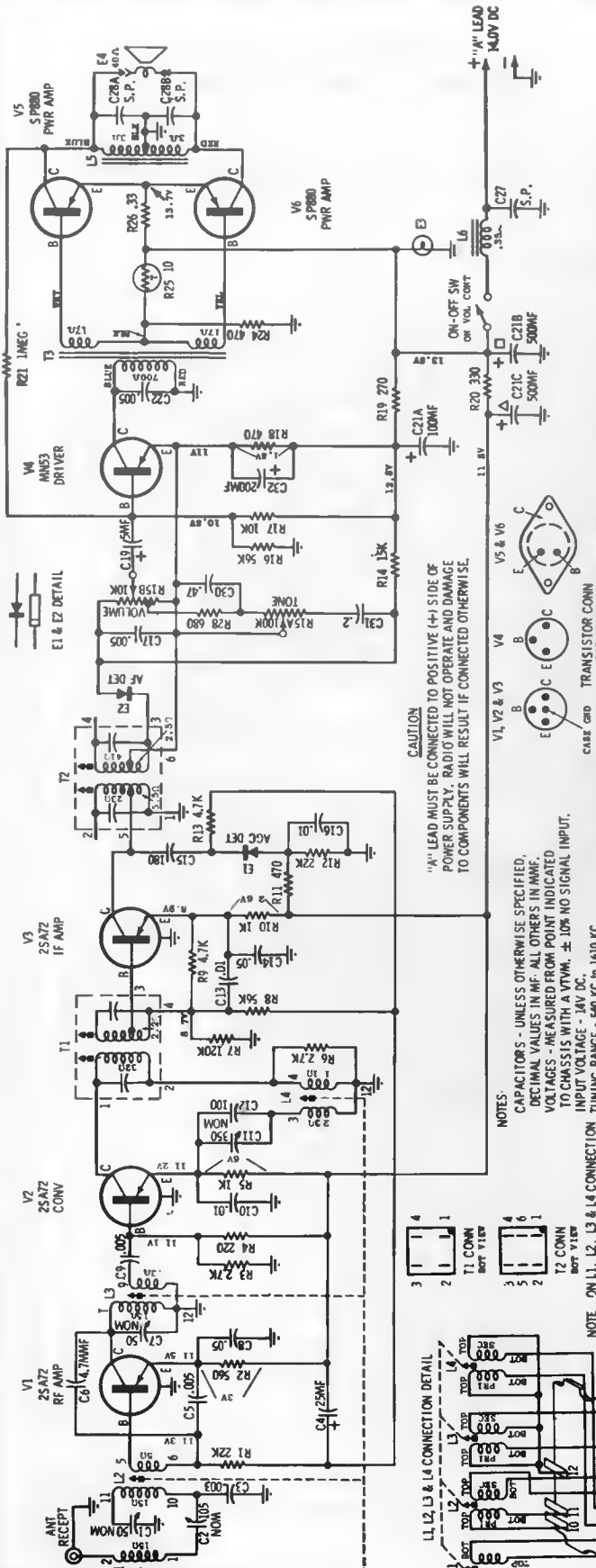

CAUTION
 "A" LEAD MUST BE CONNECTED TO POSITIVE (+) SIDE OF POWER SUPPLY. RADIO WILL NOT OPERATE AND DAMAGE TO COMPONENTS WILL RESULT IF CONNECTED OTHERWISE.

NOTES:
 CAPACITORS - UNLESS OTHERWISE SPECIFIED, DECIMAL VALUES IN MF, ALL OTHERS IN MMF. VOLTAGES - MEASURED FROM POINT INDICATED TO CHASSIS WITH A VTVM, ± 10% NO SIGNAL INPUT. INPUT VOLTAGE - 14V DC. TUNING RANGE - 540 KC TO 1610 KC.

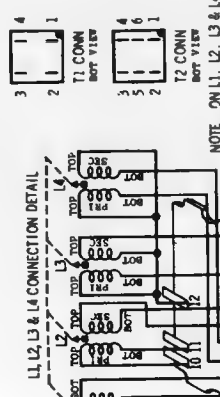

NOTE: ON L1, L2, L3 & L4 CONNECTION DETAIL, BOT REFERS TO LEAD AT BOTTOM OF COIL, I. E., NEAREST THE TERMINAL STRIP. THE SECONDARY WINDING IS THE OUTERMOST WINDING.

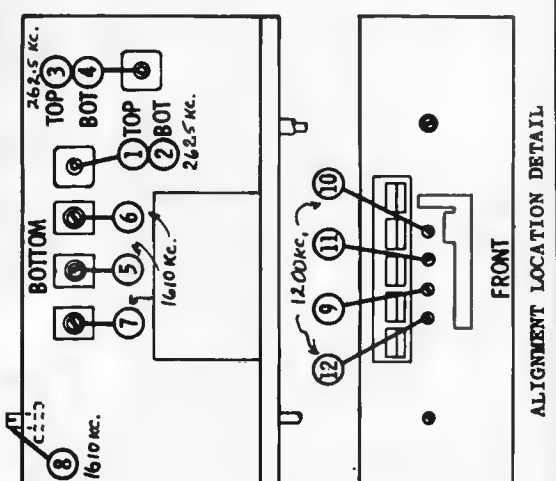
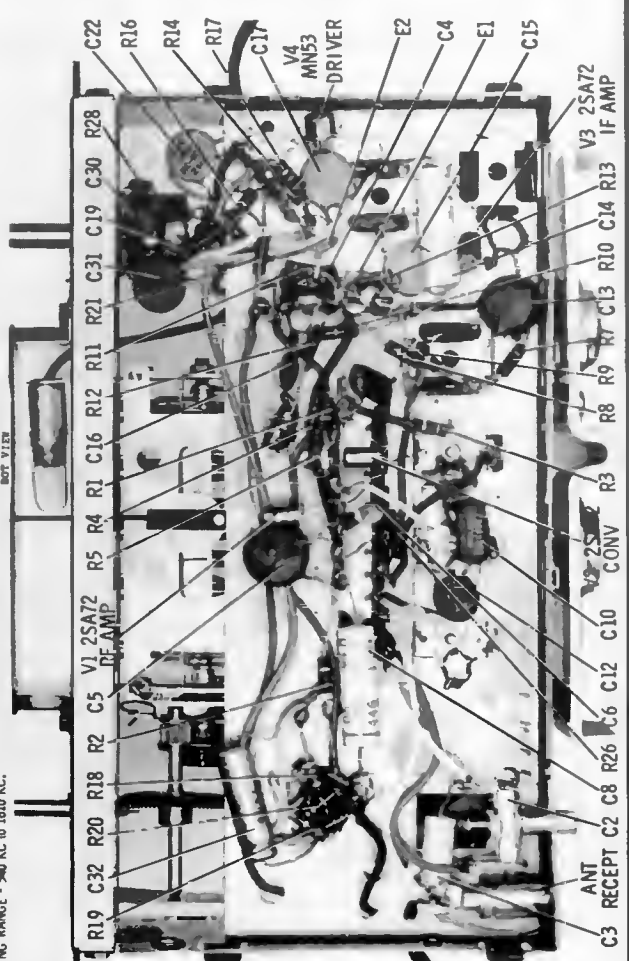

MOTOROLA

auto radio CRM63, CYM63

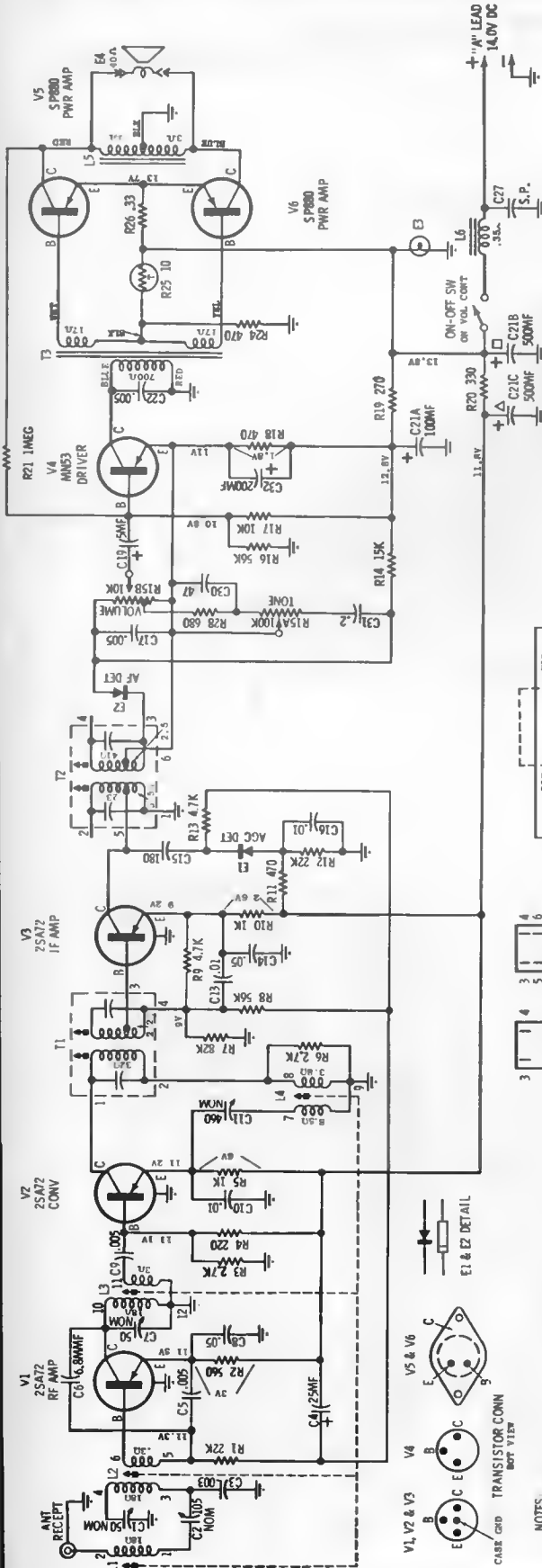

CAUTION
 A" LEAD MUST BE CONNECTED TO POSITIVE (+) SIDE OF POWER SUPPLY. RADIO WILL NOT OPERATE AND DAMAGE TO COMPONENTS WILL RESULT IF CONNECTED OTHERWISE.

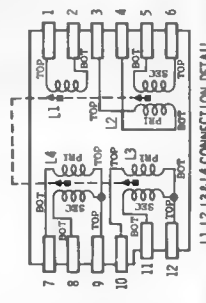

NOTE: ON L1, L2, L3 & L4 CONNECTION DETAIL, BOT REFERS TO LEAD AT BOTTOM OF COIL, I.E., NEAREST THE TERMINAL STRIP. THE SECONDARY WINDING IS THE OUTERMOST WINDING.

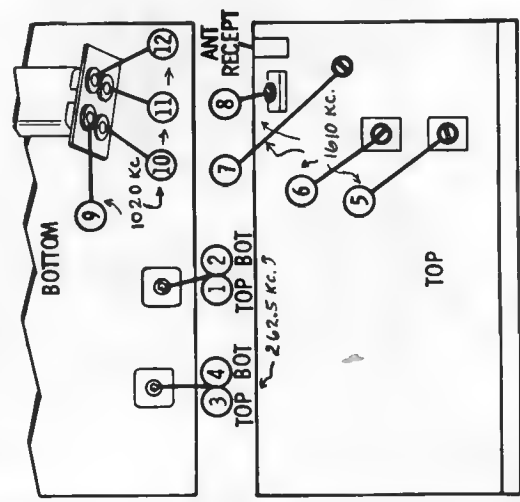
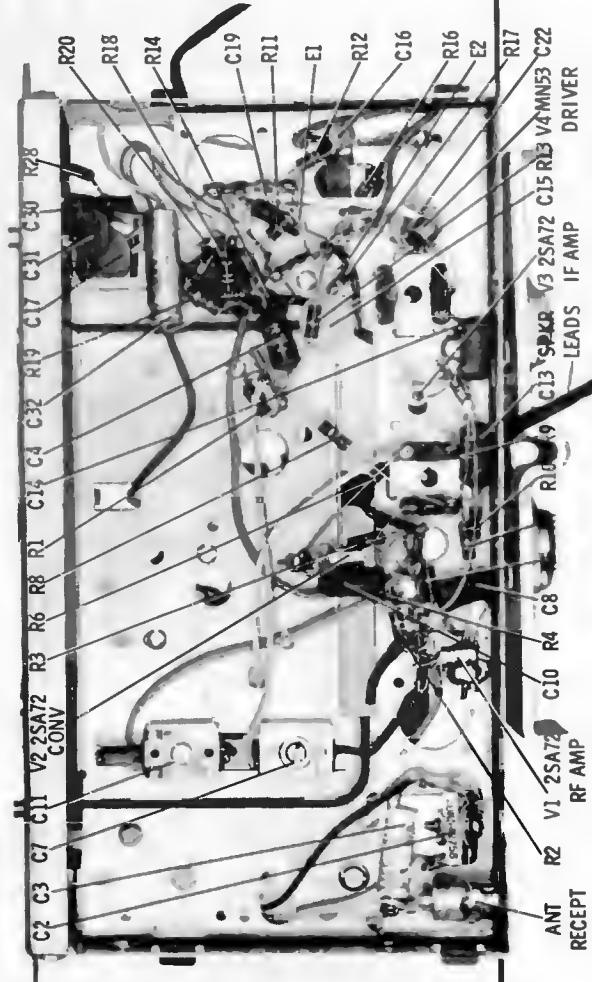

NOTES:
 CAPACITORS - UNLESS OTHERWISE SPECIFIED, DECIMAL VALUES IN MF. ALL OTHERS IN MMF.
 VOLTAGES - MEASURED FROM POINT INDICATED TO CHASSIS WITH A VTVM, ±10% NO SIGNAL INPUT.
 INPUT VOLTAGE - 14V DC.
 TUNING RANGE - 540 KC TO 1610 KC.
 IF FREQ. - 262.5 KC

MOTOROLA

auto radio VWM63

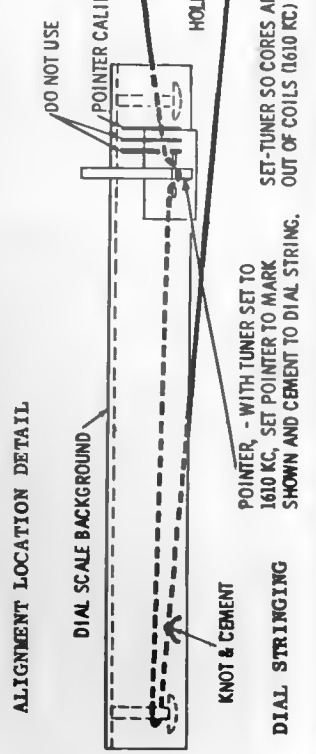
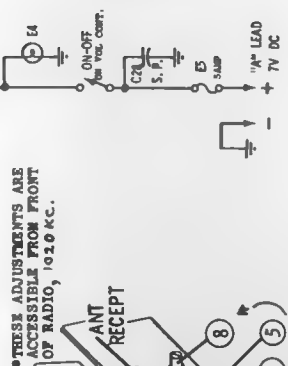
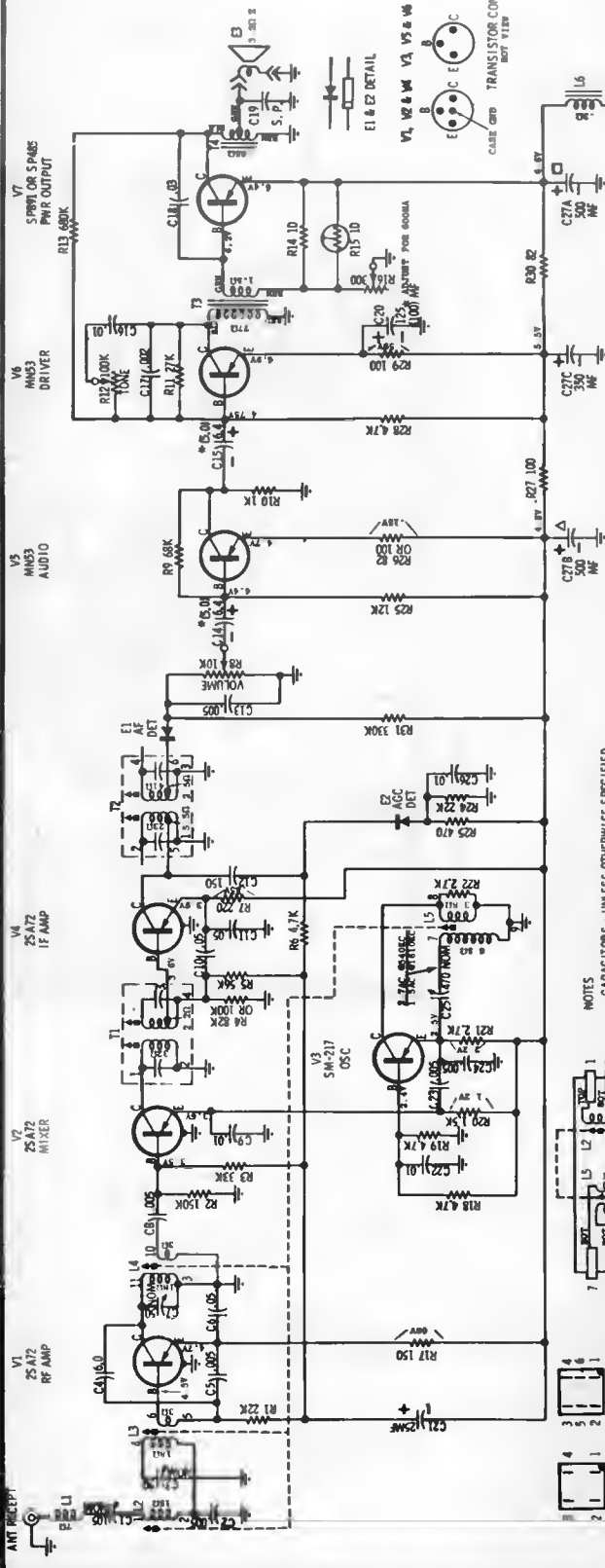

NOTES
CAPACITORS - UNLESS OTHERWISE SPECIFIED, DECIMAL VALUES IN MF, ALL OTHERS IN MMF. VOLTAGES - MEASURED FROM POINT INDICATED TO CHASSIS WITH A VTVM, $\pm 10\%$ NO SIGNAL INPUT. INPUT VOLTAGE - 7.0VDC. TUNING RANGE - 540 KC TO 1610 KC. IF FREQ. - 282.5 KC.

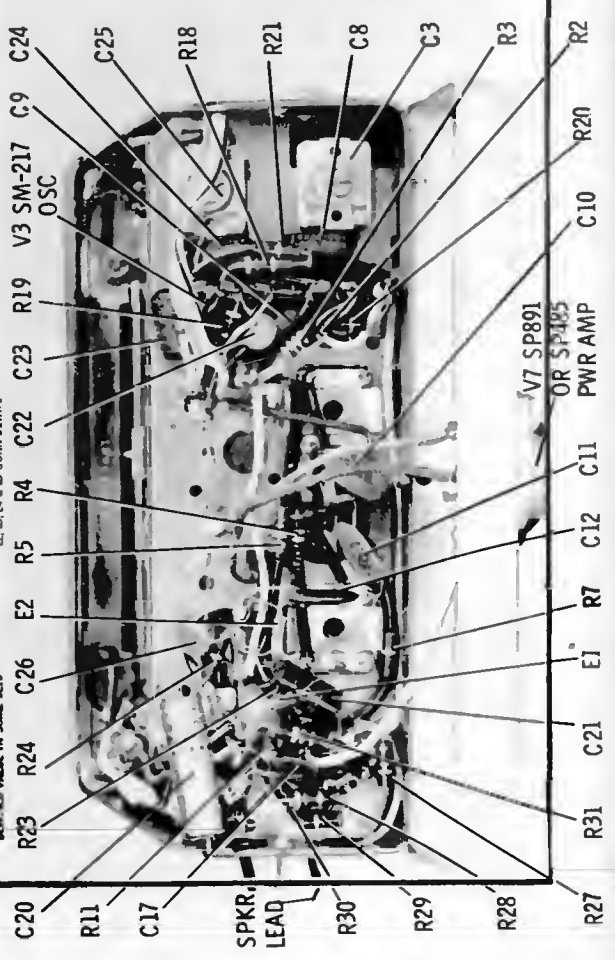
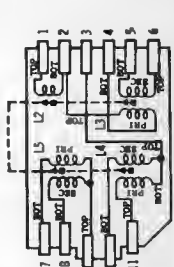

MOTOROLA

auto radio VWA63

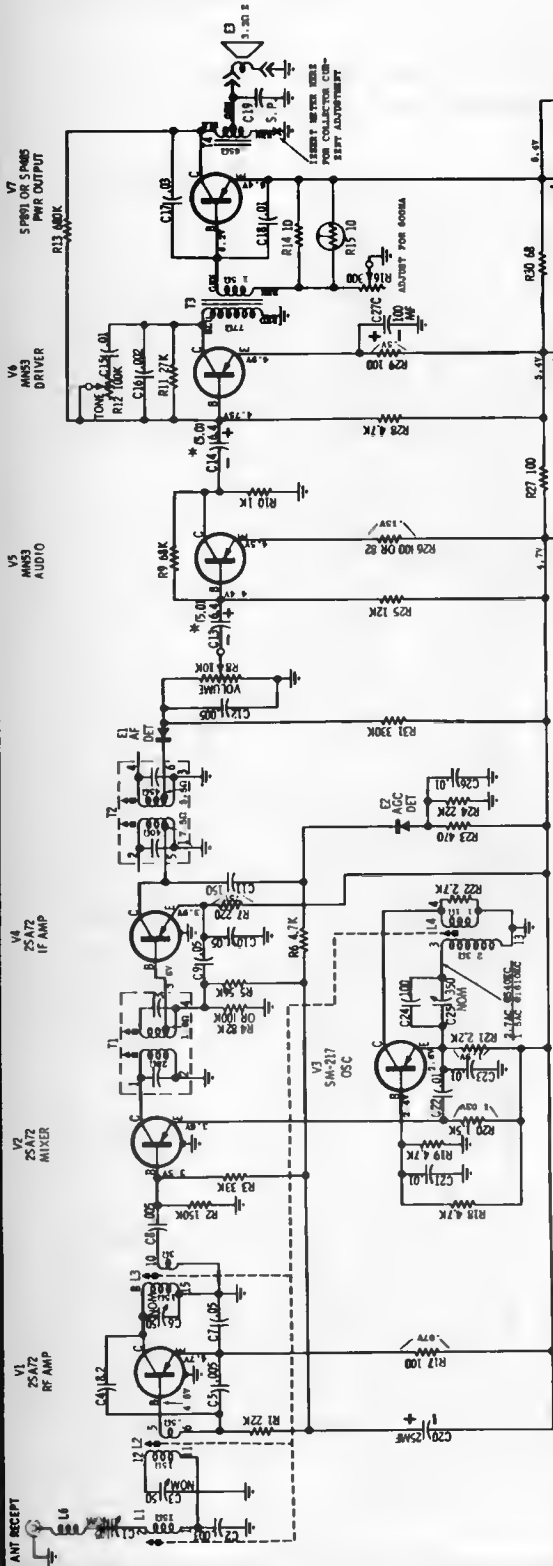

NOTES
 CAPACITORS - UNLESS OTHERWISE SPECIFIED, DECIMAL VALUES IN MF, ALL OTHERS IN MMF.
 VOLTAGES - MEASURED FROM POINT INDICATED TO CHASSIS WITH A VTVM, ± 10% NO SIGNAL INPUT.
 INPUT VOLTAGE - 1.0VDC
 TUNING RANGE - 540 KC TO 1618 KC.
 IF FREQ. - 262.5 KC

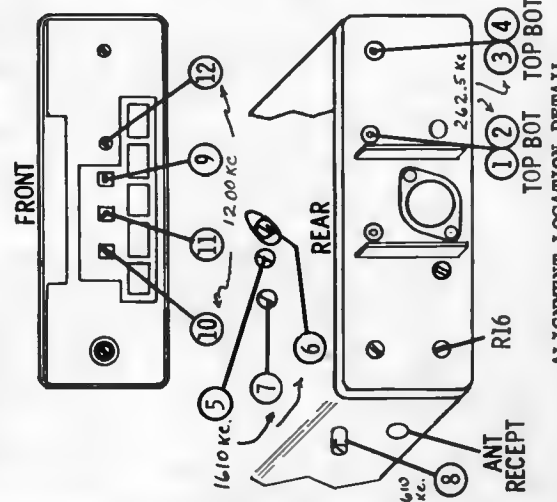
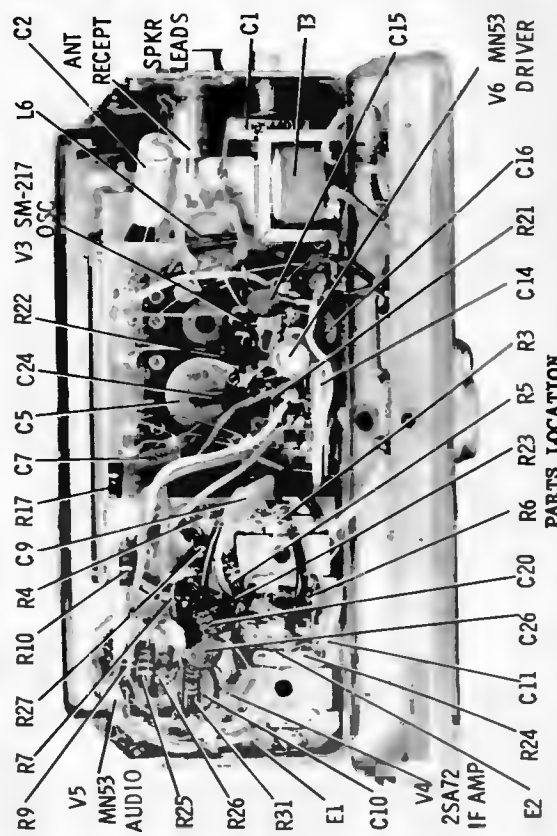
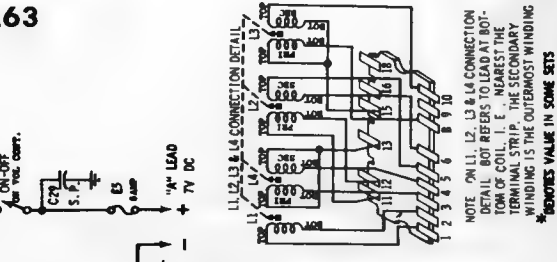
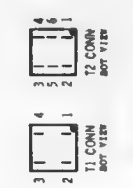
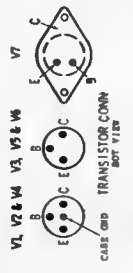

PARTS LOCATION
 ALIGNMENT LOCATION DETAIL

MOTOROLA

auto radio

MOPAR 216,217,337,339,344,345

(Diagrams and service data on the next three pages, alignment on page following; total 4 pages of data)

PLATED CHASSIS BOARD DESCRIPTION

Motorola's PLAcir chassis has plating on both sides of the chassis board. The exposed side contains the actual circuit connections while the plating on the component side provides a convenient chassis B-return for components and circuit wiring. Plating on the component side also provides shielding between the top and bottom of the unit similar to a metal chassis which incorporates hand wiring.

All B-connections are carried through the PLAcir chassis in multiple paths to the B-side. This insures a good low resistance return path.

PLATED CHASSIS BOARD REMOVAL

To remove the plated chassis completely from the radio housing, unsolder the plated chassis mounting bracket, bend the ears straight and carefully remove the bracket from chassis board. Lift plated board until its tabs are free; carefully remove from housing.

After servicing is performed, re-install plated chassis board, engaging 4 board tabs into slots in housing; then attach plated chassis mounting bracket into place. It is important, at this point, that the following leads are dressed correctly.

- A. Make certain the pilot light leads and transistor leads are dressed above the pilot light socket; do not allow them to lie between the pilot light and light shield.
- B. Dress volume control leads away from filter choke.
- C. Dress antenna lead along edge of plated chassis as far away from oscillator and RF trimmer as possible.

TRANSISTOR REPLACEMENT

When replacing a transistor (other than a power transistor), grasp the transistor leads (between transistor body and plated chassis board) with a pair of long nose pliers to prevent excessive heating of transistor body during soldering operation.

TO SET PUSHBUTTONS

Allow receiver to warm up for fifteen minutes. Pull out on pushbutton to unlock. Push pushbutton in firmly to lock after station has been selected.

CAUTION
"A" LEAD MUST BE CONNECTED TO POSITIVE (+) SIDE OF POWER SUPPLY. RADIO WILL NOT OPERATE AND DAMAGE TO COMPONENTS WILL RESULT IF CONNECTED OTHERWISE

NOTES:
CAPACITORS - UNLESS OTHERWISE SPECIFIED, DECIMAL VALUES IN IF FREQ. - 262.5 KC. VOLTAGES - MEASURED FROM POINT INDICATED TO GROUND WITH A VTVM, $\pm 10\%$ NO SIGNAL IN. MEET SPECIFICATIONS.

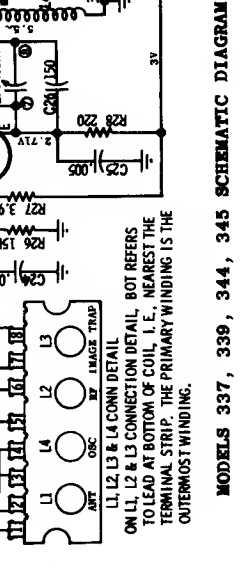
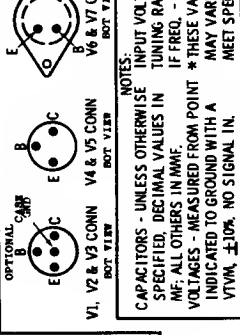

MODELS 337, 339, 344, 345 SCHEMATIC DIAGRAM

MOTOROLA Models 216, 217, 337, 339, 344, 345

(Continued from preceding page, other service data and alignment on the next two pages)

Models 337, 339, 344, 345,
Plated Chassis Board Wiring.
(See note at bottom, at right)

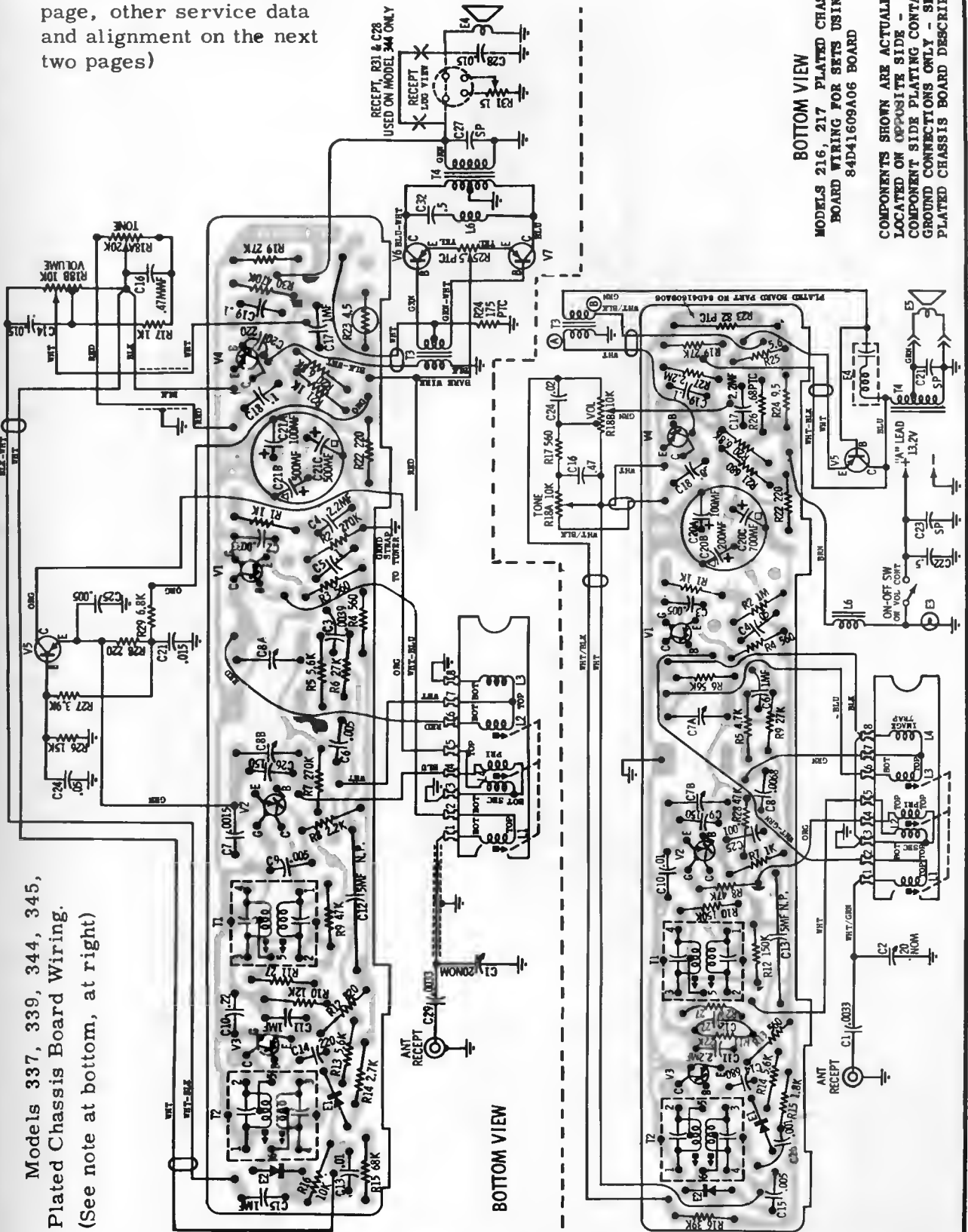

BOTTOM VIEW
MODELS 216, 217 PLATED CHASSIS BOARD WIRING FOR SETS USING 84D41609A06 BOARD
COMPONENTS SHOWN ARE ACTUALLY LOCATED ON OPPOSITE SIDE - COMPONENT SIDE PLATING CONTAINS GROUND CONNECTIONS ONLY - SEE PLATED CHASSIS BOARD DESCRIPTION

BOTTOM VIEW

MOTOROLA Models 216, 217,
337, 339, 344, 345

(Continued)

BOTTOM VIEW
MODELS 216, 217 PLATED CHASSIS
BOARD WIRING FOR SETS USING
84D41609A05 BOARD

COMPONENTS SHOWN ARE ACTUALLY
LOCATED ON OPPOSITE SIDE -
COMPONENT SIDE PLATING CONTAINS
GROUND CONNECTIONS ONLY - SEE
PLATED CHASSIS BOARD DESCRIPTION

MODELS 216, 217 SCHEMATIC DIAGRAM

CAUTION
"A" LEAD MUST BE CONNECTED TO POSITIVE (+) SIDE OF
POWER SUPPLY. RADIO WILL NOT OPERATE AND DAMAGE
TO COMPONENTS WILL RESULT IF CONNECTED OTHERWISE.

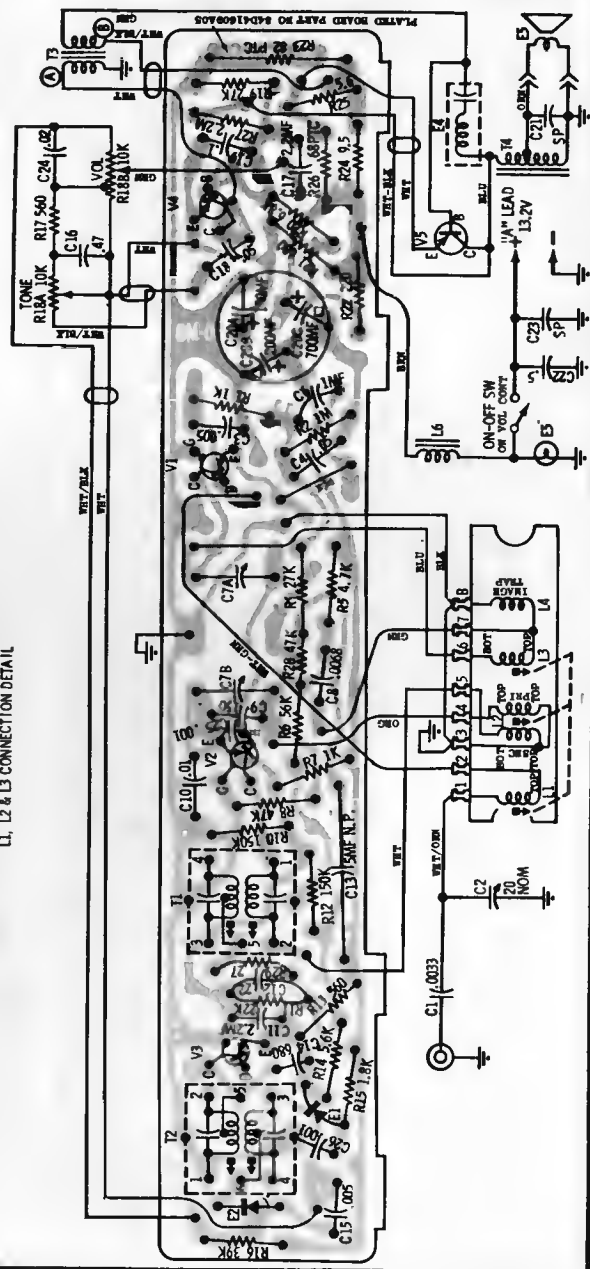
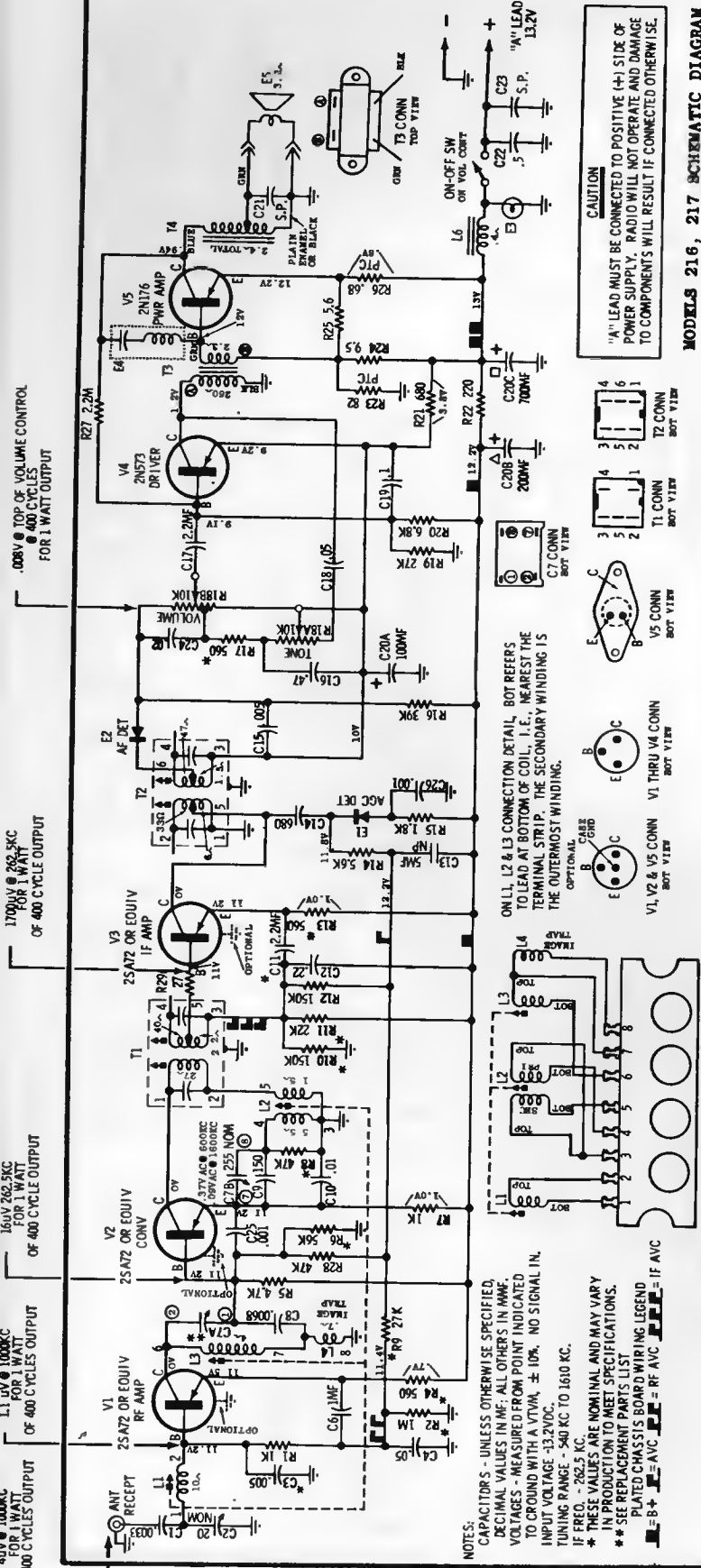

VOLUME R-24, MOST-OFTEN-NEEDED 1964 RADIO SERVICING INFORMATION

MOTOROLA Models 216, 217, 337, 339, 344, 345, Alignment Data, Continued

ALIGNMENT

Connect an output meter across the speaker voice coil. Set volume to maximum and tone to high. Attenuate signal generator output to maintain 1.79 volts on output meter at all times to prevent overloading the receiver.

STEP	GENERATOR CONNECTION	GENERATOR FREQUENCY (400 cycle mod)	TUNER SET TO	ADJUST	REMARKS
IF ALIGNMENT					
1.	Ant recept thru .1 mf capacitor & ground	262.5 Kc	Hi end stop	1, 2, 3 & 4	Adjust for maximum.
RF ALIGNMENT					
2.	Ant recept thru dummy antenna (see Figure)	1610 Kc	Hi end stop	5, 6 & 7	Adjust for maximum.
NOTE: Do not perform steps 3, 4, 5 & 6 unless the tuner has been tampered with or components have been replaced. Before proceeding with step 3, back tuning cores (of ant, RF & osc only) out of coils to eliminate their effect on the trimmer adjustments.					
3.	Ant recept thru dummy antenna (see Figure)	1610 Kc	Hi end stop	5, 6 & 7	Adjust for maximum.
4.	"	1020 Kc	Tuner carriage 9/16" in from hi end stop	8, 9 & 10	Adjust for maximum, using alignment tool Motorola Part No. 66A76278.
5.	"	1610 Kc	Hi end stop	5, 6 & 7	Adjust for maximum.
6.	Repeat steps 4 & 5 until no further increase, then cement cores in place.				Step 5 should be last step.
ANTENNA TRIMMER					
7.			Weak station around 1400 Kc	7	With radio installed in car and antenna fully extended, peak antenna trimmer for maximum.

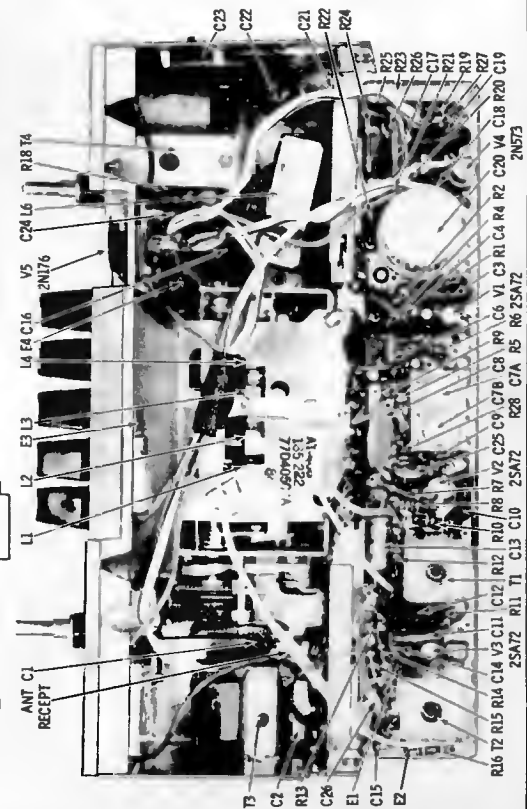
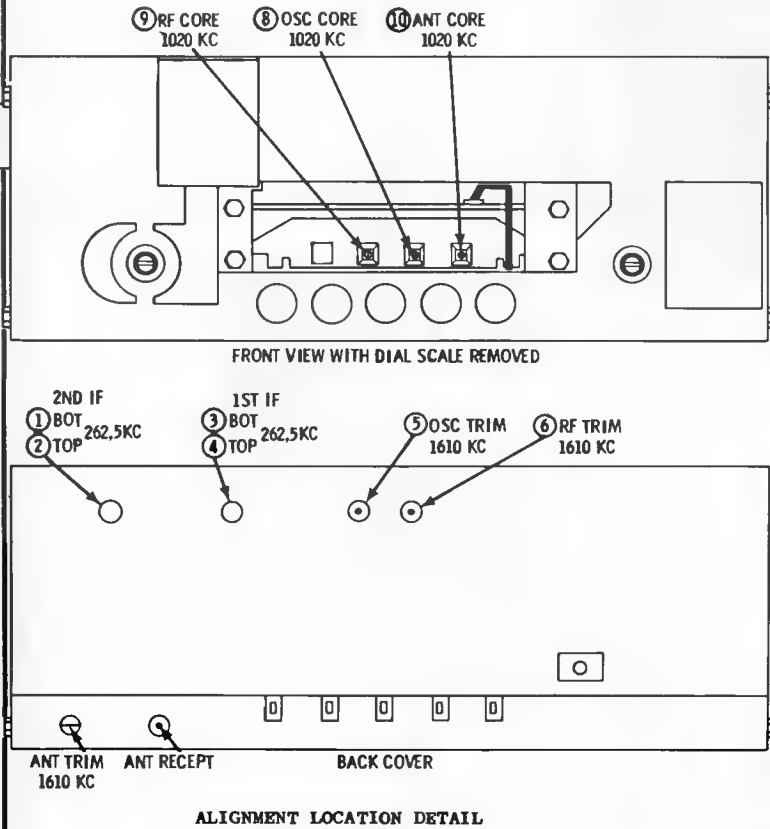
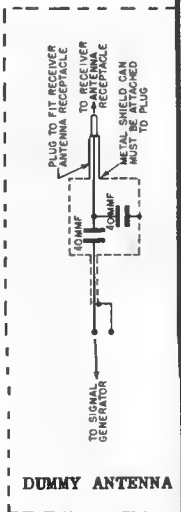

MOTOROLA

Auto Radio Model 290T

(Continued on the next page, at right)

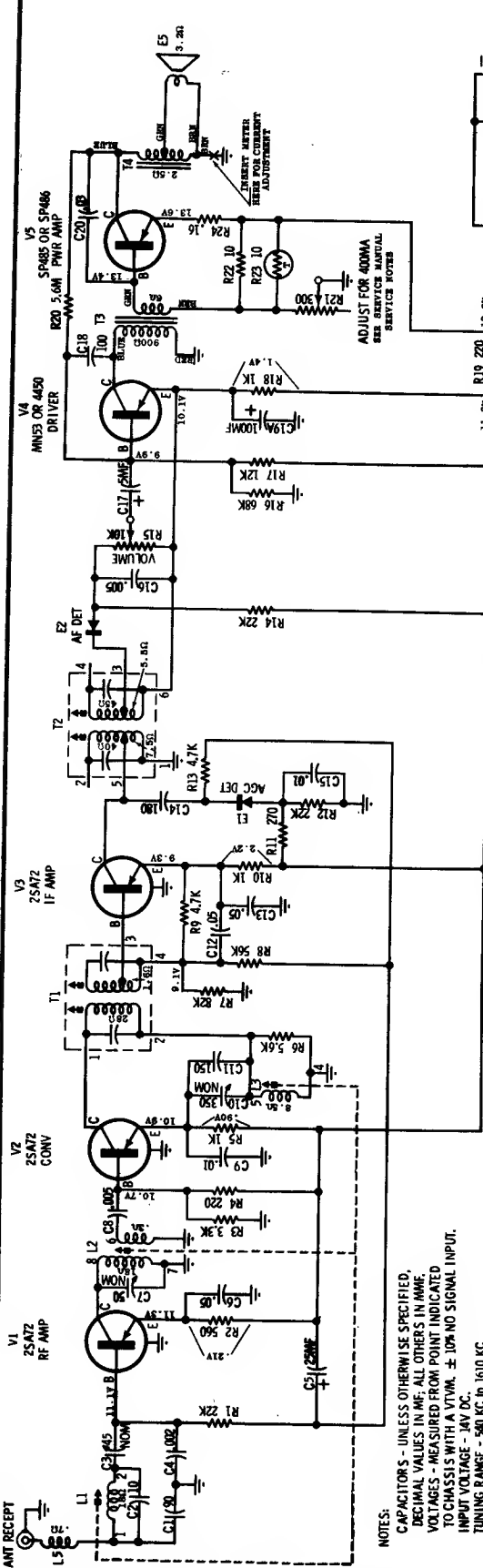

*THESE ADJUSTMENT POINTS ARE ACCESSIBLE FROM FRONT OF RADIO (SEE SERVICE NOTES)

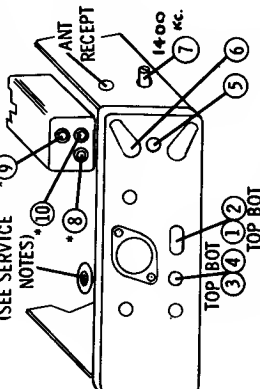

ALIGNMENT LOCATION DETAIL

NOTE: ON L1, L2 & L3 CONNECTION DETAIL BOT REFERS TO LEAD AT BOTTOM OF COIL, I.E., NEAREST THE TERMINAL STRIP. THE SECONDARY WINDING IS THE OUTERMOST WINDING.

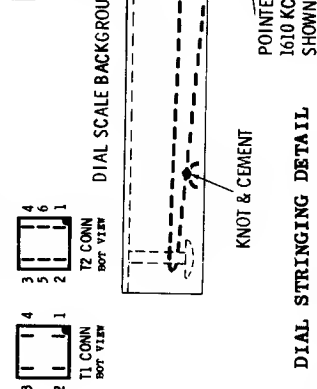

NOTES:
CAPACITORS - UNLESS OTHERWISE SPECIFIED, DECIMAL VALUES IN MF; ALL OTHERS IN MMF.
VOLTAGES - MEASURED FROM POINT INDICATED TO CHASSIS WITH A VTVM, ± 10% NO SIGNAL INPUT.
INPUT VOLTAGE - 14V DC.
TUNING RANGE - 540 KC TO 1610 KC.
IF FREQ. - 262.5 KC

POWER TRANSISTOR CURRENT ADJUSTMENT: After replacing a power transistor, the collector current should be checked and adjusted for proper operation.

A. Insert a low range (0-1 or 0-2 amp) DC ammeter in the primary ground return lead of the output transformer (T-4). Connect the negative terminal of the meter to ground. CAUTION: Be sure the speaker ground lead is connected in common with the transformer common lead to the positive terminal (See SCHEMATIC DIAGRAM).

B. Turn the radio on and allow it to heat up for about 15 minutes.

C. Adjust the bias control (R-21) for a reading of 320 ma with 12.6 volts input to the radio "A" lead.

NOTE: Two values of radio input voltage are given as a convenience to service personnel in order to accommodate different power sources. The current value stated on the schematic diagram is for 14 volts input to the radio "A" lead.

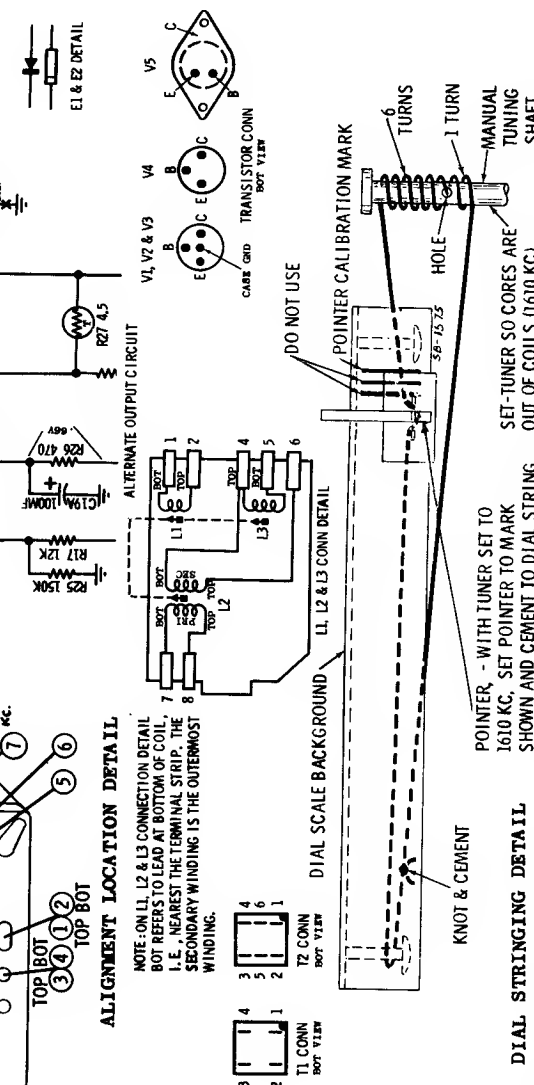

DO NOT USE
POINTER CALIBRATION MARK
HOLE
6 TURNS
1 TURN
MANUAL TUNING SHAFT
SET-TUNER SO CORES ARE OUT OF COILS (1610 KC)
DIAL STRINGING DETAIL
DIAL SCALE BACKGROUND L1, L2 & L3 CONN DETAIL
T2 CONN BOT VIEW
T1 CONN BOT VIEW
KNOT & CEMENT
POINTER - WITH TUNER SET TO 1610 KC, SET POINTER TO MARK SHOWN AND CEMENT TO DIAL STRING.

MOTOROLA Auto Radio Model 290T (Continued from preceding page)

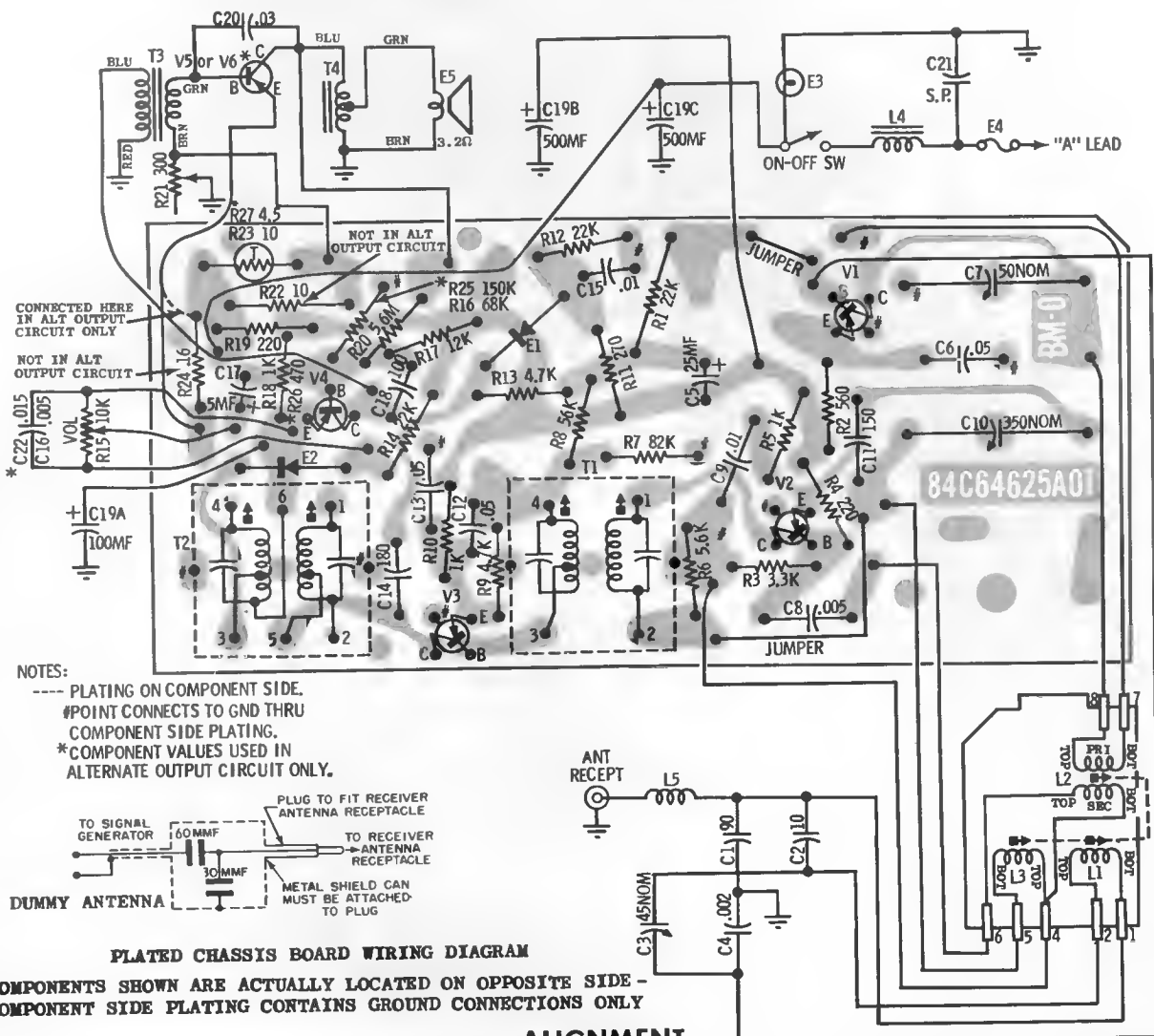

NOTES:

- PLATING ON COMPONENT SIDE.
- # POINT CONNECTS TO GND THRU COMPONENT SIDE PLATING.
- * COMPONENT VALUES USED IN ALTERNATE OUTPUT CIRCUIT ONLY.

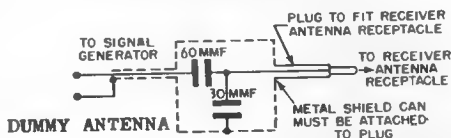

PLATED CHASSIS BOARD WIRING DIAGRAM

COMPONENTS SHOWN ARE ACTUALLY LOCATED ON OPPOSITE SIDE - COMPONENT SIDE PLATING CONTAINS GROUND CONNECTIONS ONLY

ALIGNMENT

Connect an output meter across the speaker voice coil. Set volume to maximum. Attenuate signal generator output to maintain 1 watt (1.79 volts across a 3.2 ohm load) on output meter at all times.

STEP	GENERATOR CONNECTION	GEN FREQ (400 cycle 30% mod)	TUNER SET TO	ADJUST	REMARKS
1.	To collector of RF amp thru .1mf & chassis	262.5Kc	Hi end stop	1, 2, 3 & 4	Adjust for maximum
2.	Ant recept thru dummy (see figure)	1610Kc	Hi end stop	5, 6 & 7	Adjust for maximum
3.	Ant recept thru dummy (see figure)	1610Kc	Hi end stop	5, 6 & 7	Adjust for maximum
4.	"	1020Kc	Tuner carriage .298" from Hi end stop	8, 9 & 10	Adjust for maximum
5.	"	1610Kc	Hi end stop	5, 6 & 7	Adjust for maximum
6.	Repeat steps 4 and 5 until no further increase; step 5 should be last step. Then, cement core screws in place.				

MOTOROLA

Auto Radio Model 323T

(Continued on next page, at right)

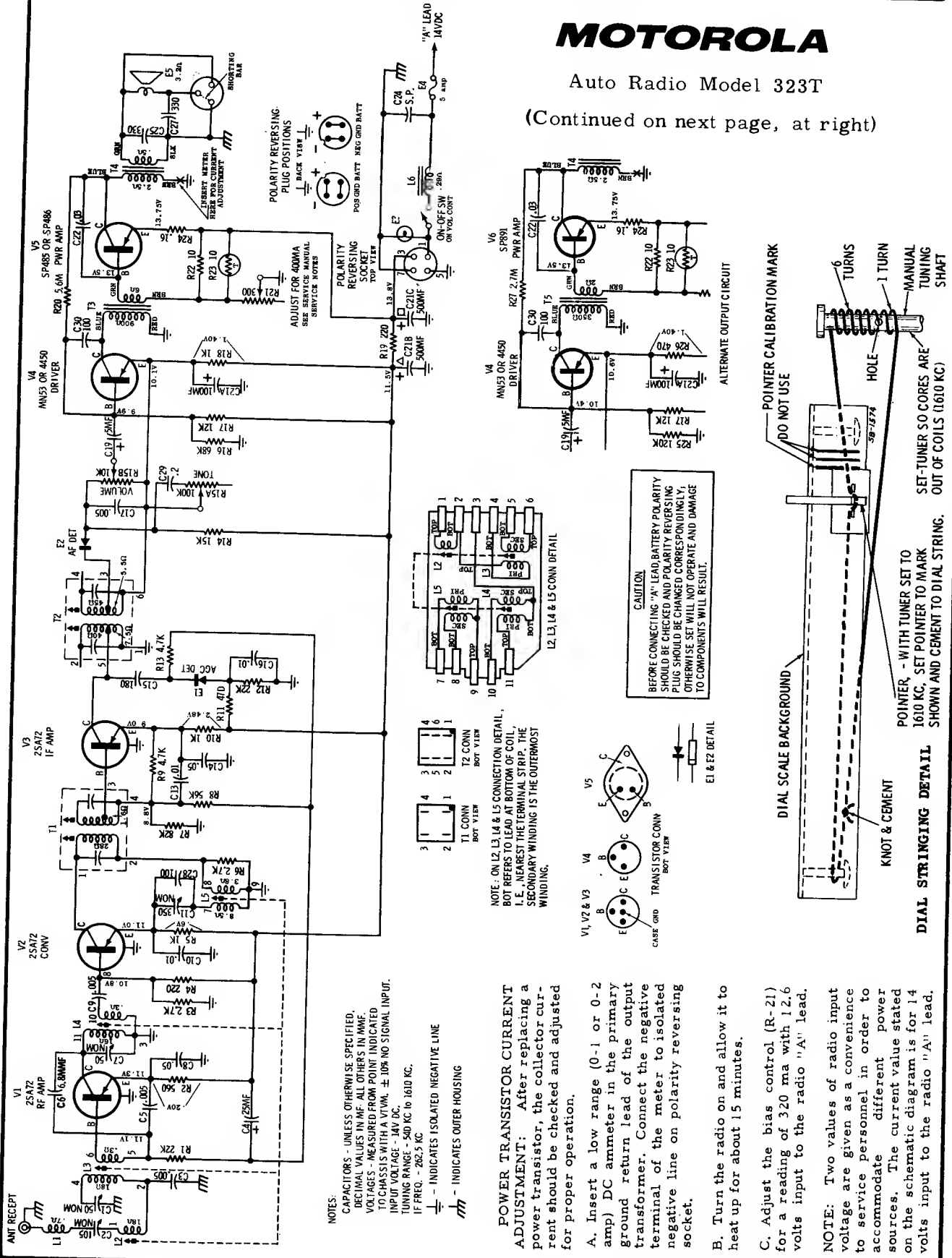

NOTES:
 CAPACITORS - UNLESS OTHERWISE SPECIFIED, DECIMAL VALUES IN MF. ALL OTHERS IN MMF.
 VOLTAGES - MEASURED FROM POINT INDICATED TO CHASSIS WITH A VTVM. ± 10% NO SIGNAL INPUT.
 INPUT VOLTAGE - 14V DC.
 TUNING RANGE - 540 KC TO 1610 KC.
 IF FREQ. - 262.5 KC
 ——— INDICATES ISOLATED NEGATIVE LINE
 ——— INDICATES OUTER HOUSING

POWER TRANSISTOR CURRENT ADJUSTMENT: After replacing a power transistor, the collector current should be checked and adjusted for proper operation.

A. Insert a low range (0-1 or 0-2 amp) DC ammeter in the primary ground return lead of the output transformer. Connect the negative terminal of the meter to isolated negative line on polarity reversing socket.

B. Turn the radio on and allow it to heat up for about 15 minutes.

C. Adjust the bias control (R-21) for a reading of 320 ma with 12.6 volts input to the radio "A" lead.

NOTE: Two values of radio input voltage are given as a convenience to service personnel in order to accommodate different power sources. The current value stated on the schematic diagram is for 14 volts input to the radio "A" lead.

MOTOROLA Auto Radio Model 323T (Continued from preceding page)

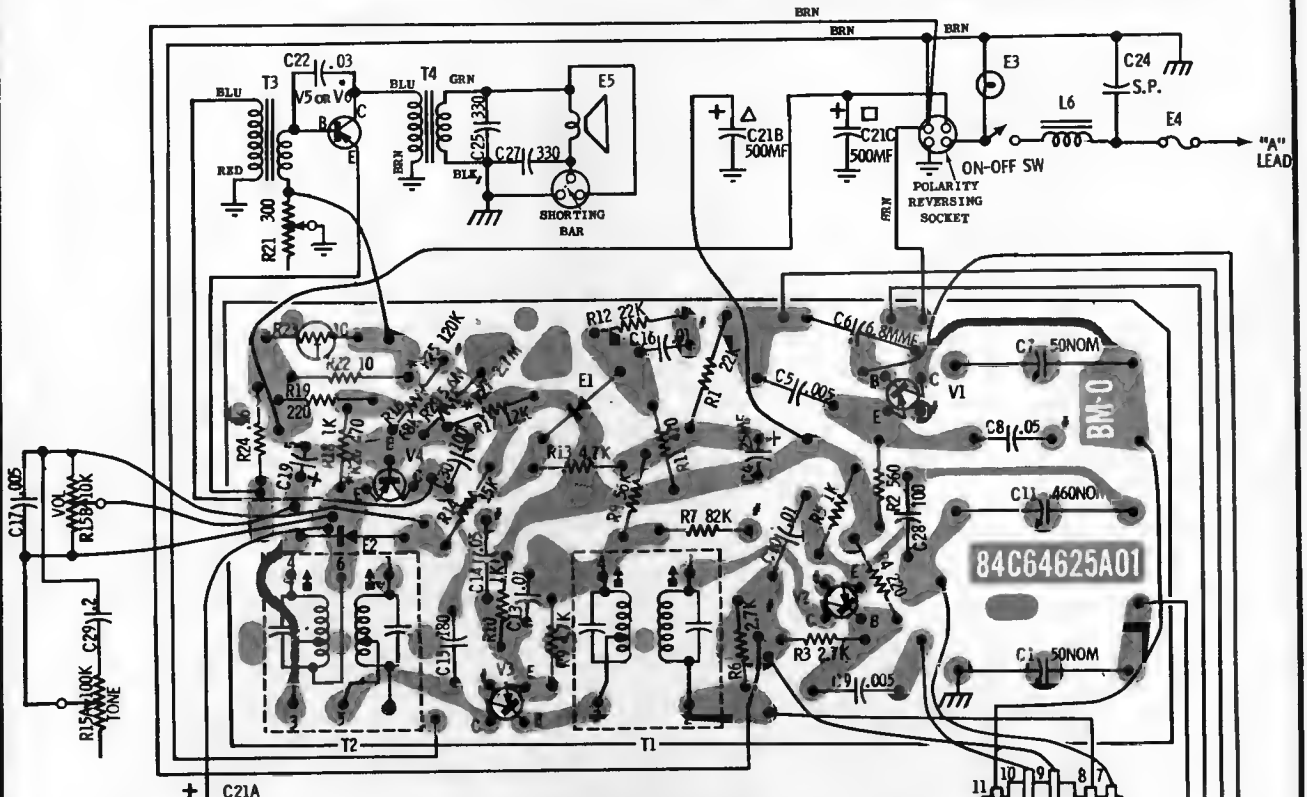

NOTES: * COMPONENTS VALUES USED IN ALTERNATE OUTPUT CIRCUIT ONLY.
 † POINT CONNECTS TO GND THRU COMPONENT SIDE PLATING.

auto radio
323T

PLATED CHASSIS BOARD WIRING DIAGRAM

COMPONENTS SHOWN ARE ACTUALLY LOCATED ON OPPOSITE SIDE - COMPONENT SIDE PLATING CONTAINS GROUND CONNECTIONS ONLY

Make certain the "A" lead is connected properly to power source i. e., check position of polarity reversing plug, otherwise, damage to receiver may result.

When replacing a power output transistor, remember to use the transistor specified in the parts list; coat both sides of the transistor insulator with DC-4 grease (Motorola Part No. 11M490487) and securely tighten the transistor mounting screws. When replacing all other transistors, use long-nose pliers as a heat sink, i. e., grasp transistor leads close to transistor base with the pliers to dissipate heat while soldering.

The plated chassis used in this receiver has plating on both sides; the exposed side (opposite components) contains the actual circuitry while the plating on the component side contains B- points only.

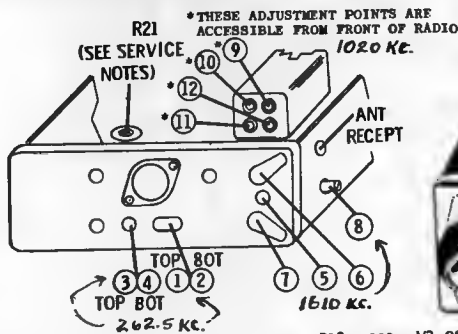

ALIGNMENT LOCATION DETAIL

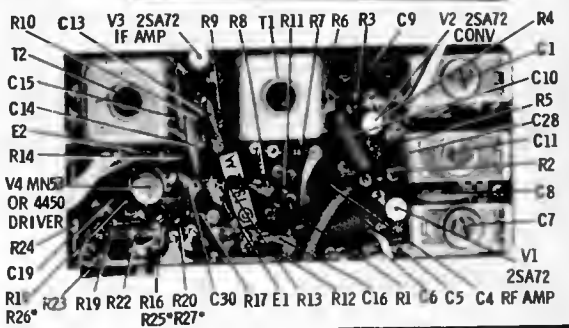

* SEE ALTERNATE OUTPUT CIRCUIT ON SCHEMATIC DIAGRAM

MOTOROLA

auto radio

413T

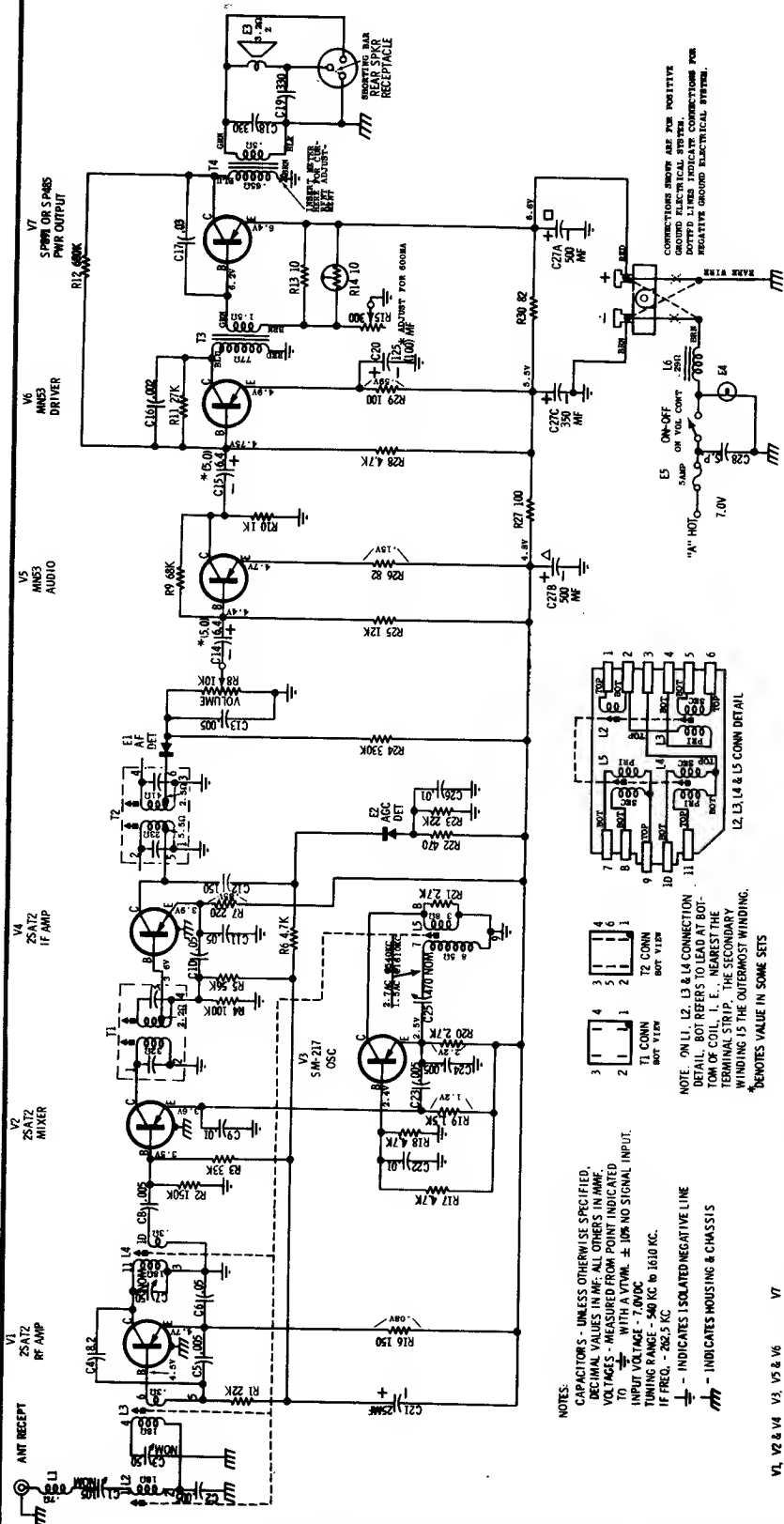

*THESE ADJUSTMENTS ARE ACCESSIBLE FROM FRONT OF RADIO @ 102.0 KC.

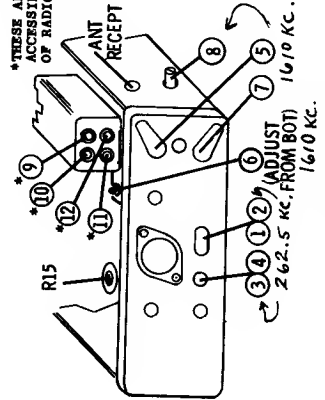

ALIGNMENT LOCATION DETAIL

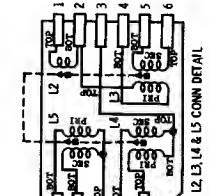

NOTE: ON L1, L2, L3 & L4 CONNECTION DETAIL, BOT REFERS TO LEAD AT BOTTOM OF COIL, I. E., NEAREST THE TERMINAL STRIP. THE SECONDARY WINDING IS THE OUTERMOST WINDING. * DENOTES VALUE IN SOME SETS

NOTES:
 CAPACITORS - UNLESS OTHERWISE SPECIFIED, DECIMAL VALUES IN MF; ALL OTHERS IN MMF.
 VOLTAGES - MEASURED FROM POINT INDICATED TO GND.
 * WITH A V.T.V.M. ± 10% NO SIGNAL INPUT.
 INPUT VOLTAGE - 7.0VDC
 TUNING RANGE - 540 KC TO 1610 KC.
 IF FREQ. - 286.5 KC
 - INDICATES ISOLATED NEGATIVE LINE
 - INDICATES HOUSING & CHASSIS

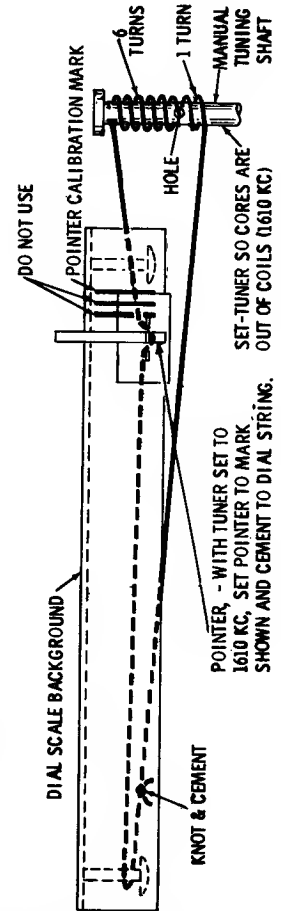
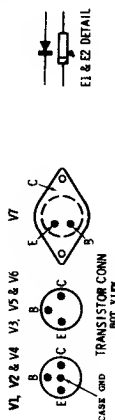

DIAL STRINGING DETAIL

MOTOROLA

MODEL CX2

CHASSIS HS-6110

V5
25B56
PWR AMP

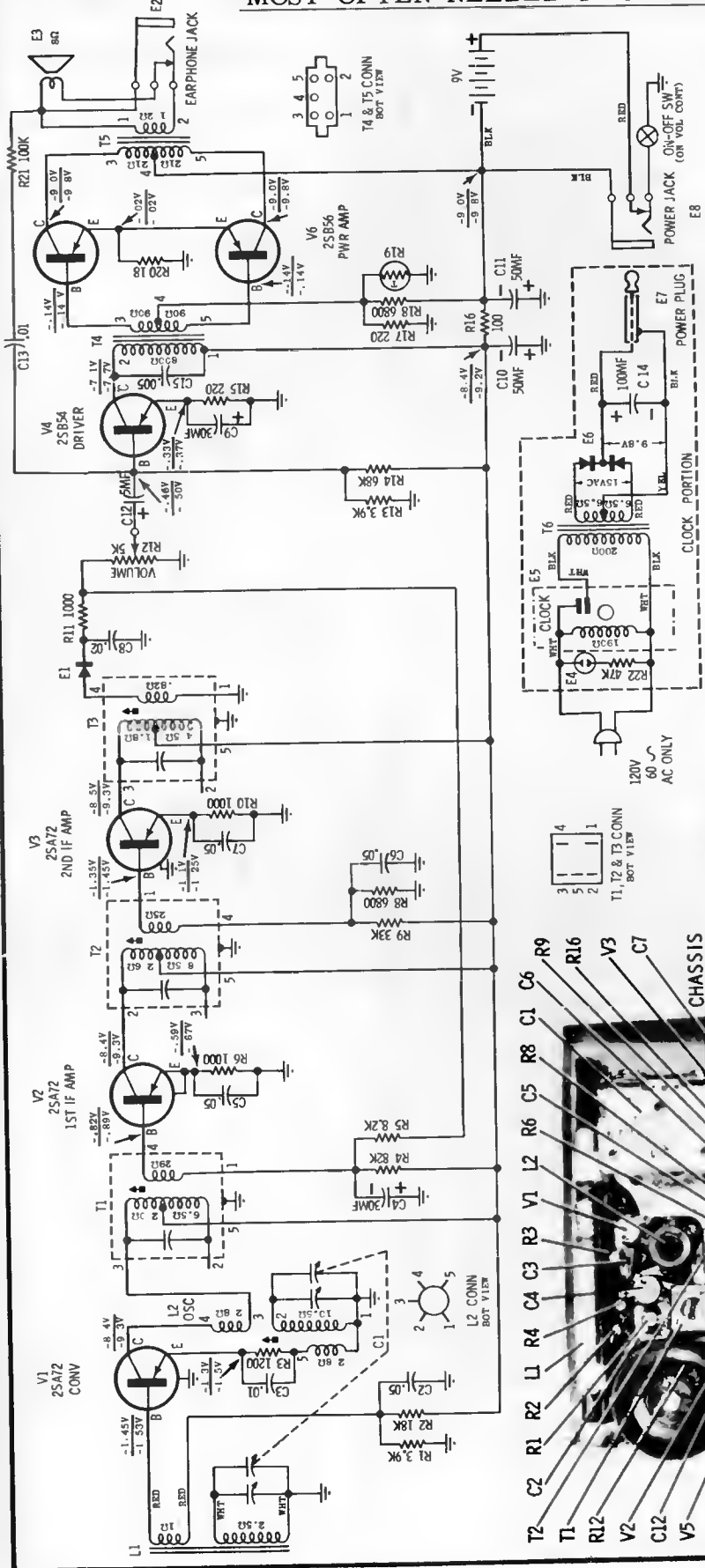

NOTES
 CAPACITORS - UNLESS OTHERWISE SPECIFIED, DECIMAL VALUES IN MF, ALL OTHERS IN MME. VOLTAGES - MEASURED FROM POINT INDICATED TO GROUND WITH A VTVM, $\pm 10\%$ NO SIGNAL IN, VOL AT MIN.
 TUNING RANGE - 535KC TO 1620KC
 ZERO SIGNAL CURRENT - APPROX 7.2MA (MIN VOL)
 V. VOLTAGES TAKEN WITH 9V AC POWER SOURCE
 V. VOLTAGES TAKEN WITH 120V AC POWER SOURCE

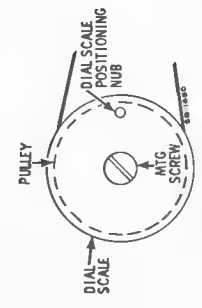
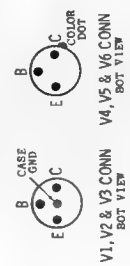

UPON COMPLETION OF DIAL STRINGING, INSTALL DIAL SCALE AS SHOWN.

DIAL STRINGING DETAIL

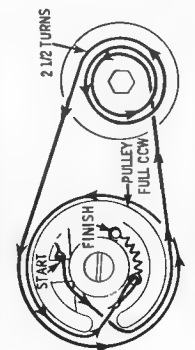

BEFORE STRINGING, ROTATE GANG SHAFT TO PULLEY FULLY COUNTER-CLOCKWISE; THEY SHOULD BE IN POSITION AS SHOWN.

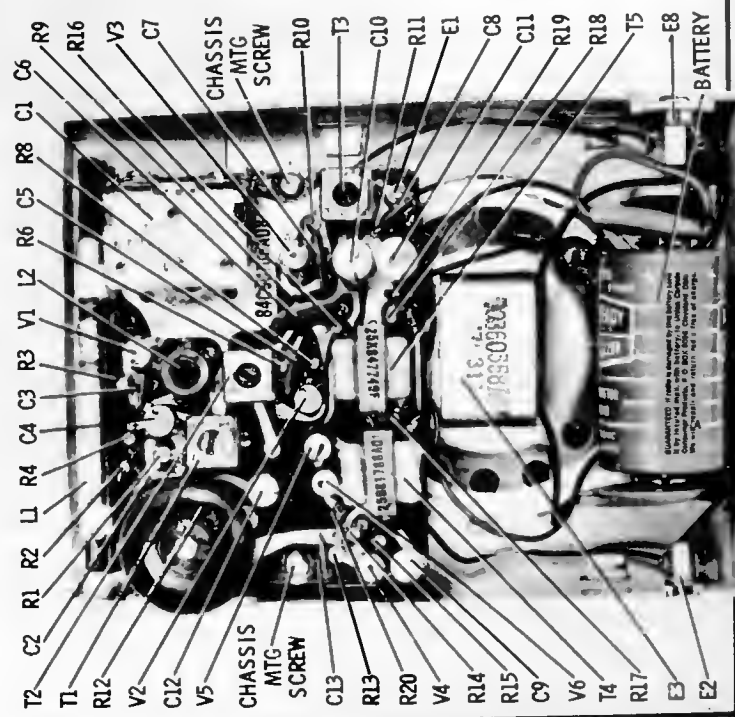

NOTE: C15, R5, R21 ARE LOCATED ON BOTTOM OF CHASSIS

MOTOROLA
MODELS BC2,BC3
CHASSIS HS-4124

(For additional data see next page, at right)

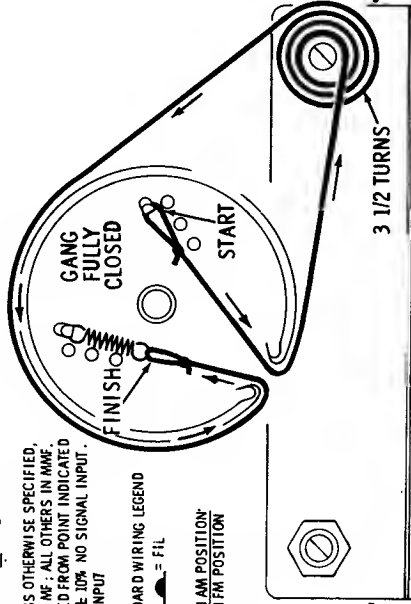
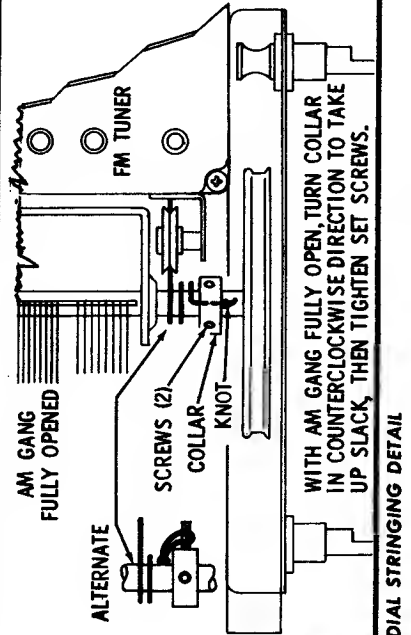
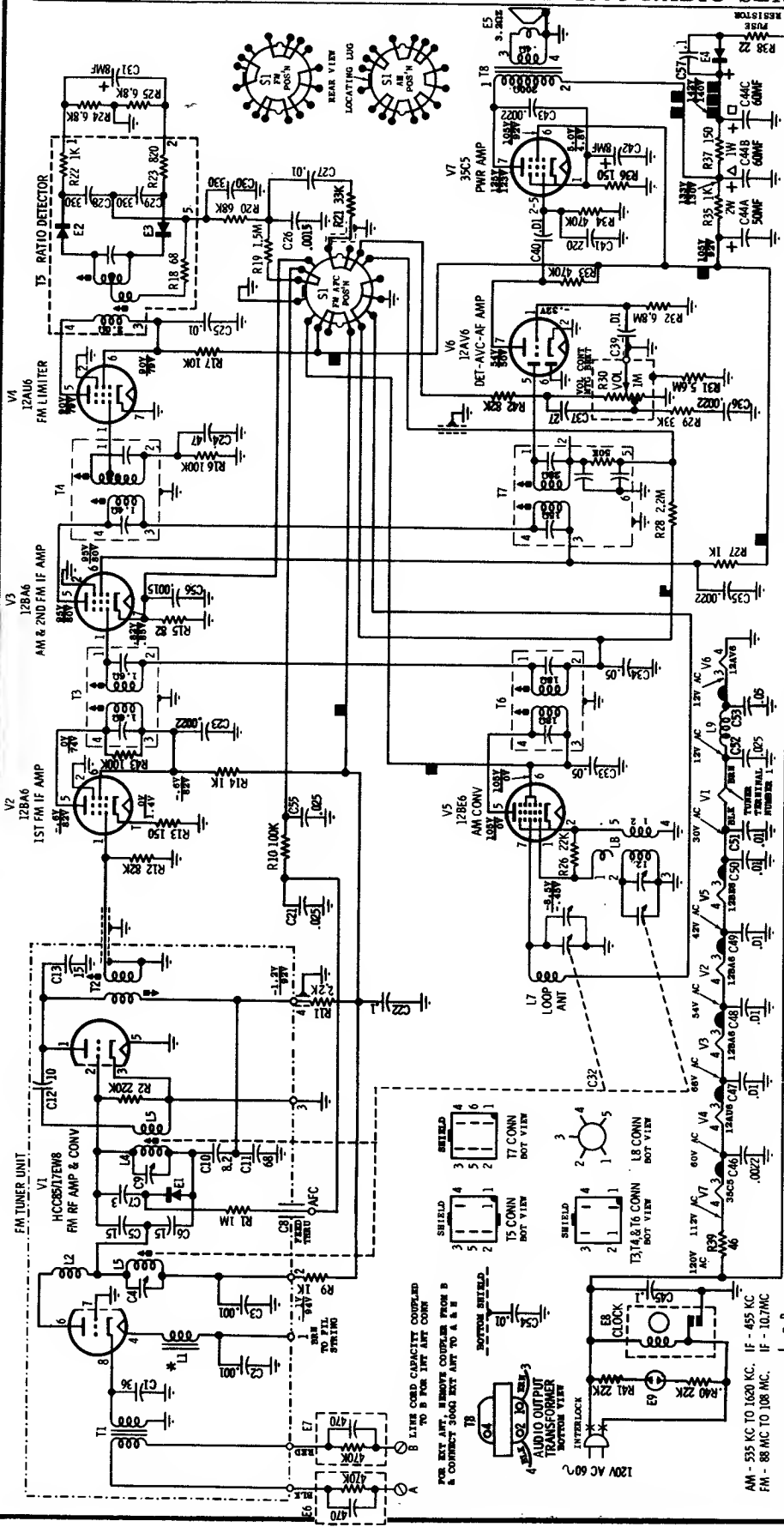

MOTOROLA

Models BC2, BC3,
Chassis HS-4124
(Continued)

TO REMOVE CHASSIS FROM CABINET

1. Remove control knobs - pull straight off.
2. Remove 4 clutch head screws holding cabinet back to cabinet.
3. Unsolder leads to cabinet back.
4. Remove two screws holding chassis support channel.
5. Remove two screws that mount the AM gang bracket to cabinet.
6. Remove dial crystal from cabinet - reach in back of set and push down plastic tabs with fingers. Crystal should slip forward at top. Bottom of crystal has tabs which fit into cabinet slots. Care should be taken to avoid damage to tabs.
7. Remove dial pointer - pull straight out.
8. Remove 2 chassis mounting nuts from front of radio.
9. Unsolder speaker leads.
10. Unsolder lead of bottom shield.
11. Slide AM loop out of slots inside cabinet.
12. Slide chassis out of cabinet. (Clock leads need not be disconnected to work on chassis.)

BOTTOM VIEW PLATED CHASSIS BOARD WIRING AS VIEWED FROM BOTTOM (COMPONENTS SHOWN ARE LOCATED ON OPPOSITE SIDE)

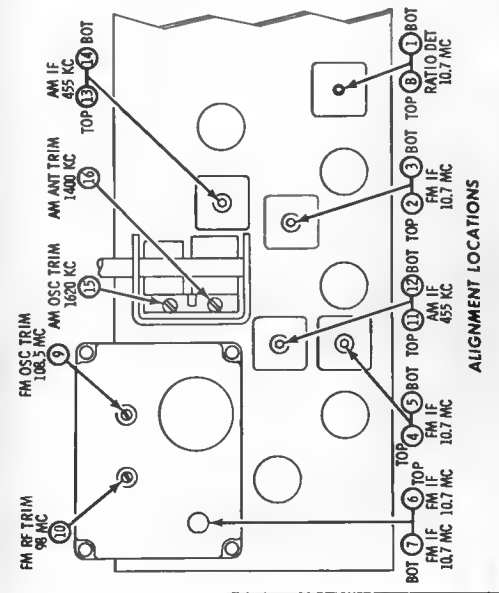
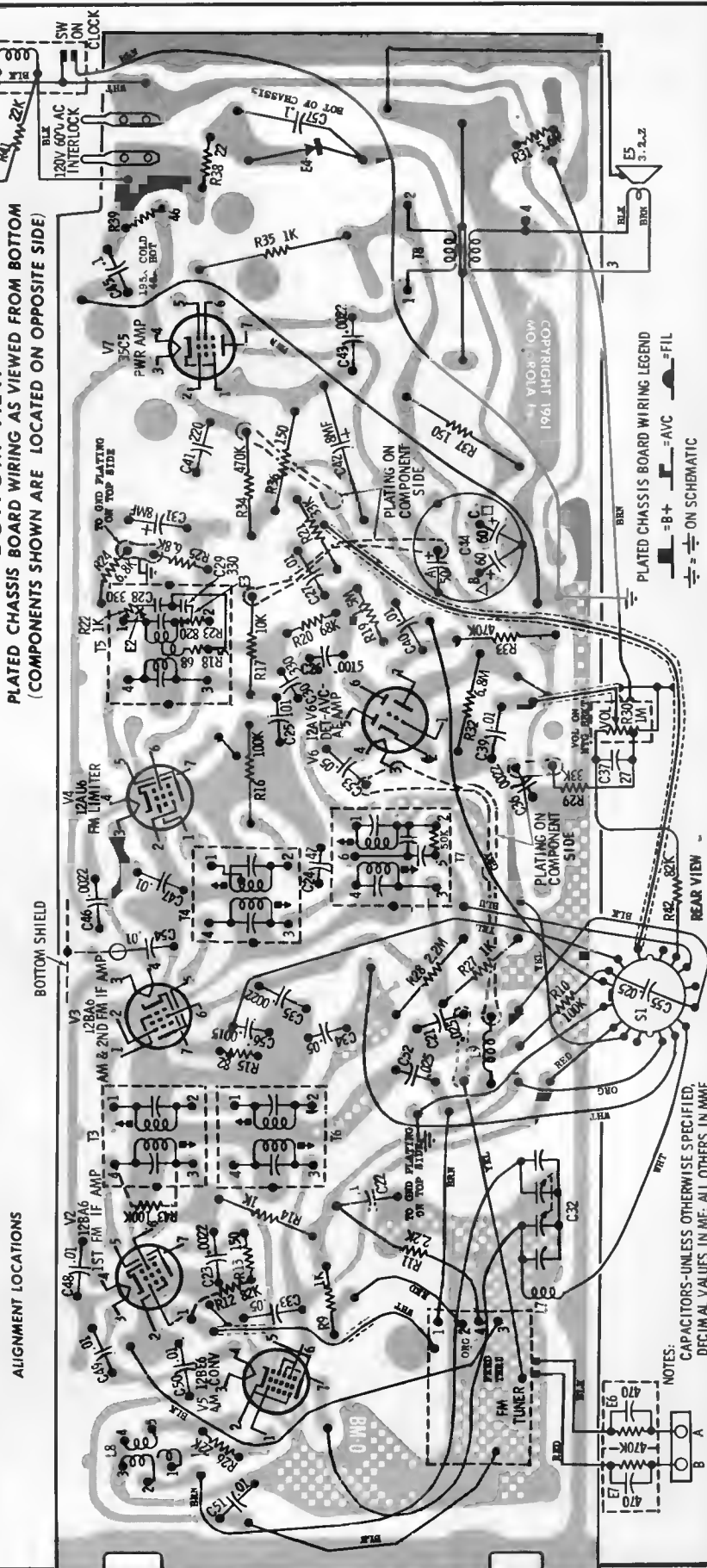

NOTES:
CAPACITORS-UNLESS OTHERWISE SPECIFIED,
DECIMAL VALUES IN MF; ALL OTHERS IN MMF.

MOTOROLA

MODEL A24

CHASSIS HS-4136

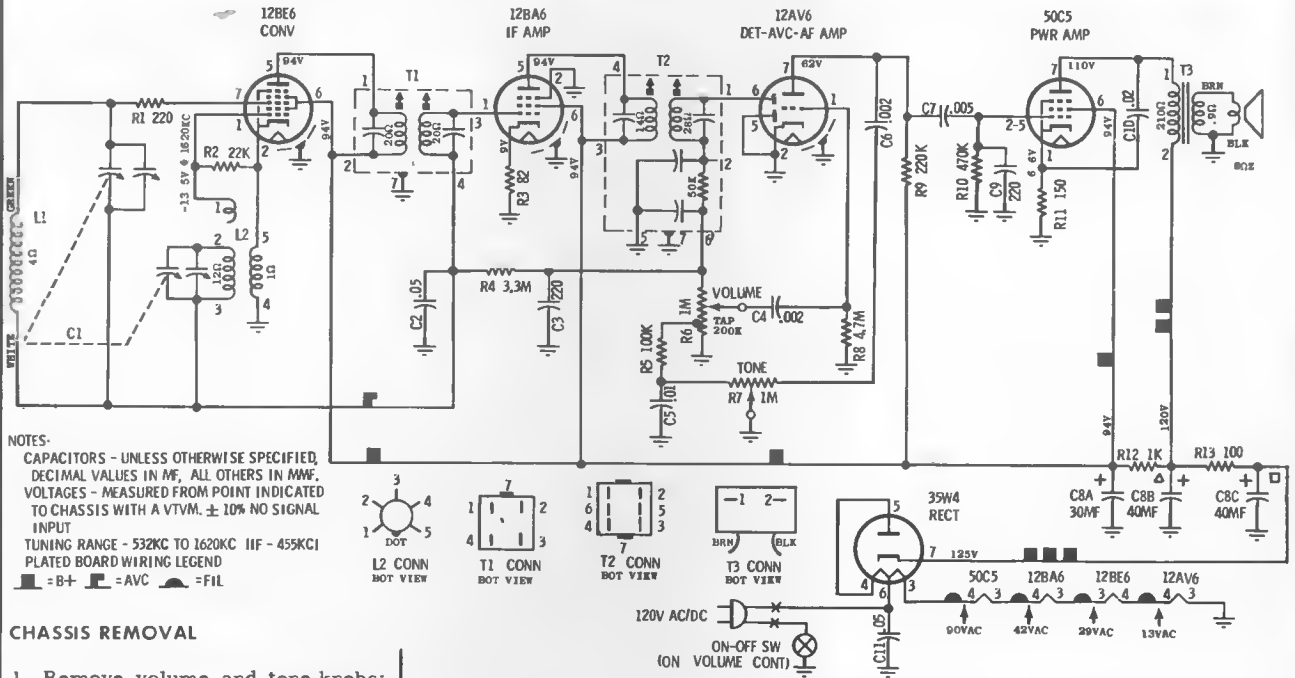

NOTES-
 CAPACITORS - UNLESS OTHERWISE SPECIFIED, DECIMAL VALUES IN MF, ALL OTHERS IN MMF. VOLTAGES - MEASURED FROM POINT INDICATED TO CHASSIS WITH A VTVM. ± 10% NO SIGNAL INPUT
 TUNING RANGE - 532KC TO 1620KC IIF - 455KC
 PLATED BOARD WIRING LEGEND
 ■ = B+ ▣ = AVC ▽ = FIL

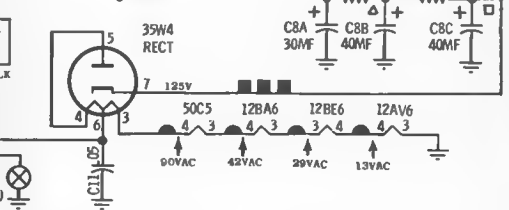
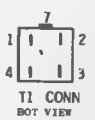
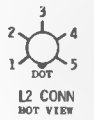

CHASSIS REMOVAL

1. Remove volume and tone knobs; do not attempt to remove captivated tuning knob.
2. Remove cabinet back - 4 screws hold it in place.
3. From rear, remove chassis mounting screw at base of chassis, if necessary, also remove two gang mounting screws.
4. Unsolder speaker leads (and gang leads, if gang was not removed in Step 3).
5. Slide chassis and antenna out of cabinet.

TUNING KNOB REMOVAL

1. Remove cabinet back - 4 screws hold it in place.
2. From rear, remove two gang mounting screws and pull back gang.
3. To remove tuning knob, remove speed clip from knob shank from rear of knob.

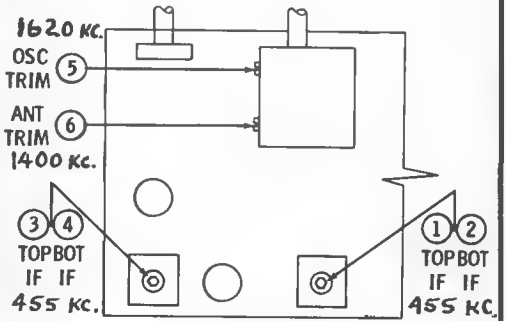

ALIGNMENT LOCATIONS

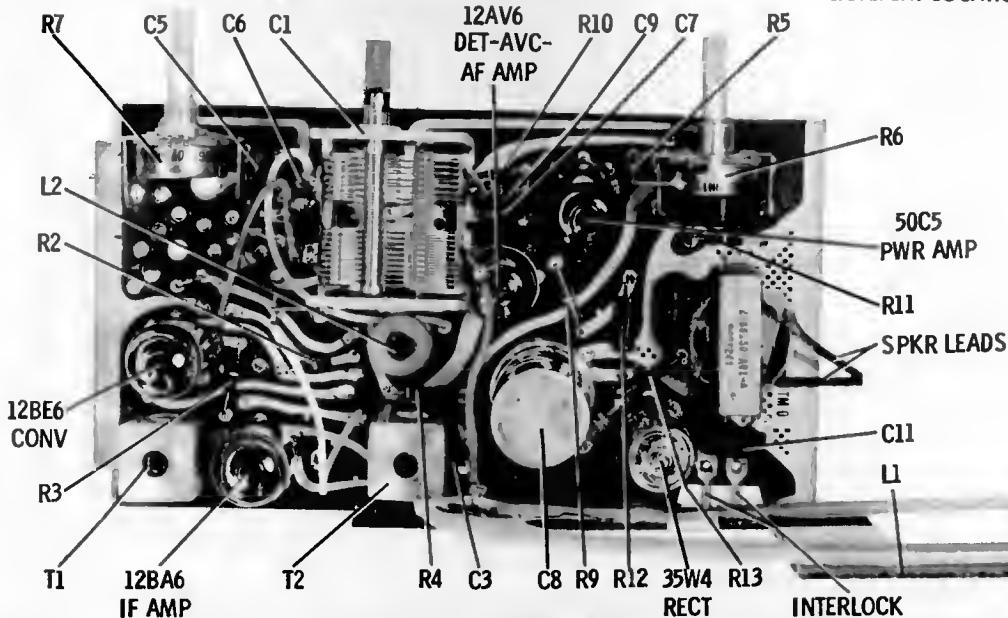

MOTOROLA MODELS C34,C35,C36 CHASSIS HS-998

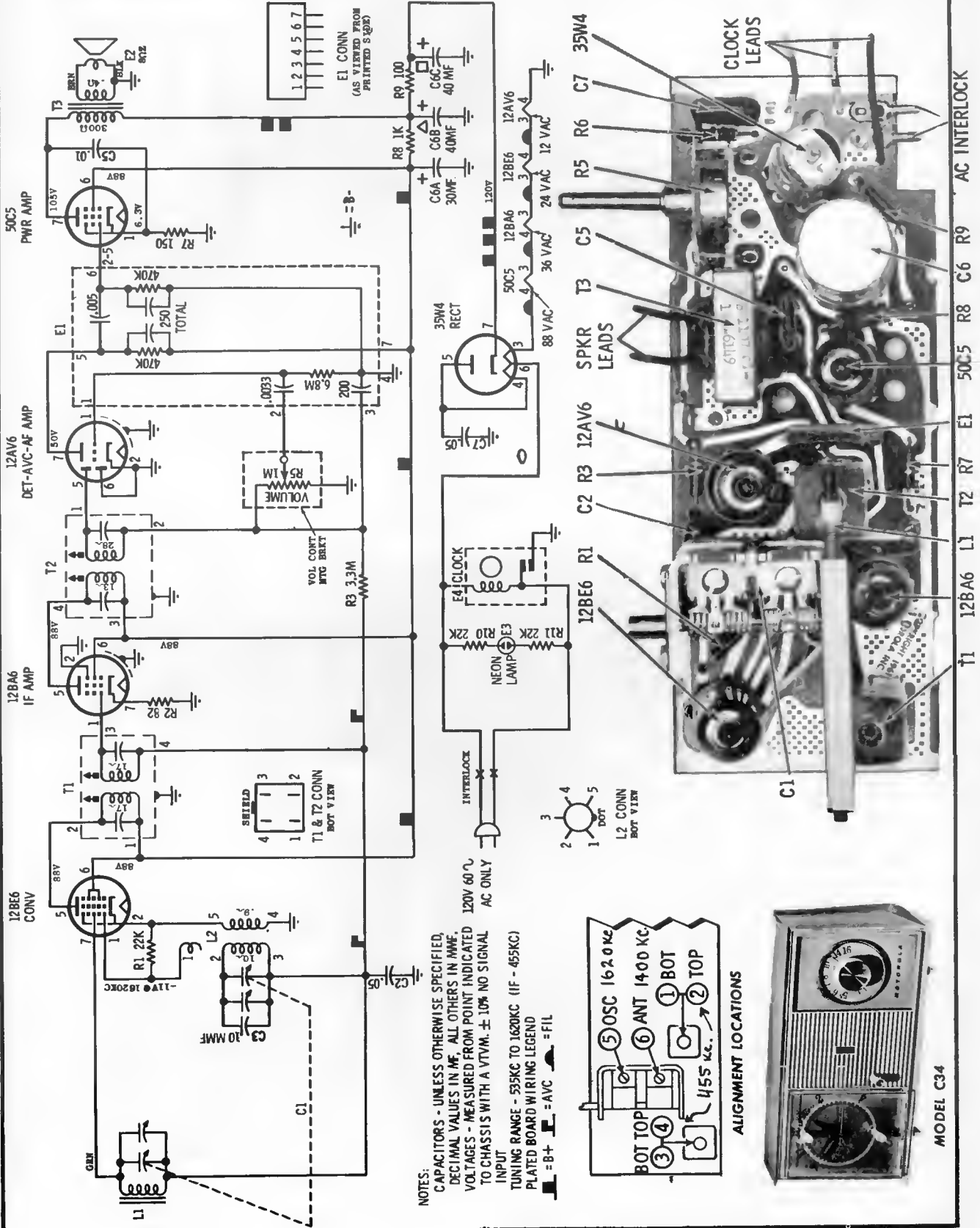

NOTES:
 CAPACITORS - UNLESS OTHERWISE SPECIFIED, DECIMAL VALUES IN MF, ALL OTHERS IN MMF. VOLTAGES - MEASURED FROM POINT INDICATED TO CHASSIS WITH A VTVM, ± 10% NO SIGNAL INPUT
 TUNING RANGE - 535KC TO 1620KC (IF - 455KC)
 PLATED BOARD WIRING LEGEND
 ■ = B+ ⊣ = AVC ○ = FIL

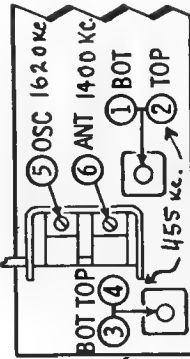

ALIGNMENT LOCATIONS

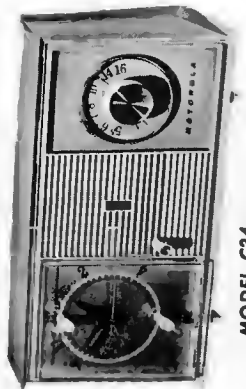

MODEL C34

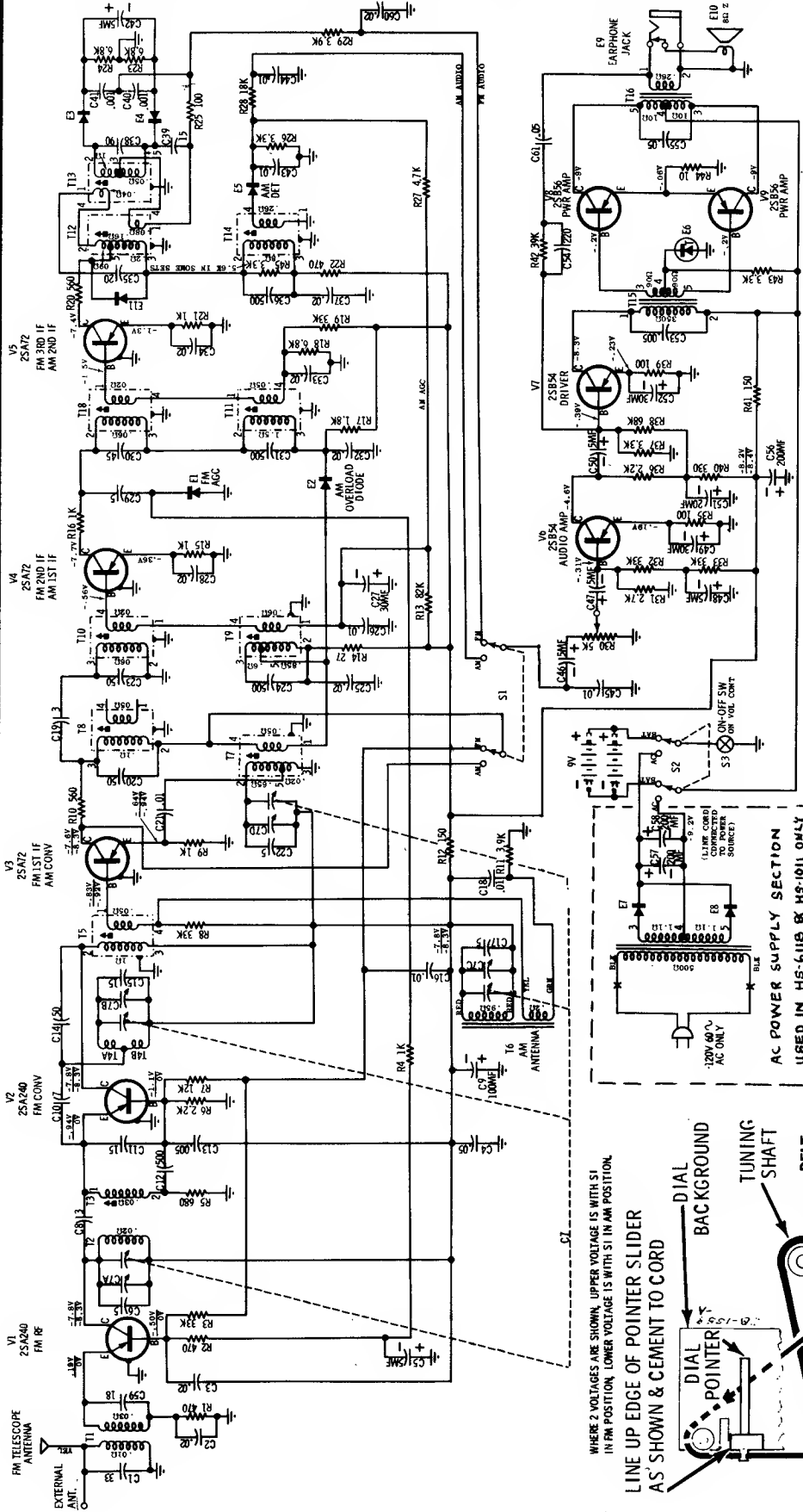

MOTOROLA

MODEL X70 CHASSIS HS-6117
MODEL X42-1 CHASSIS HS-6118

This material is also applicable to
MODEL X42 CHASSIS HS-1011
 which is almost identical to X42-1

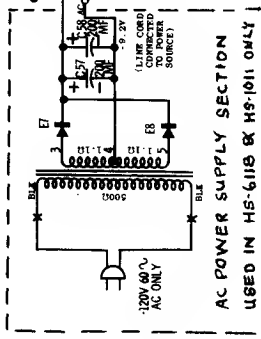
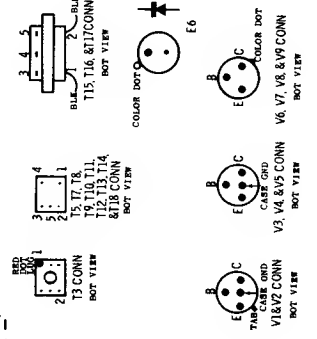

NOTES:
 CAPACITORS UNLESS OTHERWISE SPECIFIED
 ARE MFD. RESISTORS UNLESS OTHERWISE
 SPECIFIED ARE OHMS. VOLTAGES MEASURED FROM
 POINT INDICATED TO GROUND WITH A VTVM.
 ±10% NO SIGNAL IN VOL AT MIN. AM RANGE 88MC TO 108MC
 FM RANGE 88MC TO 108MC
 AM IF 455KC
 ZERO SIGNAL CURRENT APPROX 16MA (MIN VOL)
 VOLTAGES TAKEN WITH 9V BATTERY

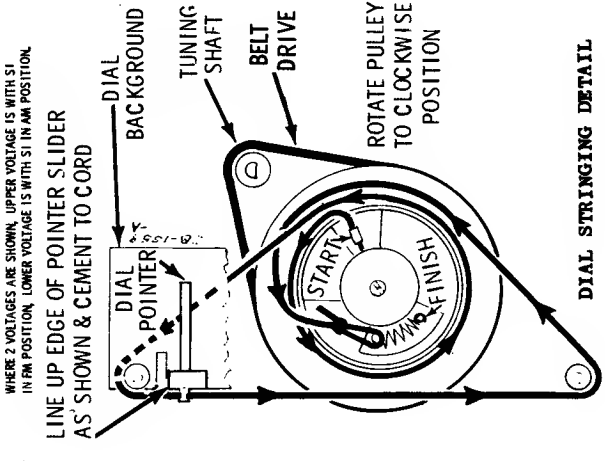

MOTOROLA MODEL X47

CHASSIS HS-6108

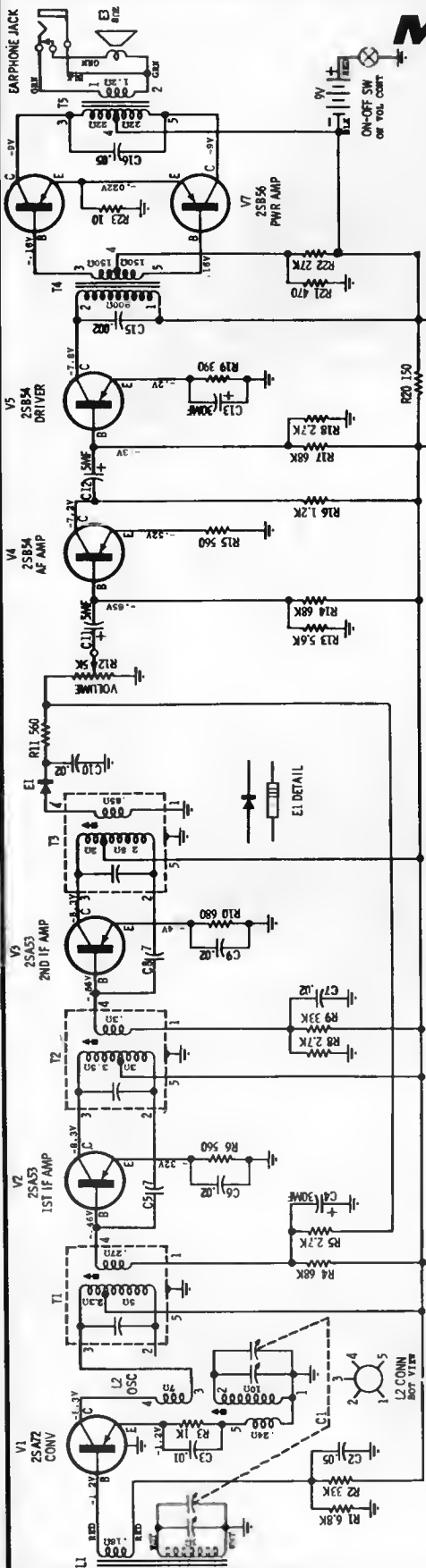

NOTES:

- CAPACITORS - UNLESS OTHERWISE SPECIFIED, DECIMAL VALUES IN MF; ALL OTHERS IN MMF.
- VOLTAGES - MEASURED FROM POINT INDICATED TO GROUND WITH A VTVM ± 10% NO SIGNAL IN, SCALE VOL. AT MIN.
- ZERO SIGNAL CURRENT - APPROX. 7.5 MA (MIN VOL)
- TUNING RANGE - 532 TO 1620 KC
- IF - 455 KC

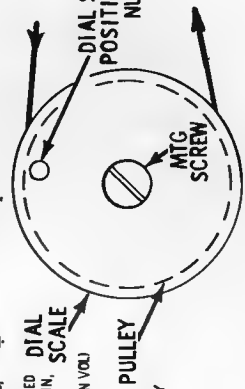

BEFORE INSTALLING DIAL SCALE, REMOVE MTG SCREW BUT HOLD ONTO PULLEY.

BEFORE STARTING STRINGING, ROTATE GANG SHAFT & PULLEY FULLY COUNTERCLOCKWISE; THEY SHOULD BE IN POSITION AS SHOWN.



R21 NOTE: C5, C8, C15, C16 & R5 ARE LOCATED ON BOTTOM OF CHASSIS T5 R22 C17

MOTOROLA

MODEL X48

CHASSIS HS-6111

MOTOROLA
MODEL X48
CHASSIS HS-6111

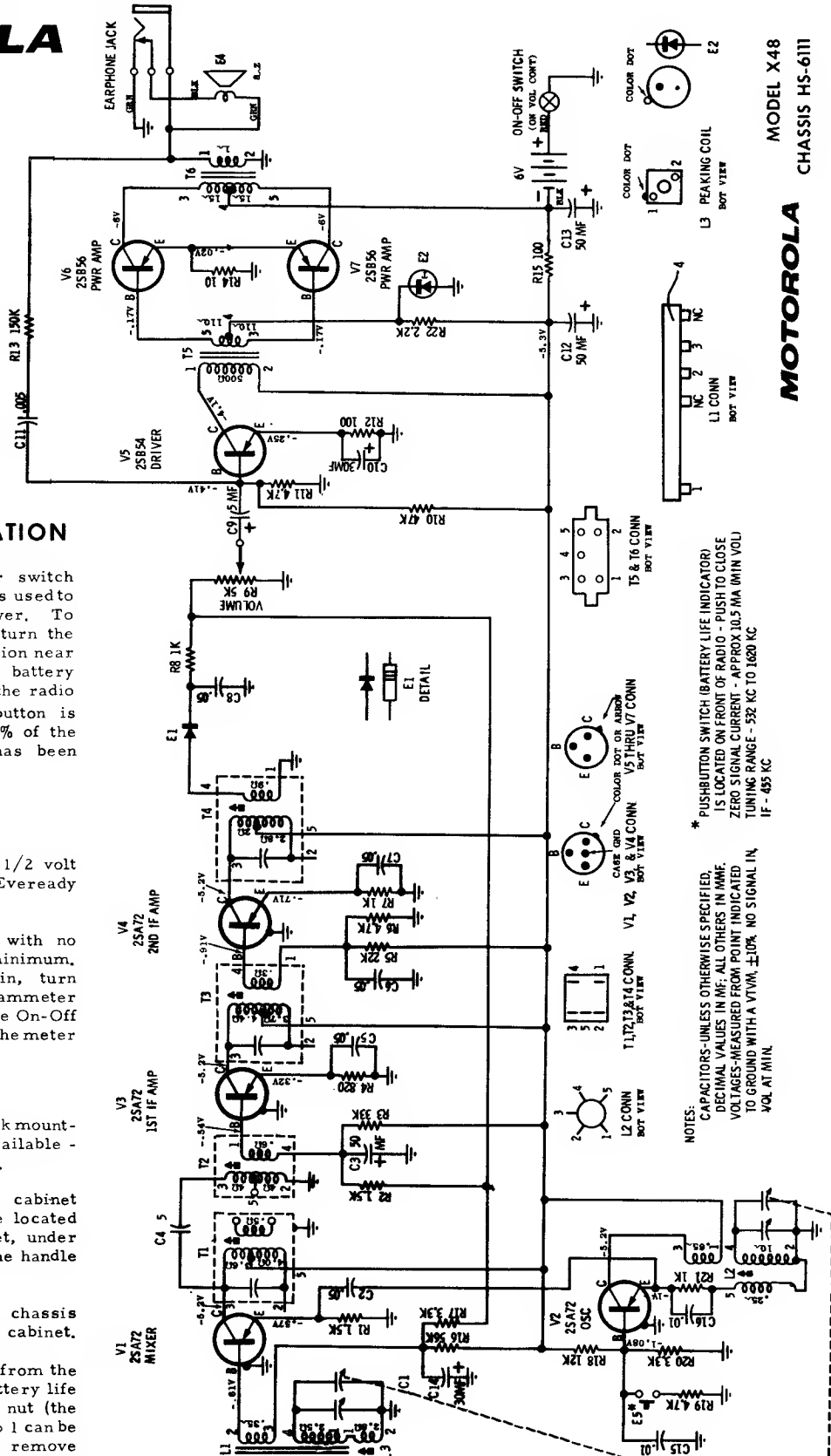

GENERAL INFORMATION

The battery life indicator switch (located on front of radio) is used to check for low battery power. To check the batteries, first turn the radio on and tune to a station near 1000Kc, then, press the battery indicator switch button; if the radio stops playing while the button is held in, approximately 90% of the available battery power has been used up.

Power Supply

Operates from four (4) 1-1/2 volt batteries; use four (4) Eveready #1015 or equivalent.

Battery Drain - 10.5 ma with no input signal and volume at minimum. To measure battery drain, turn radio off and connect a milliammeter across the terminals of the On-Off switch (observe polarity); the meter should read 10.5 ma.

Chassis Removal

1. Remove the earphone jack mounting nut (a special tool is available - order Part No. 66A646211).
2. Remove the two (2) cabinet mounting screws (they are located on the sides of the cabinet, under the carrying handle - lift the handle to expose them).
3. Lift the escutcheon and chassis as an assembly out of the cabinet.
4. To remove the chassis from the escutcheon, remove the battery life indicator switch mounting nut (the same tool described in Step 1 can be used to remove this nut), remove three (3) chassis mounting screws and, if necessary, unsolder leads connected to chassis.

* PUSHBUTTON SWITCH (BATTERY LIFE INDICATOR) IS LOCATED ON FRONT OF RADIO - PUSH TO CLOSE ZERO SIGNAL CURRENT - APPROX 10.5 MA (MIN VOL) TUNING RANGE - 532 KC TO 1620 KC IF - 455 KC

NOTES:
CAPACITORS - UNLESS OTHERWISE SPECIFIED, DECIMAL VALUES IN MF; ALL OTHERS IN MMF.
VOLTAGES - MEASURED FROM POINT INDICATED TO GROUND WITH A VTVM, ±10%, NO SIGNAL IN VOL AT MIN.

MOTOROLA

MODEL X49, X50

CHASSIS HS-6112

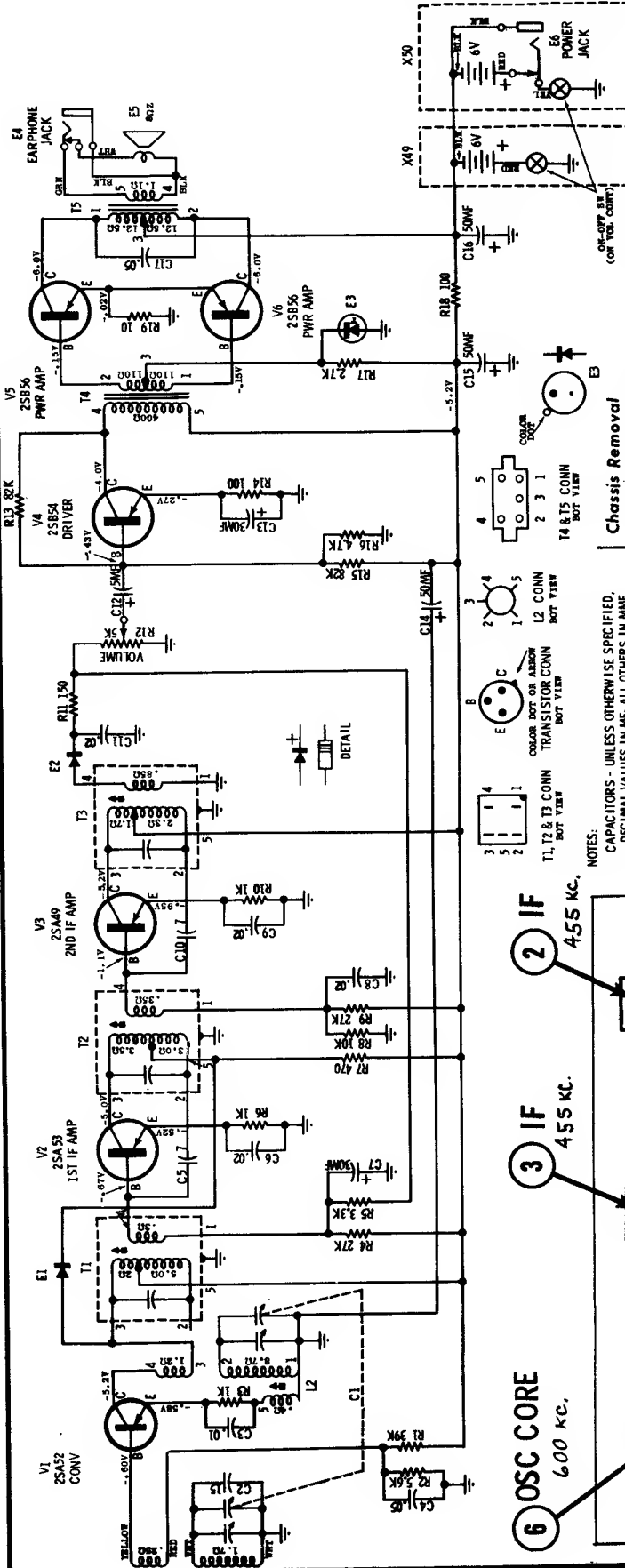

Chassis Removal

1. From front of radio, remove two (2) control knobs and the screw located under the tuning knob.
2. From rear of radio, open back panel by unsnapping the three (3) tabs at bottom of panel; then, lift battery retainer and AC power supply (X50 only) out of their compartment at rear of cabinet.
3. Lift armitie insulator to gain access to chassis.
4. Remove three (3) chassis mounting screws and unsnap antenna from its mounting clamps. If necessary, unsolder leads connected to chassis before removing chassis from the cabinet.
5. If it becomes necessary to remove the earphone jack or the power jack (X50), a special inexpensive tool is available

Power Supply

These radios operate from four (4) 1-1/2 volt batteries; use four (4) Eveready #1015 or equivalent. Model X50, in addition, can be powered from a 120 volt, 60 cycle AC power outlet by using the AC power supply included with the radio.

Battery Drain - 9.5 ma with no input signal and volume at minimum. To measure battery drain, turn radio off and connect a milliammeter across the terminals of the On-Off switch (observe polarity); the meter should read 9.5 ma.

NOTES:

- CAPACITORS - UNLESS OTHERWISE SPECIFIED, DECIMAL VALUES IN MF; ALL OTHERS IN MMF.
- VOLTAGES - MEASURED FROM POINT INDICATED TO GROUND WITH A VTVM, $\pm 10\%$ NO SIGNAL IN, VOL AT MIN.
- TUNING RANGE - 532 KC TO 1620 KC
- IF - 455 KC
- ZERO SIGNAL CURRENT - APPROX 65 MA (MIN VOL)

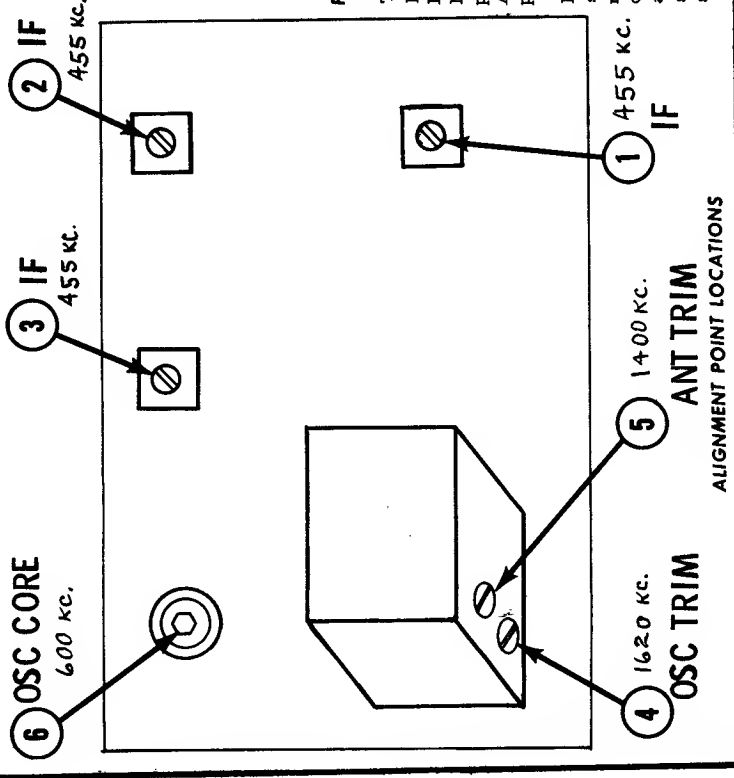

MOTOROLA

MODEL X51 CHASSIS HS-6114

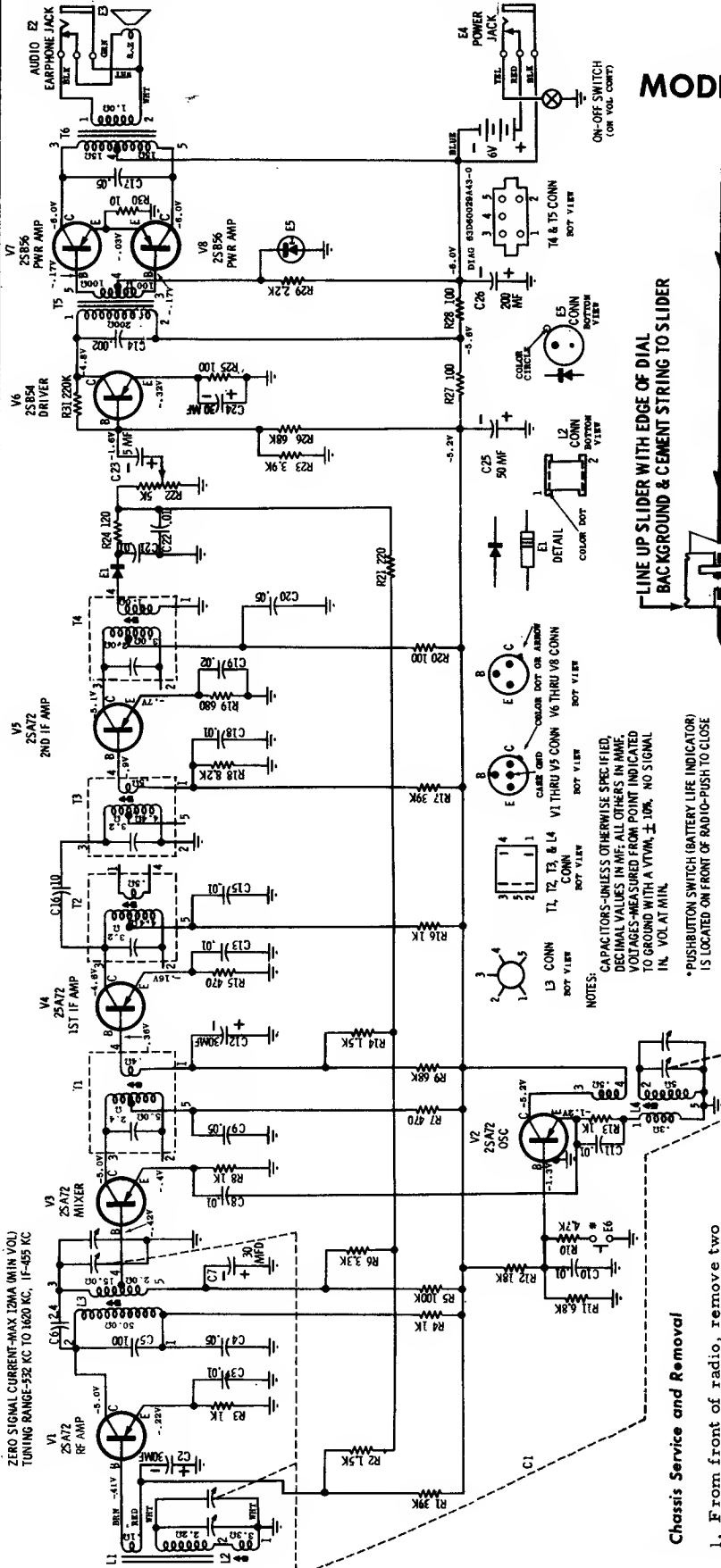

ZERO SIGNAL CURRENT—MAX 120mA (MIN VOL)
TUNING RANGE—532 KC TO 1620 KC, IF—455 KC

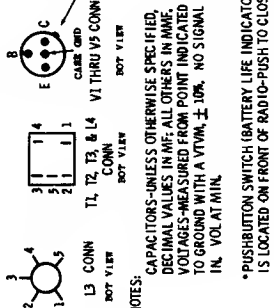

NOTES:
CAPACITORS—UNLESS OTHERWISE SPECIFIED,
DECIMAL VALUES IN MFD; ALL OTHERS IN PPMF.
VOLTAGES—MEASURED FROM POINT INDICATED
TO GROUND WITH A VTVM, $\pm 10\%$, NO SIGNAL
IN VOL AT MIN.

*PUSHBUTTON SWITCH BATTERY LIFE INDICATOR
IS LOCATED ON FRONT OF RADIO—PUSH TO CLOSE

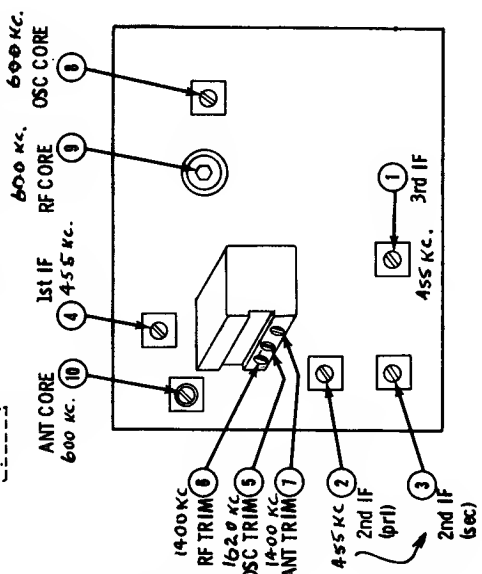
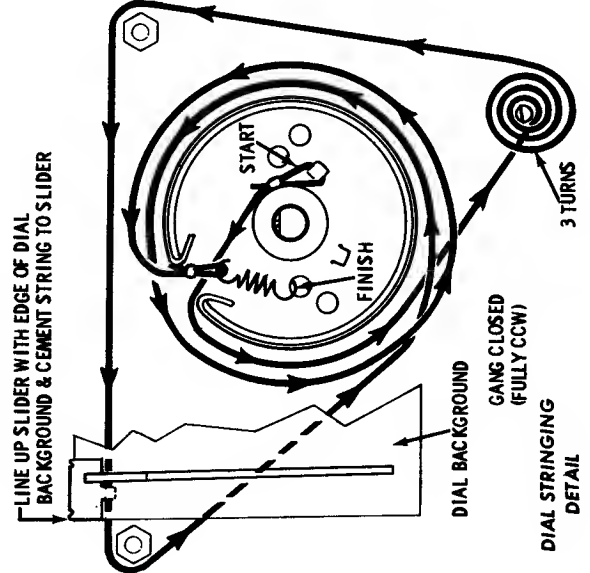

Chassis Service and Removal

1. From front of radio, remove two (2) control knobs and nuts that mount the earphone jack and the external power supply jack (a special tool is available - order Part No. 66A646211).
2. Remove three (3) cabinet back mounting screws (two (2) are located under the carrying handle; the other is located on the bottom of the cabinet).
3. Lift out escutcheon and chassis from cabinet back.
4. Remove two (2) antenna mounting screws.
5. Remove five (5) chassis mounting screws and lift up chassis and antenna; if necessary, unsolder the chassis connecting leads and remove the nut that mounts the battery life indicator switch.

MOTOROLA

**MODEL X54
CHASSIS HS-6123**

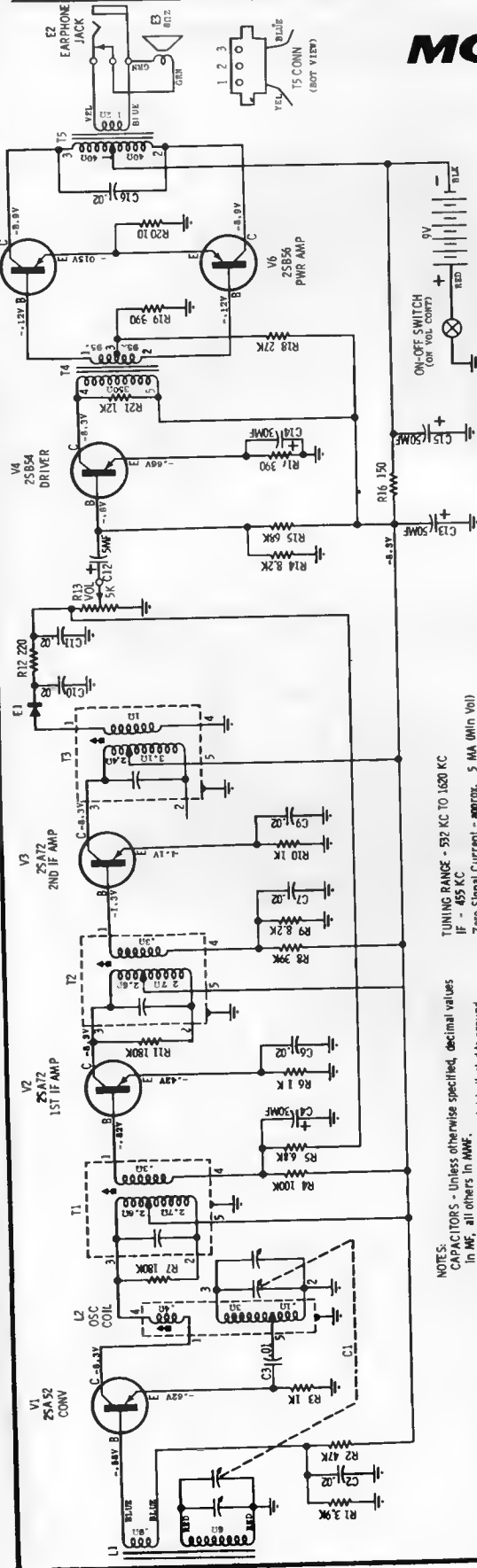
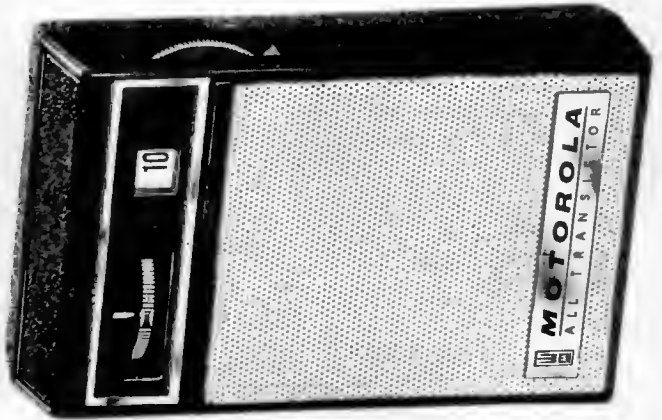

NOTES:
CAPACITORS - Unless otherwise specified, decimal values in MF, all others in MMF.
VOLTAGES - Measured from point indicated to ground with a VTVM, $\pm 10\%$. No signal in, vol μ in.

TUNING RANGE - 532 KC TO 1620 KC
IF - 455 KC
Zero Signal Current - approx. 5 MA (Min Vol)

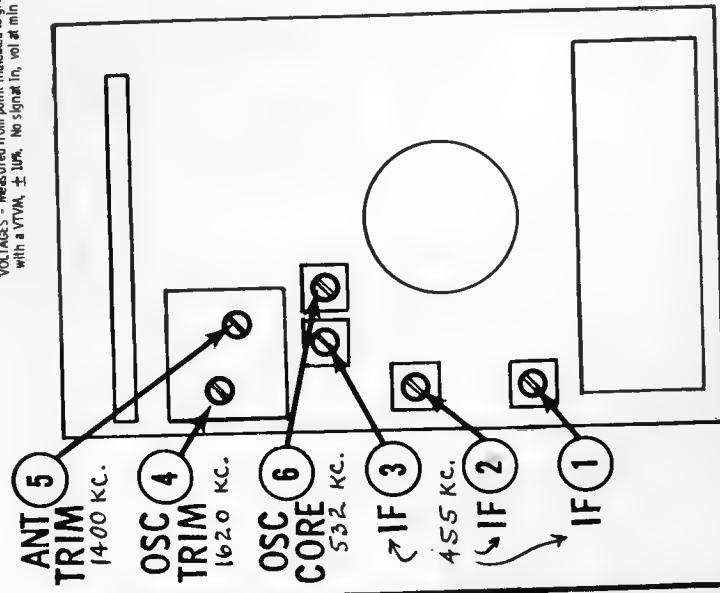

Power Supply

Operates from one (1) 9-volt battery; use Eveready #206 or equivalent.

Battery Drain - 5.0 ma with no input signal and volume at minimum. To measure battery drain, turn radio off and connect a milliammeter across the on-off switch (observe polarity); the meter should read 5.0 ma.

Chassis Removal

1. Remove cabinet back by applying thumb pressure at bottom; then remove one (1) chassis mounting screw located next to tuning gang.
2. Spread cabinet slightly at right side (adjacent to volume control) until chassis is free from its two (2) chassis retainers (part of cabinet). Lift chassis up until it clears all three (3) retainers.
3. If necessary, unsolder all chassis connecting leads. If it becomes necessary to remove the earphone jack, pull jack retainer out of the groove in cabinet wall.

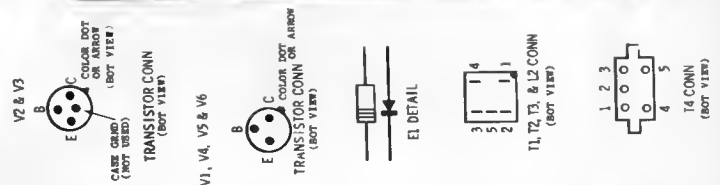

MOTOROLA MODEL X56 CHASSIS HS-6124

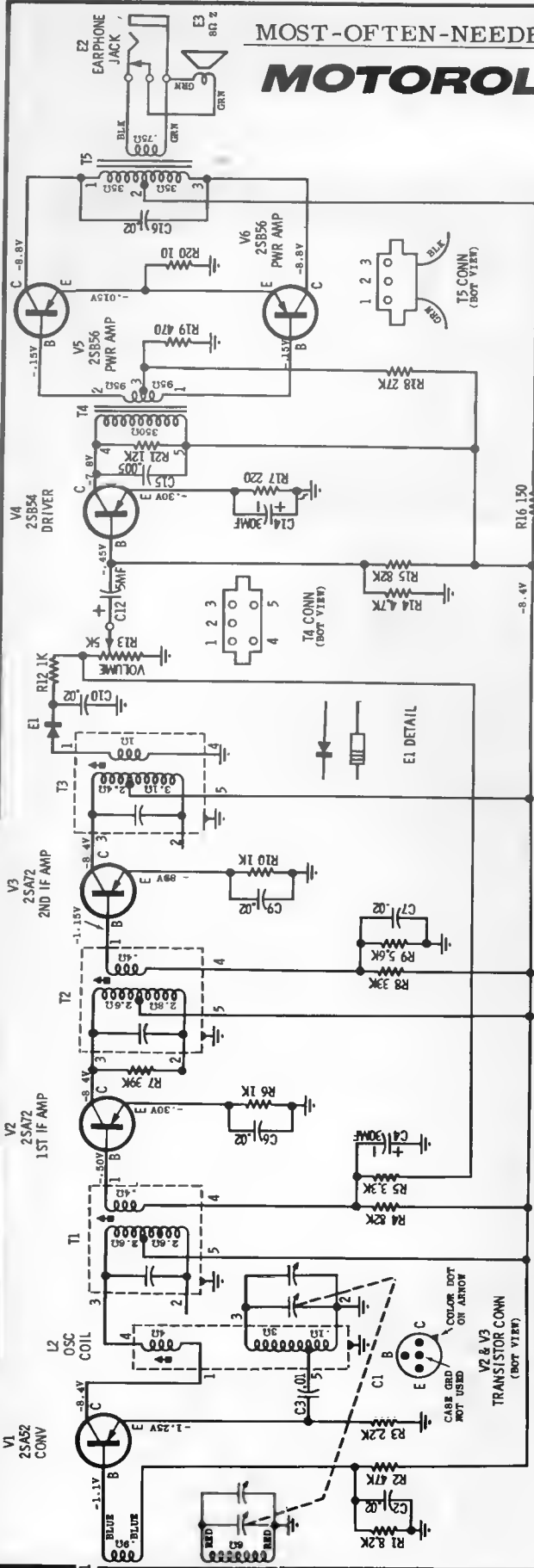

NOTES:
 CAPACITORS - UNLESS OTHERWISE SPECIFIED, DECIMAL VALUES IN MF. ALL OTHERS IN MMF.
 VOLTAGES - MEASURED FROM POINT INDICATED TO GROUND WITH A VTVM, $\pm 10\%$, NO SIGNAL IN VOL AT MIN. ZERO SIGNAL CURRENT - APPROX. 5.5 MA UNIN VOLU

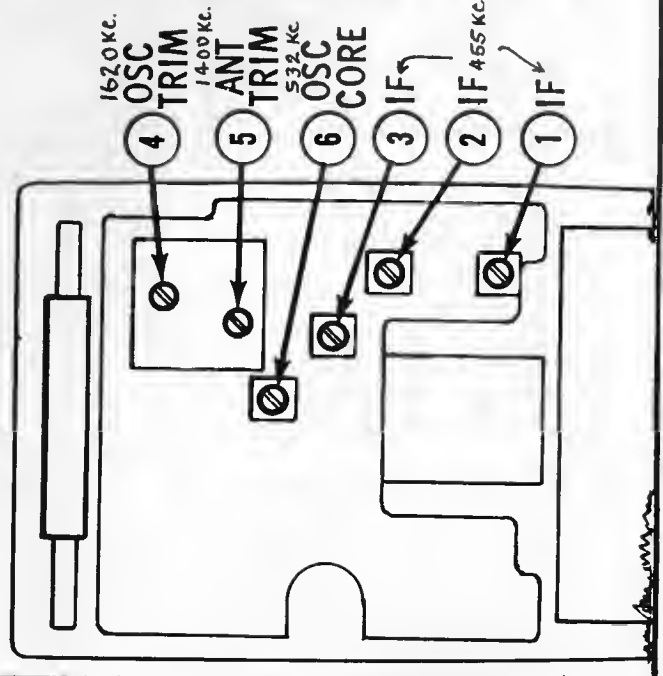
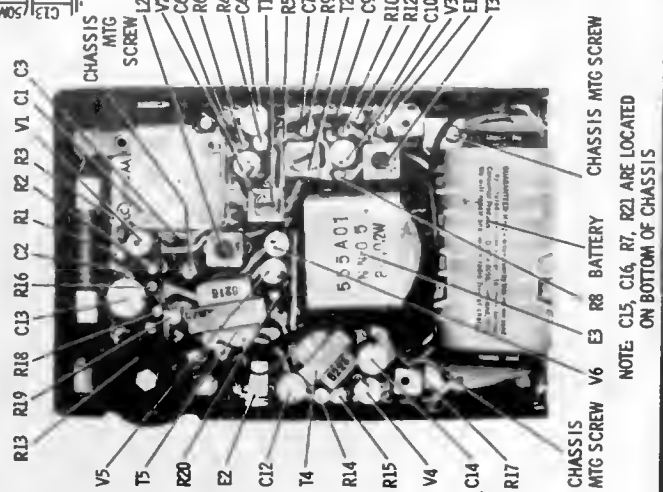
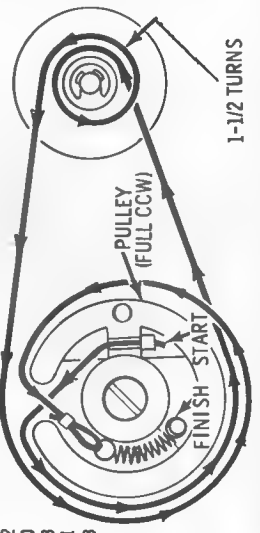

PARTS LOCATION

ALIGNMENT LOCATIONS

MOTOROLA MODEL SP51 CHASSIS HS-1134

CHASSIS REMOVAL

1. Remove 4 screws that mount the record changer mounting board to the cabinet.
2. Lift up the record changer mounting board to gain access to underside of record changer, then unsolder and disconnect all leads that are connected from chassis to record changer and speaker.
3. Remove 3 control knobs and two large chassis mounting nuts and washers, then remove chassis from cabinet; if necessary, remove 4 screws that mount control bracket to chassis to expose chassis interior and controls.

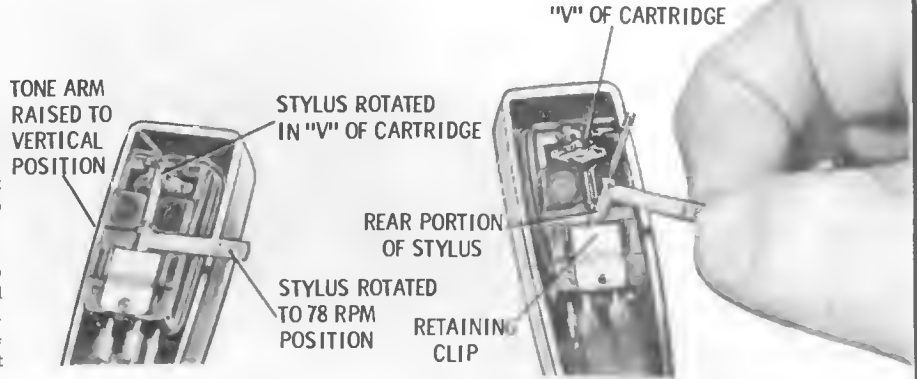

LINE CORD REVERSAL - For minimum hum, insert line cord plug in both positions. Leave it in the position that provides minimum hum.

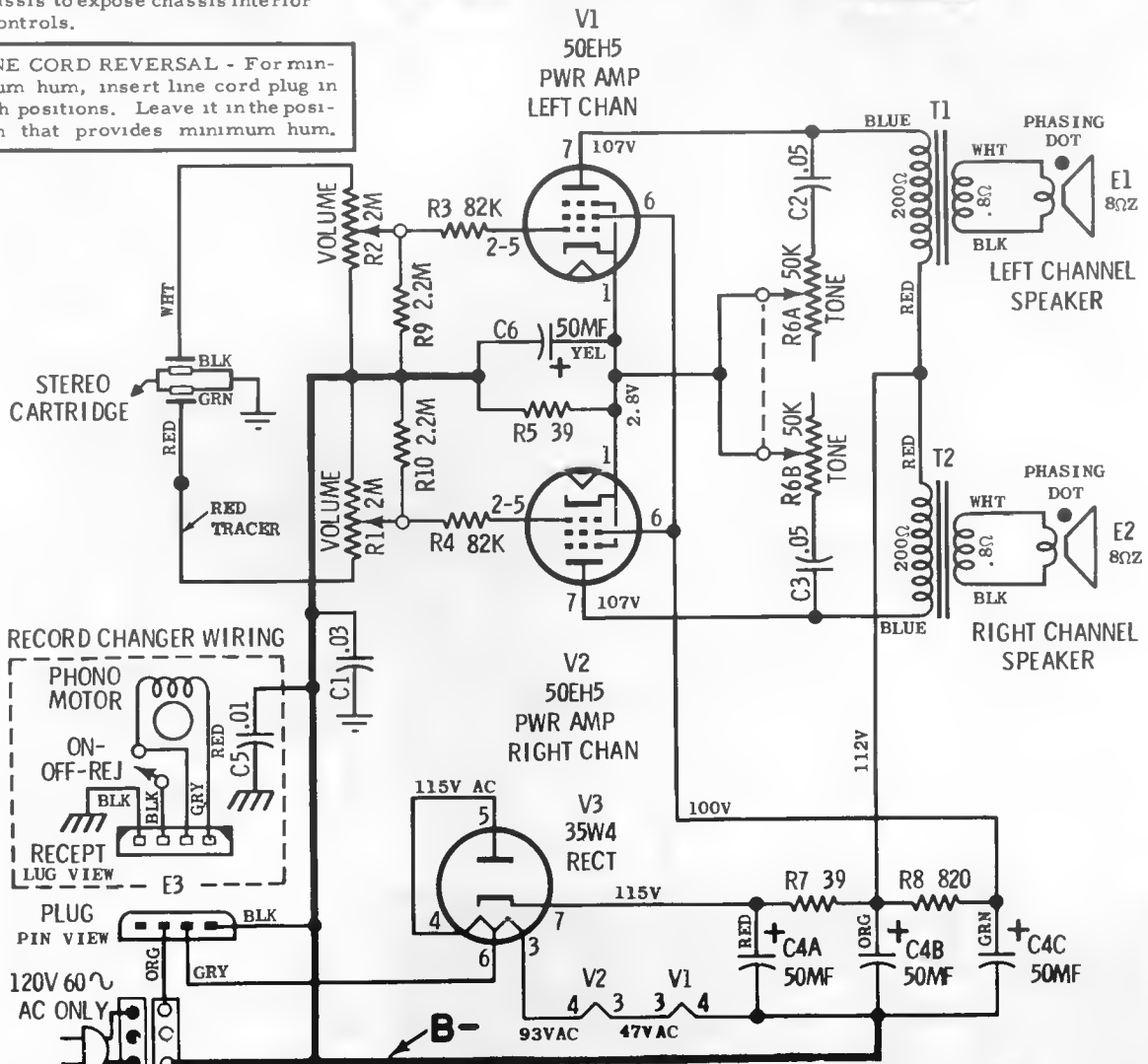

NOTES:

CAPACITORS - UNLESS OTHERWISE SPECIFIED, DECIMAL VALUES IN MF, ALL OTHERS IN MMF.

VOLTAGES - MEASURED FROM POINT INDICATED TO B- WITH A VTVM, ± 10% NO SIGNAL INPUT.

⊥ = CHASSIS GROUND

⊥ = RC GROUND

MOTOROLA MODELS SP52, SP511 CHASSIS HS-1135

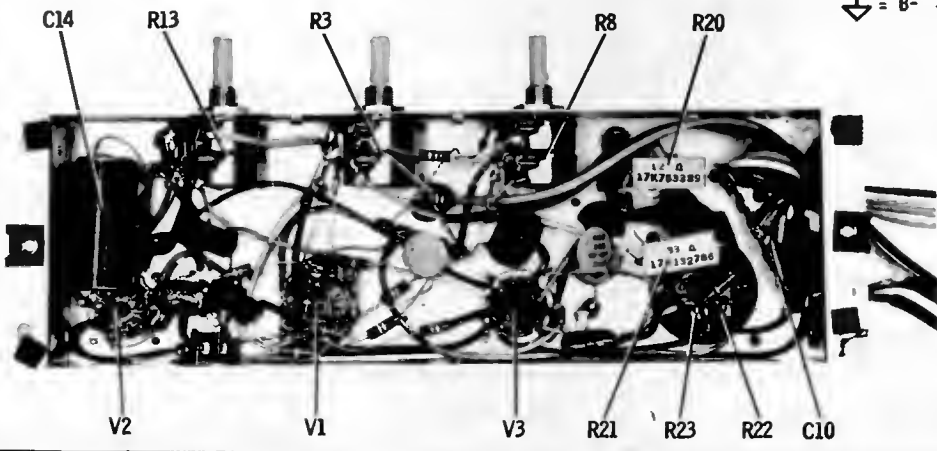
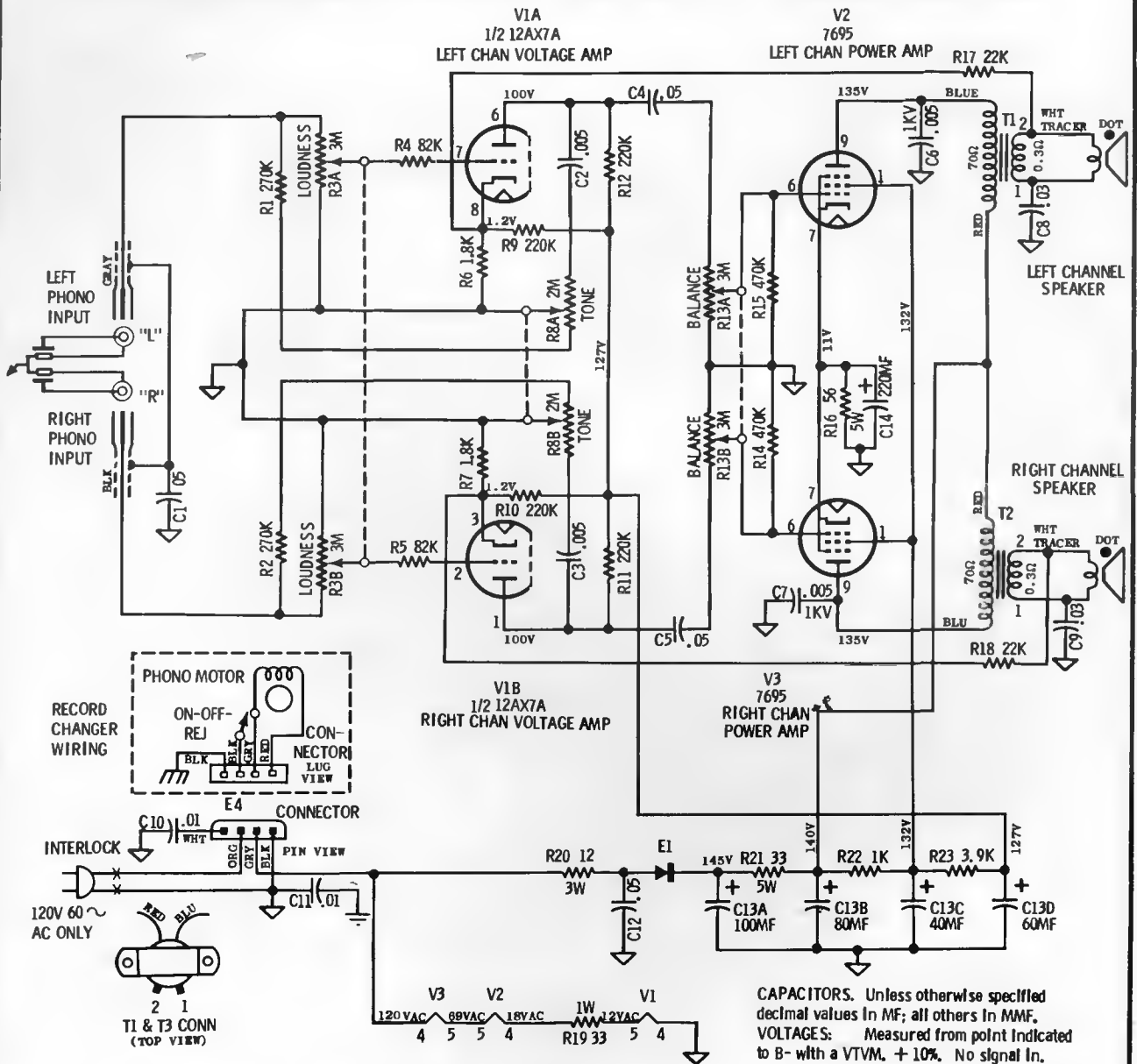

PARTS LOCATION

MOTOROLA

MODELS HK53-1 (HS-1117), HK53-2 (HS-1123)

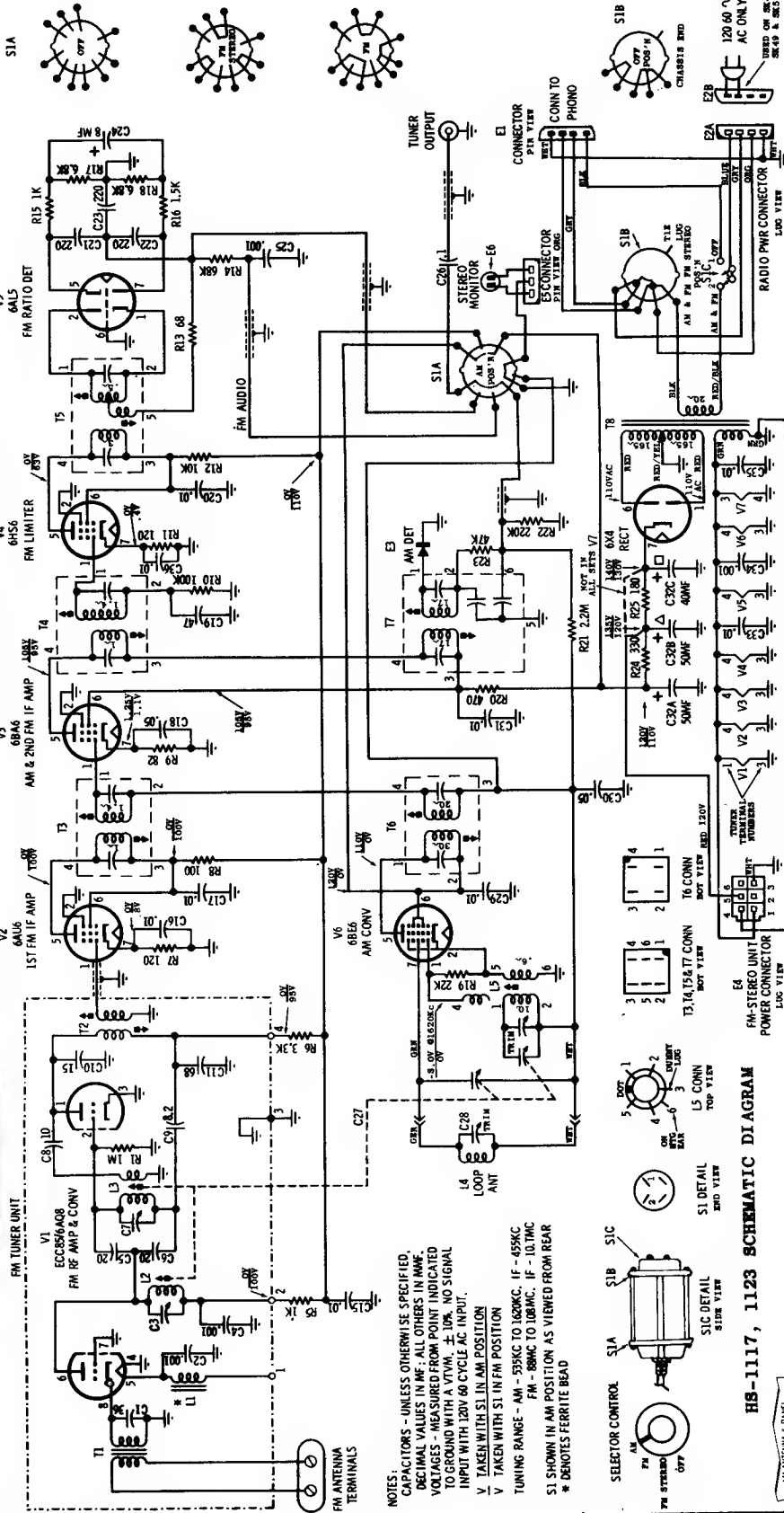

NOTES:
 CAPACITORS - UNLESS OTHERWISE SPECIFIED, DECIMAL VALUES IN MF; ALL OTHERS IN MMF. VOLTAGES - MEASURED FROM POINT INDICATED TO GROUND WITH A VTVM, ± 10%, NO SIGNAL INPUT WITH 120V 60 CYCLE AC INPUT.
 V TAKEN WITH S1 IN AM POSITION
 V TAKEN WITH S1 IN FM POSITION
 TUNING RANGE - AM - 530KC TO 1600KC. IF - 455KC
 FM - 88MC TO 108MC. IF - 10.7MC
 S1 SHOWN IN AM POSITION AS VIEWED FROM REAR
 * DENOTES FERRITE BEAD

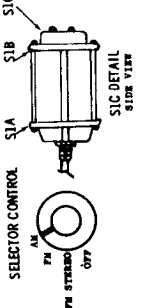

HS-1117, 1123 SCHEMATIC DIAGRAM

(This tuner is used in various combinations)

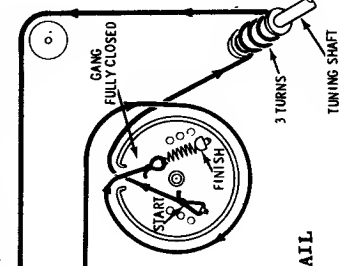
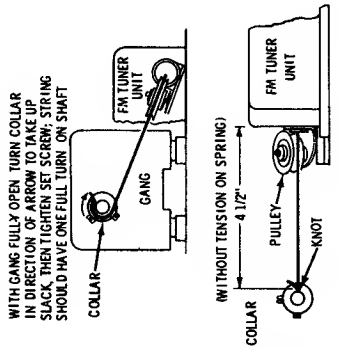

DIAL STRINGING DETAIL

WITH GANG FULLY OPEN TURN COLLAR IN DIRECTION OF ARROW TO TAKE UP SLACK. THEN TIGHTEN SET SCREW; STRING SHOULD HAVE ONE FULL TURN ON SHAFT.

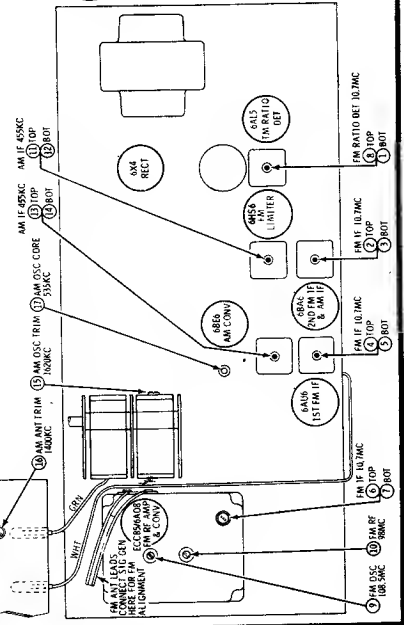

ALIGNMENT LOCATION DETAIL

MOTOROLA Model HK54-2, Chassis HS-996,
used in various FM-Stereo combinations

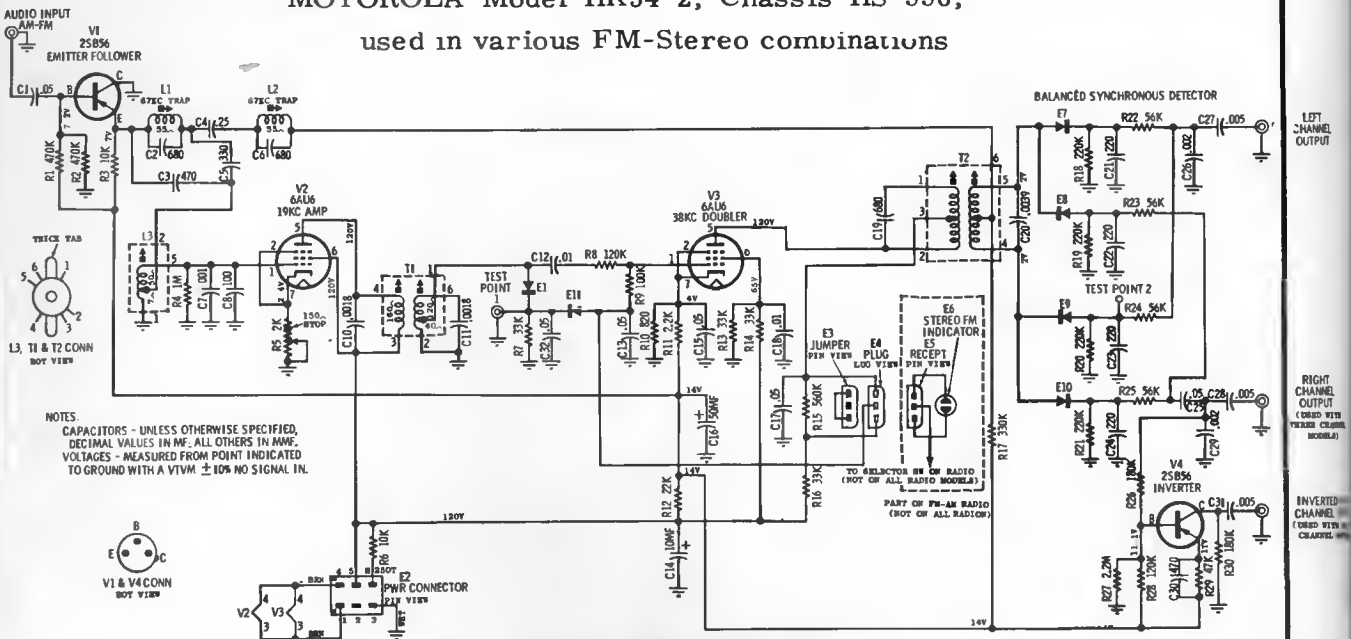

HS-996AB SCHEMATIC DIAGRAM

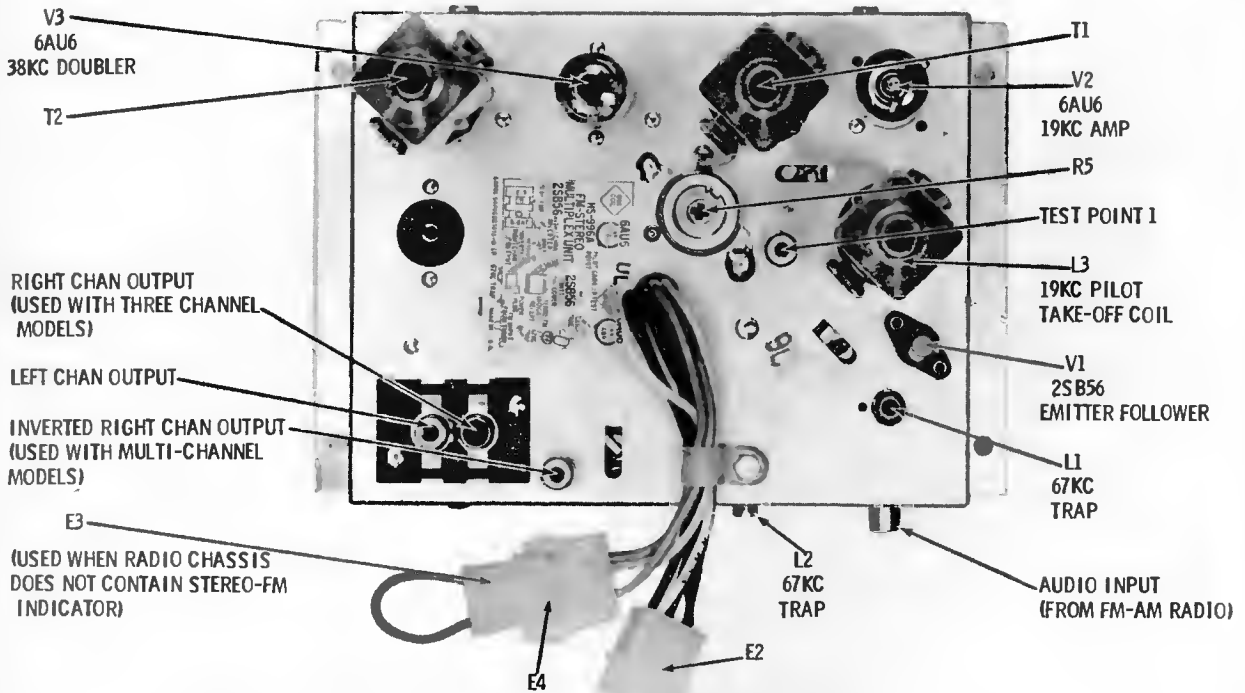

METHOD ALIGNMENT OF HK-54-2 USING AN FM-STEREO STATION AIR SIGNAL

NOTE: Storecast traps cannot be aligned using an air signal. A generator must be used for trap alignment.

19Kc Pilot Carrier Channel Alignment And 38Kc Frequency Doubler Adjustment

With stereo radio tuned to a good stereo-FM broadcast and output of radio applied to audio input jack of HK-54-2, proceed as follows:

1. Connect positive lead of VTVM to Test Point 1; negative lead to ground.
2. Adjust L-3 and primary and secondary of T-1 for maximum indication on VTVM.
3. Move VTVM to Test Point 2 and adjust T-2 primary and secondary for maximum meter indication.
4. Move VTVM to Test Point 1 and while monitoring this voltage, care-

fully adjust L-3 for maximum separation in left and right speakers on program material. This maximum separation point should be very near peak meter indications.

Adjustment of Sensitivity Control, R 5

The control should be set so that the stereo monitor lights on stereo signals but does not light on noise in between stations.

MOTOROLA

Chassis HS-1048 and HS-1050 used in Models SK-77-2, SK-78-1, SK-79-1, SK-111, SK-112, SK-115, SK-116.

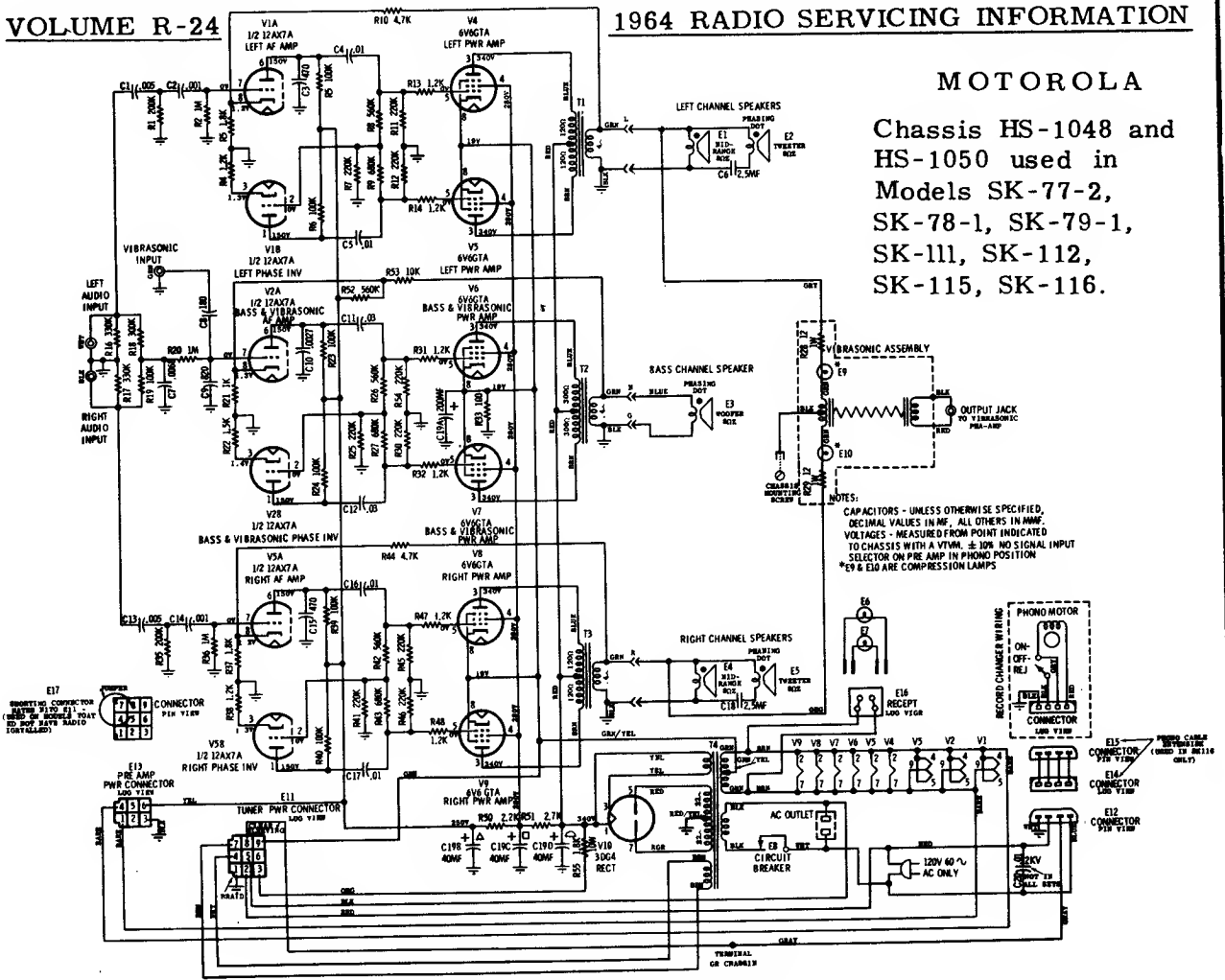

HS-1048 POWER AMP & POWER SUPPLY SCHEMATIC DIAGRAM

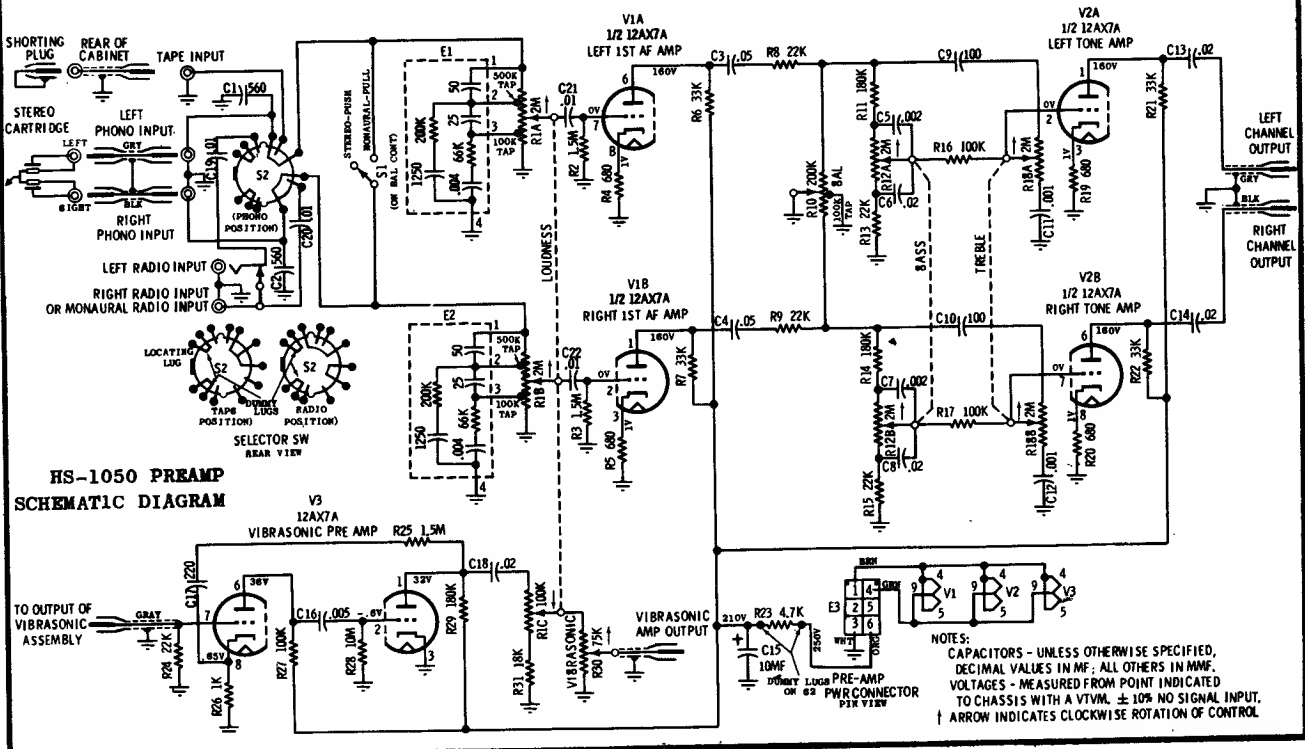

HS-1050 PREAMP SCHEMATIC DIAGRAM

VOLUME R-24, MOST-OFTEN-NEEDED 1964 RADIO SERVICING INFORMATION

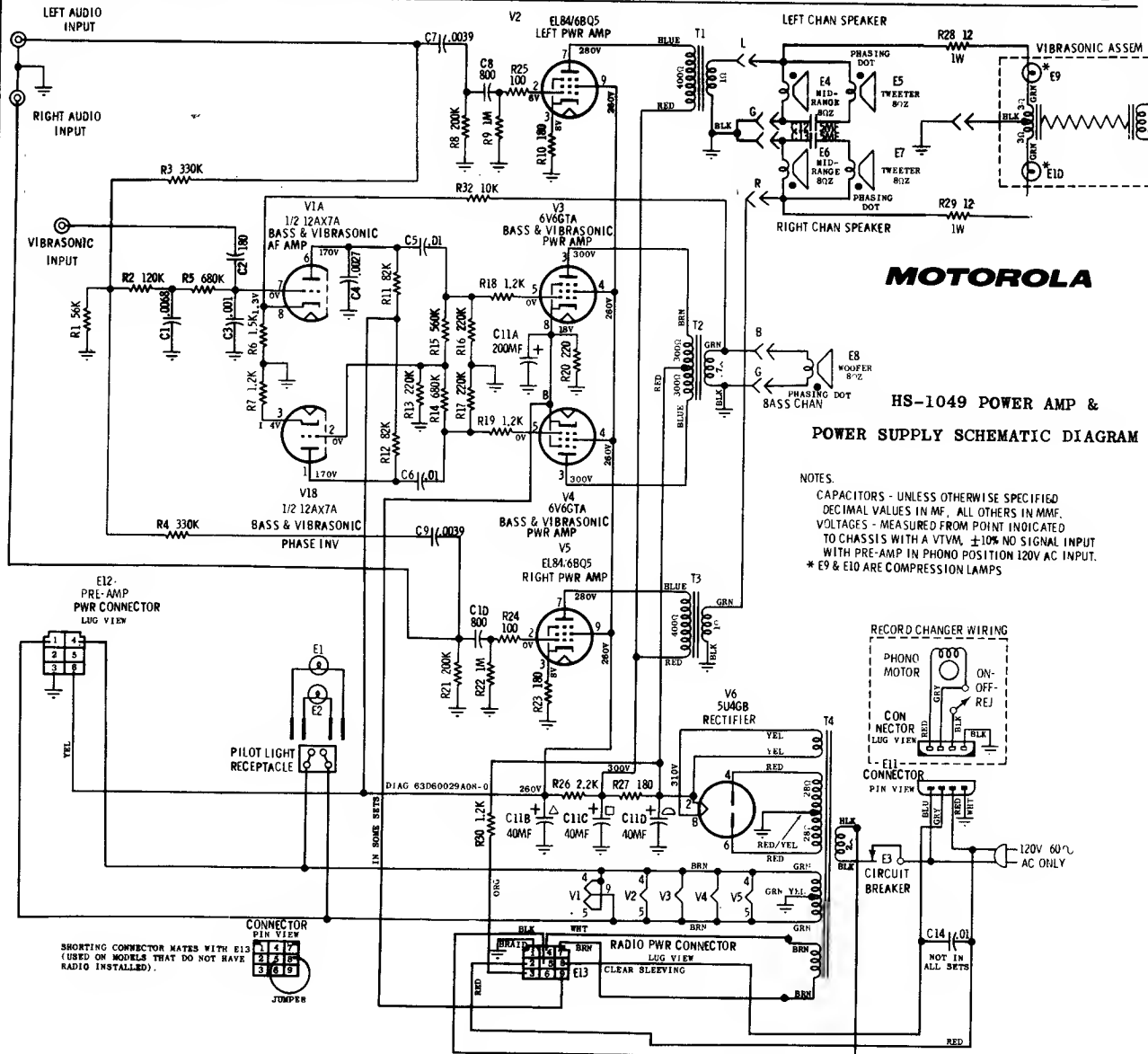

MOTOROLA

HS-1049 POWER AMP & POWER SUPPLY SCHEMATIC DIAGRAM

NOTES:
CAPACITORS - UNLESS OTHERWISE SPECIFIED DECIMAL VALUES IN MF, ALL OTHERS IN MMF. VOLTAGES - MEASURED FROM POINT INDICATED TO CHASSIS WITH A VTVM, ±10% NO SIGNAL INPUT WITH PRE-AMP IN PHONO POSITION 120V AC INPUT. * E9 & E10 ARE COMPRESSION LAMPS

Chassis HS-1049 with HS-1051 used in sets SK106, SK107, SK109, SK110.

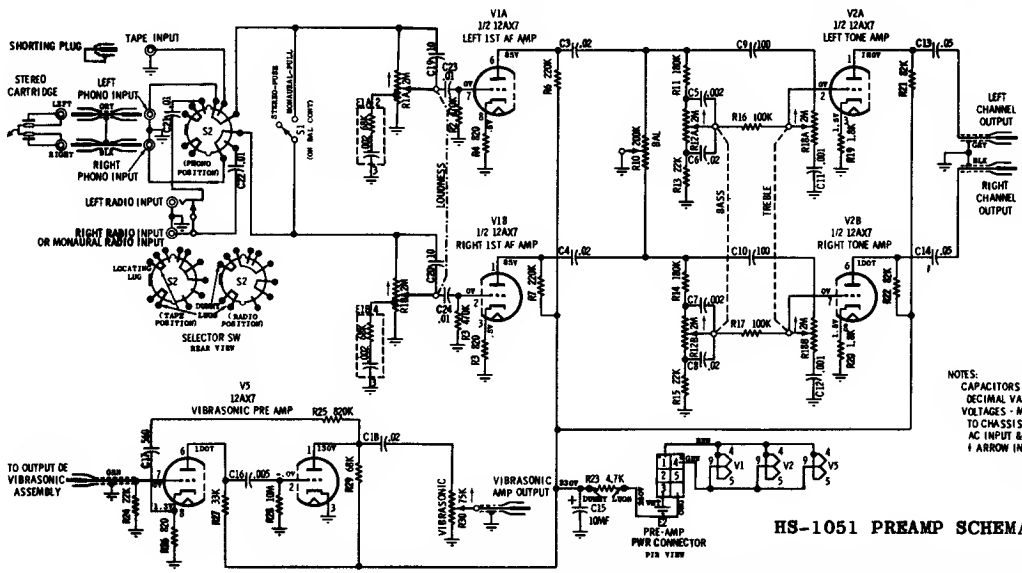

HS-1051 PREAMP SCHEMATIC DIAGRAM

NOTES:
CAPACITORS - UNLESS OTHERWISE SPECIFIED, DECIMAL VALUES IN MF; ALL OTHERS IN MMF. VOLTAGES - MEASURED FROM POINT INDICATED TO CHASSIS WITH A VTVM, ±10% WITH 120V AC INPUT & NO SIGNAL IN. S2 IN PHONO POSITION, ↑ ARROW INDICATED CLOCKWISE ROTATION OF CONTROL.

MOTOROLA MODELS SK100-4, SK124, SK125 CHASSIS HS-1201

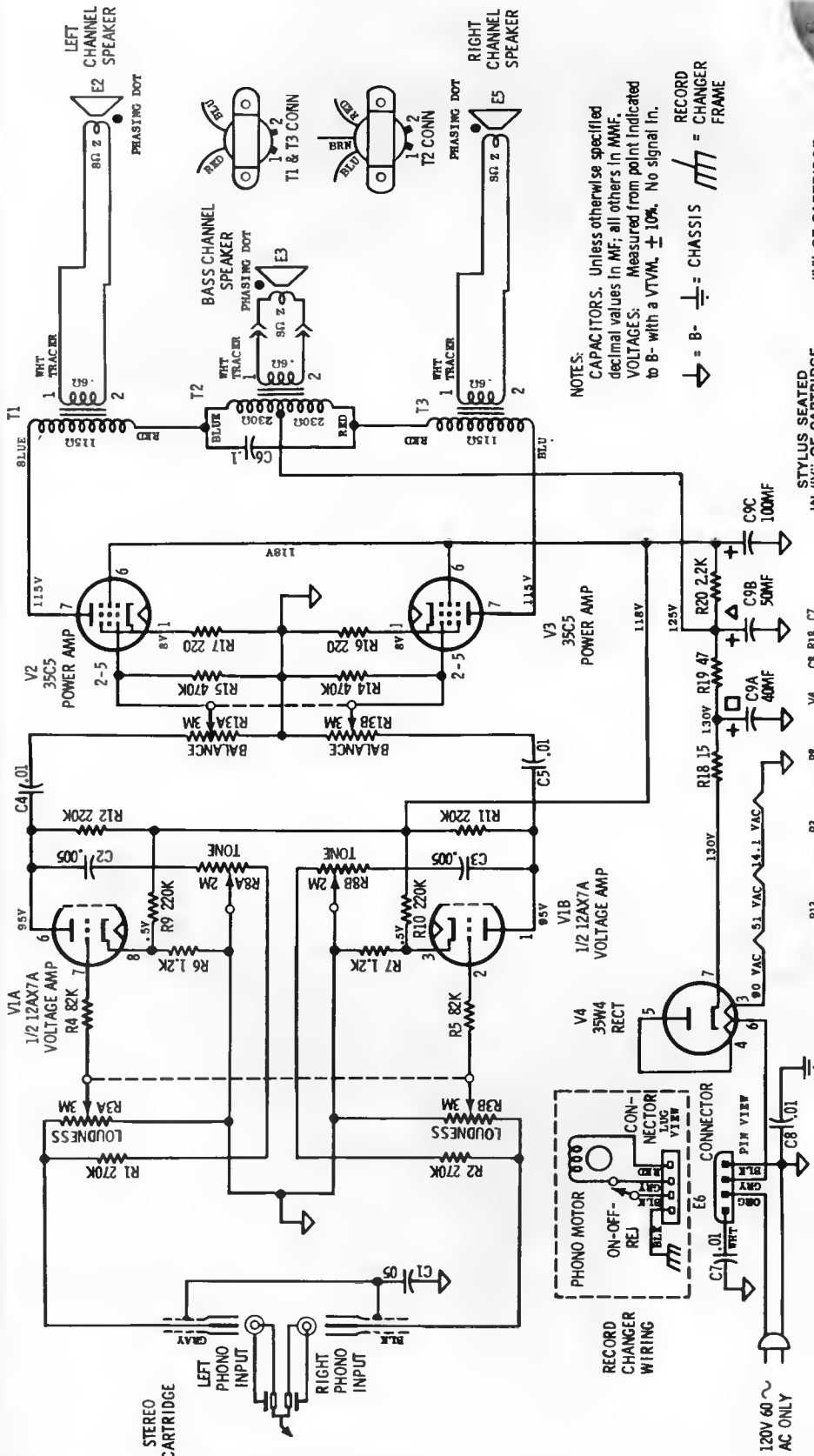

NOTES: CAPACITORS. Unless otherwise specified decimal values in MF; all others in MMF.
VOLTAGES: Measured from point indicated to B- with a VTVM, $\pm 10\%$. No signal in.

\rightarrow B- = CHASSIS
 = CHANGER FRAME
 = RECORD CHANGER FRAME

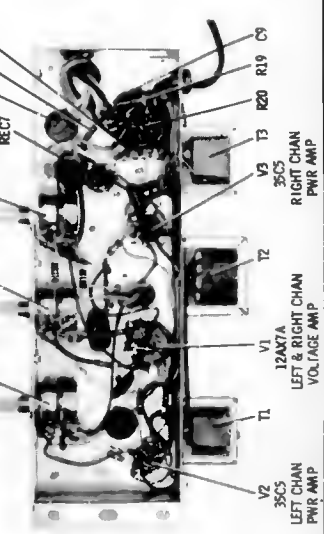
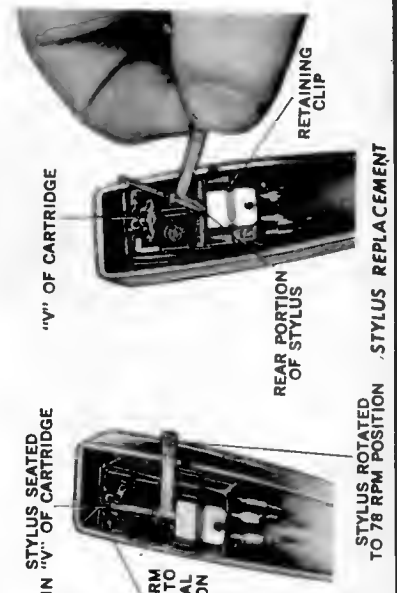

- ### CHASSIS REMOVAL
1. From bottom of cabinet, disconnect all leads and cables connected to chassis (on SK100-4, remove bottom panel first).
 2. From inside record changer compartment, remove 3 control knobs and loosen large hex nuts located under knobs; then grasp the chassis from bottom and loosen nuts completely.
 3. Remove chassis from cabinet.

VOLUME R-24, MOST-OFTEN-NEEDED 1964 RADIO SERVICING INFORMATION

MOTOROLA Models SK103, SK104, SK105, SK108, Chassis HS-1055, HS-1102

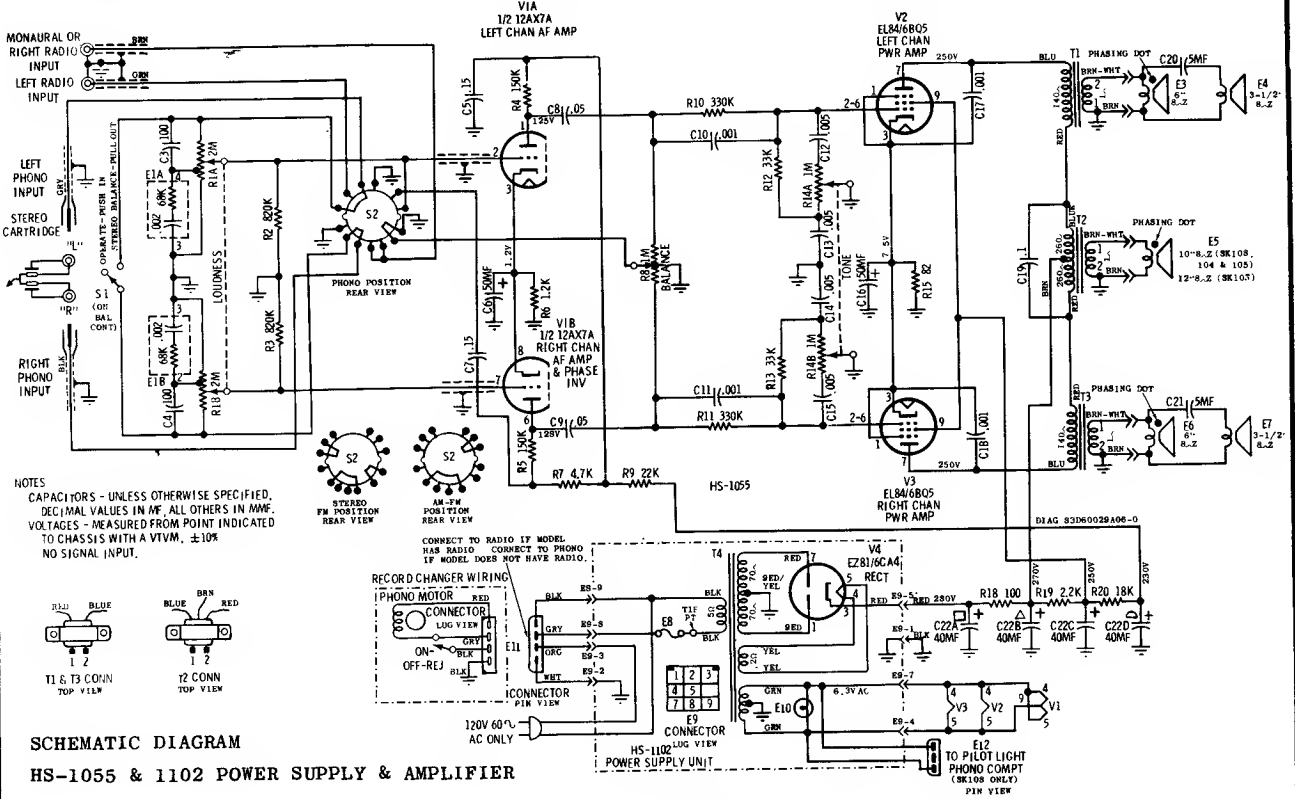

MOTOROLA
Model SP41, Chassis HS-1059

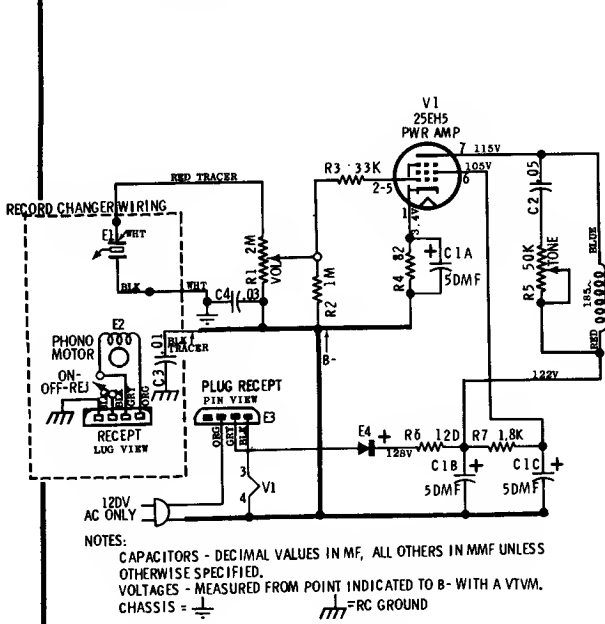

MOTOROLA Models SP42, SP43,
Chassis HS-1061

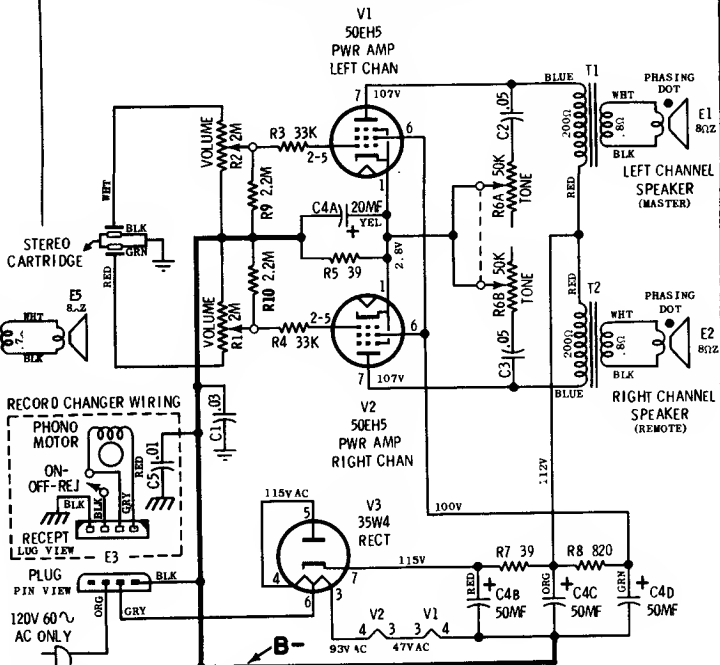

MOTOROLA MODEL SK119 CHASSIS HS-1192

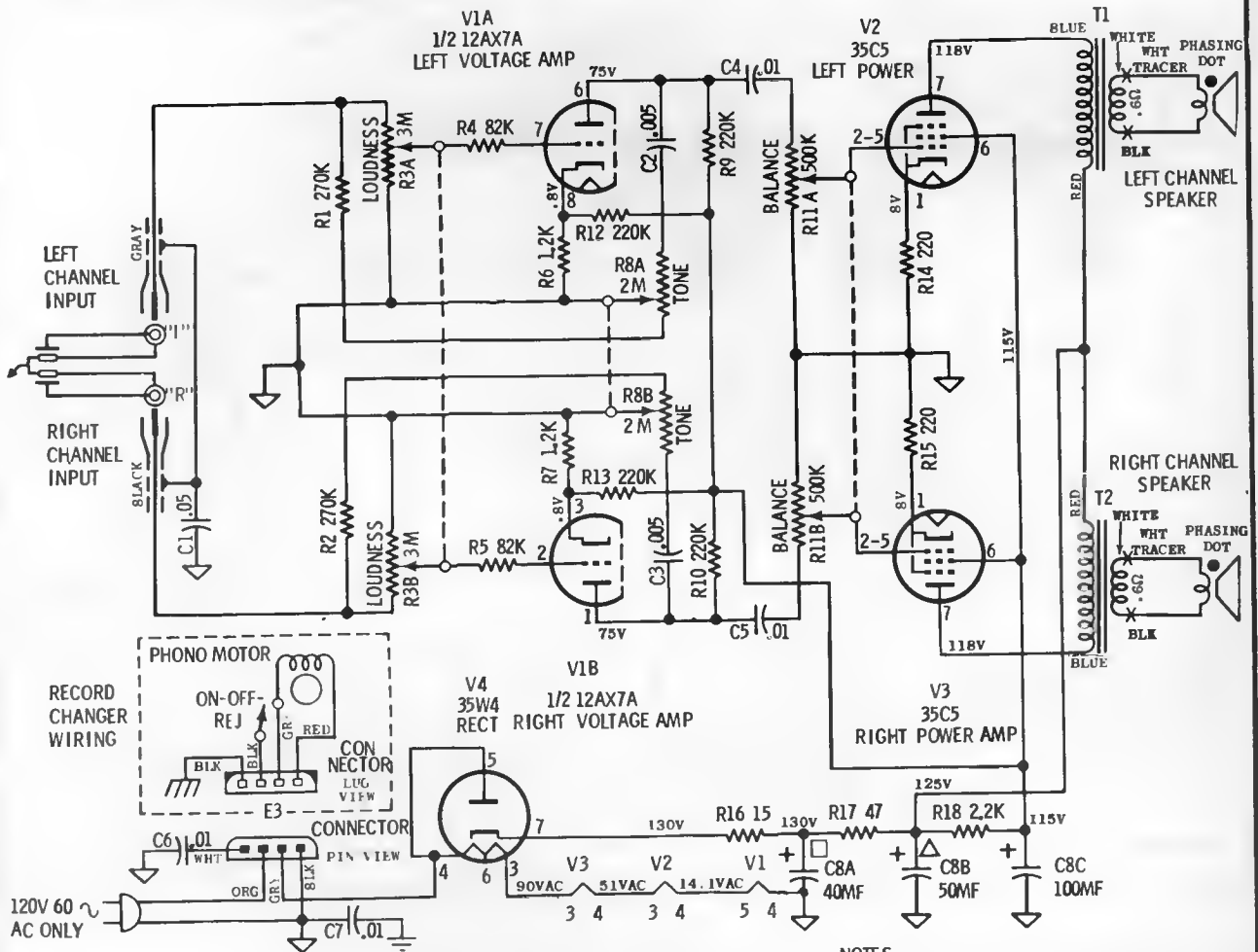

CHASSIS REMOVAL

1. From bottom of cabinet, disconnect all leads and cables connected to chassis.
2. From inside record changer compartment, remove 3 control knobs and loosen large hex nuts located under knobs; then grasp chassis from bottom and loosen nuts completely.
3. Remove chassis from cabinet.

RECORD CHANGER REMOVAL

1. Turn the 2 changer mounting screws clockwise until they are flush with the changer base.
2. From underside of changer, disconnect all cables from record changer.
3. Turn the mounting clips located at the ends of the mounting screws so they are parallel with the mounting screws, then lift changer out of cabinet.

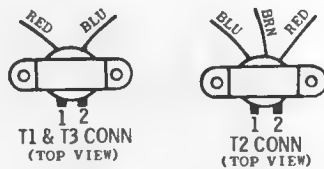

NOTES:

CAPACITORS - Unless otherwise specified decimal values in MF; all others in MMF.
 VOLTAGES - Measured from point indicated to B- with a VTVM, +10%. No signal in.

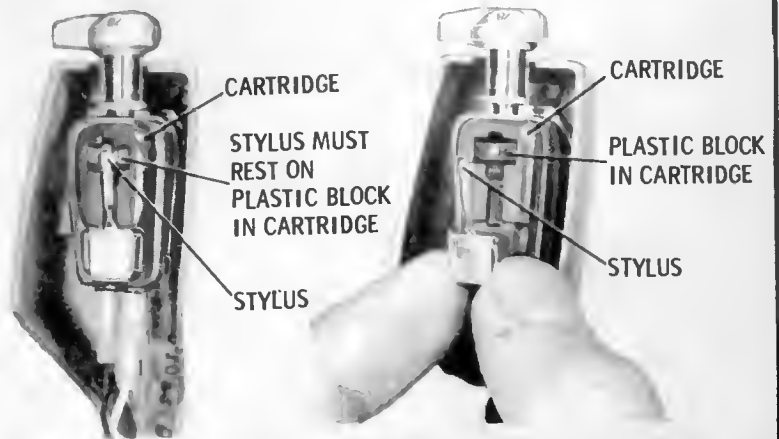
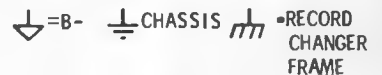

STYLUS REPLACEMENT

MOTOROLA
Model SP44, Chassis HS-1058

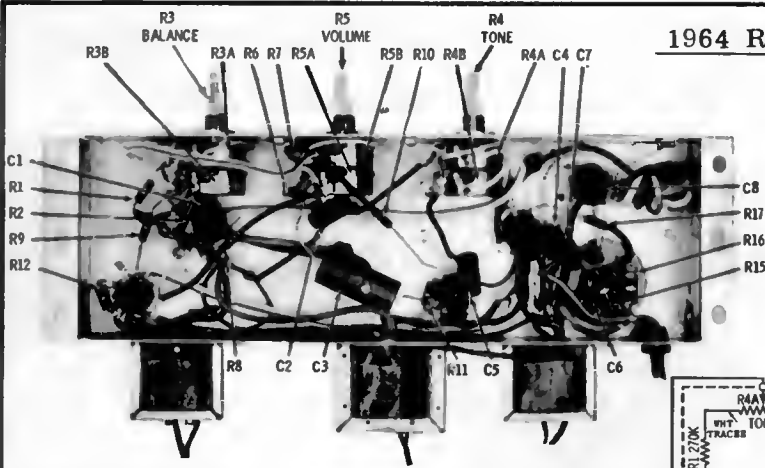

HS-1058 CHASSIS
PARTS LOCATION

HS-1058 SCHEMATIC DIAGRAM

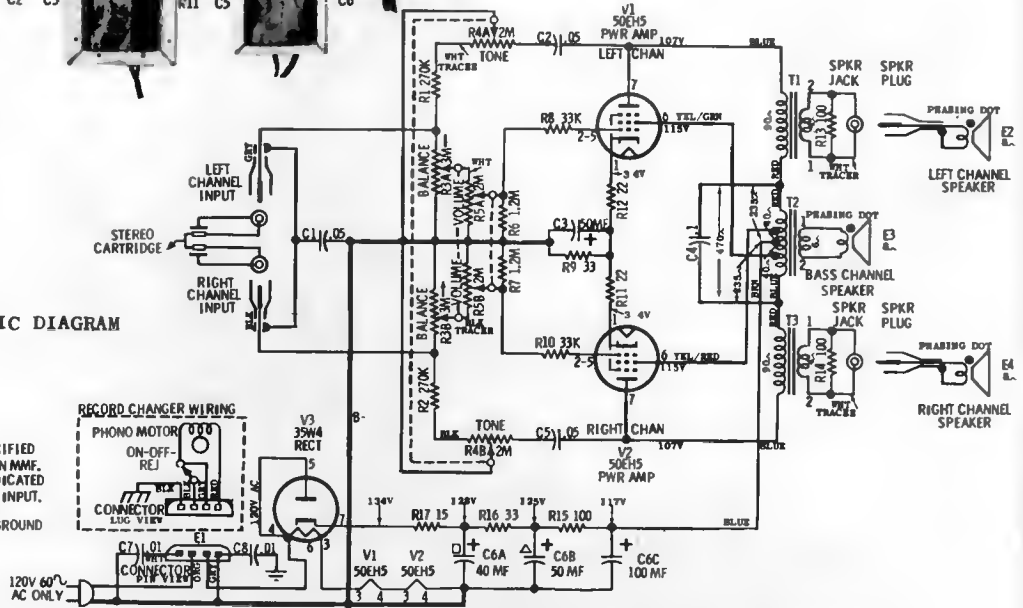

MOTOROLA Model SP44-1, Chassis HS-1125

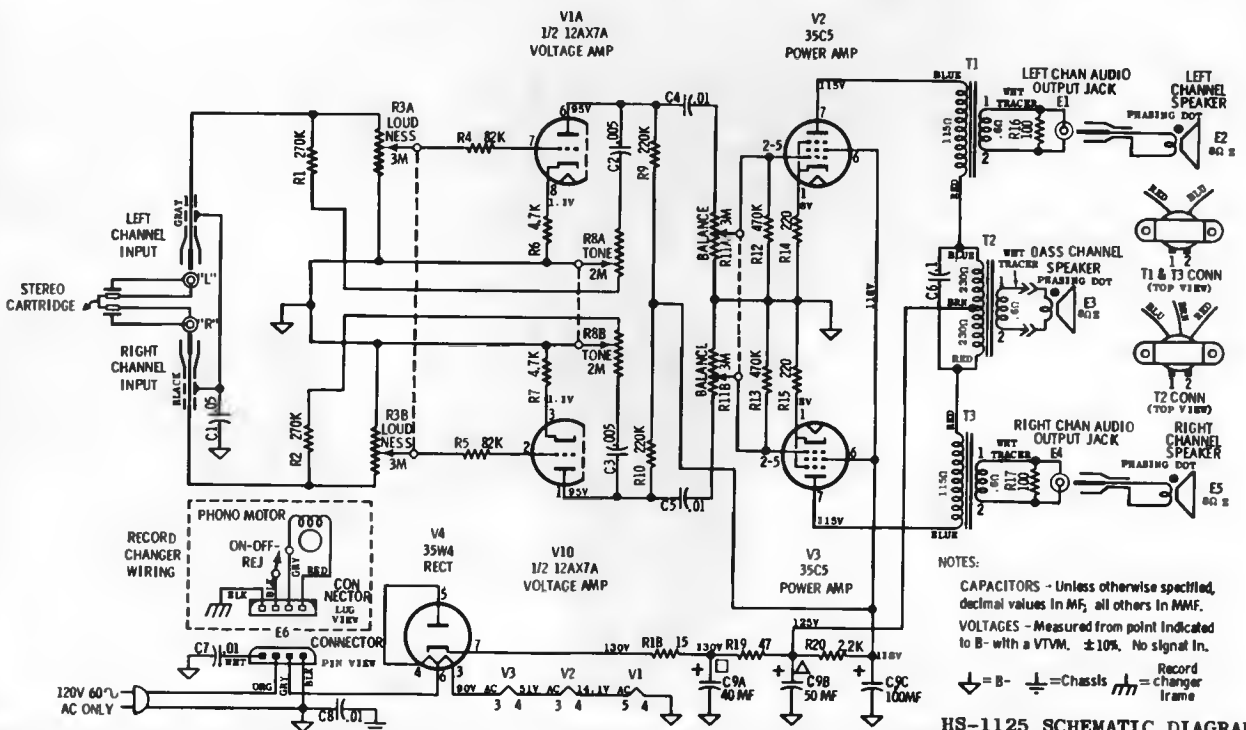

HS-1125 SCHEMATIC DIAGRAM

Packard Bell

Model RC-1S, using Chassis 8HF1 or 8HF2
(Continued on the next page)

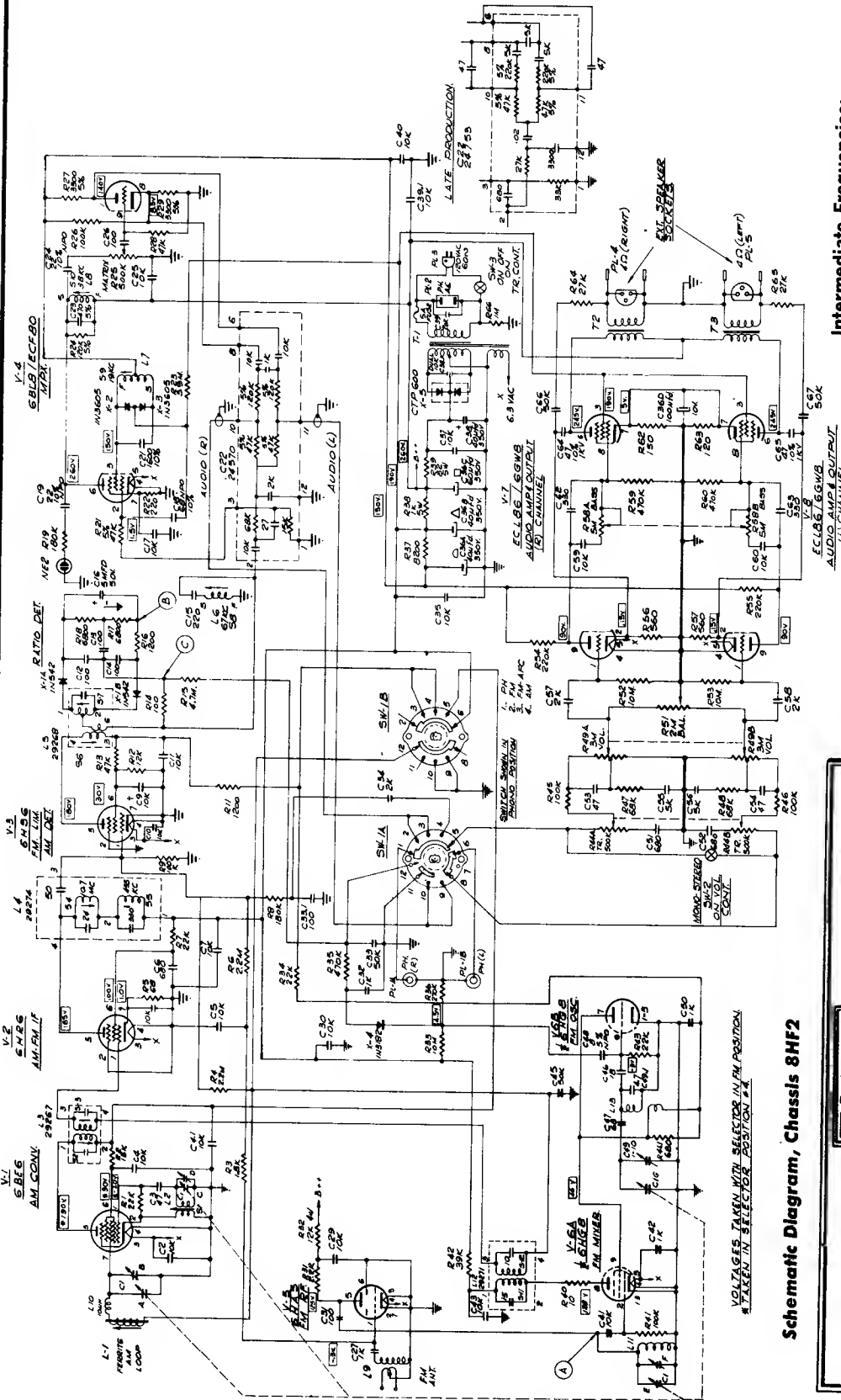

Intermediate Frequencies:
AM Radio: 455 kc
FM Radio: 10.7 mc

Model RC-1S contains either chassis 8HF1 or chassis 8HF2. These chassis are similar, each being an AM/FM radio receiver with built-in multiplex circuitry. The major difference between the 8HF1 and 8HF2 is that the tube types of V-5 and V-6 differ, along with the associated circuitry. See schematics for details of differences.

Schematic Diagram, Chassis 8HF2

VOLTAGES TAKEN WITH SELECTOR IN FM POSITION
* TAKEN IN SELECTOR POSITION 24

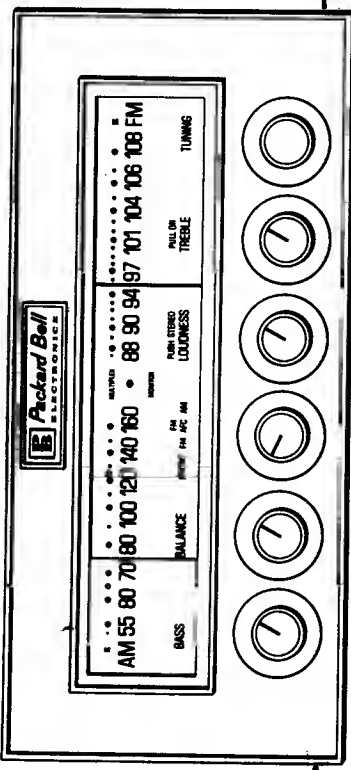

Control Panel, Model RC-1S

Packard Bell

Model RC-1S, Chassis 8HF1 or 8HF2
(Continued from preceding page)

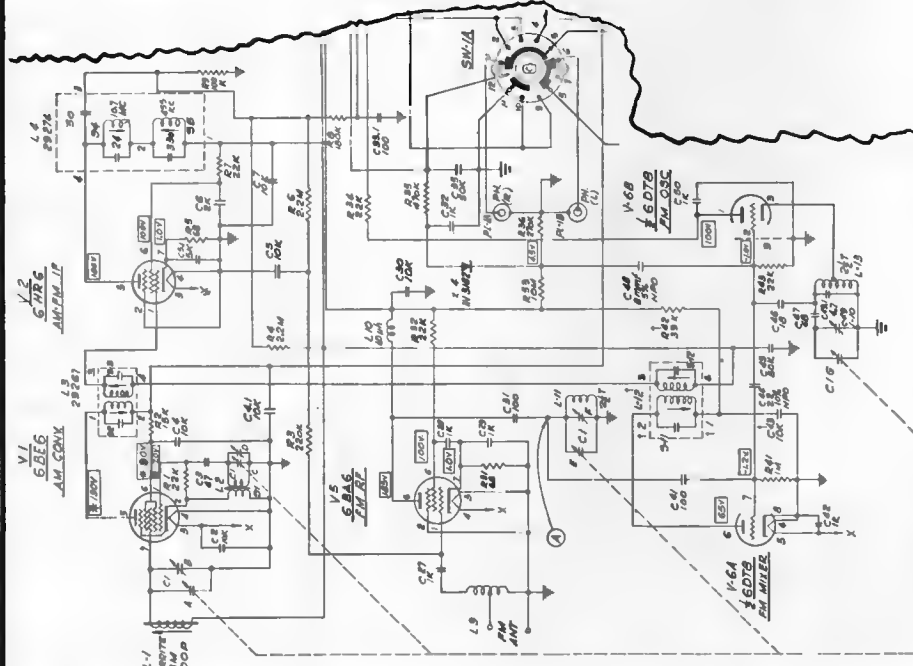
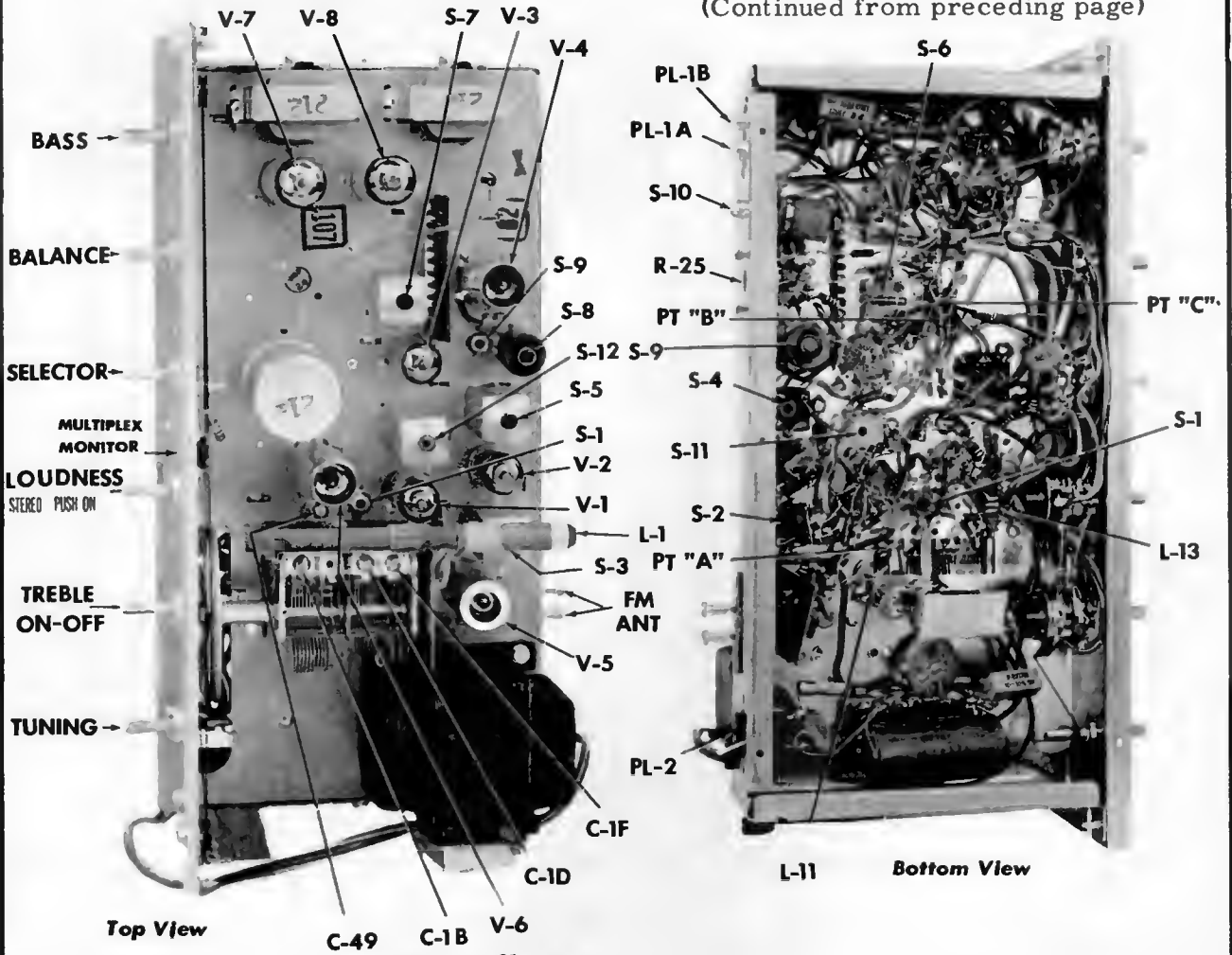

Partial diagram of Chassis 8HF1, showing differences from 8HF2.

PRODUCTION MODIFICATION ON 8HF1
 Capacitors C-9 and C-43 were changed from 2000 mmf to 10,000 mmf.
 Resistor R-42 was changed from 220,000 ohms to 39,000 ohms.
 Chassis stamped with the number 4104 (or a higher number) contain the production modification described above.
MARKING FOR 8HF2 CHASSIS:
 Models containing chassis 8HF2 are stamped with the number 4116.

PHILCO

TRANSISTOR PORTABLE MODEL T-67

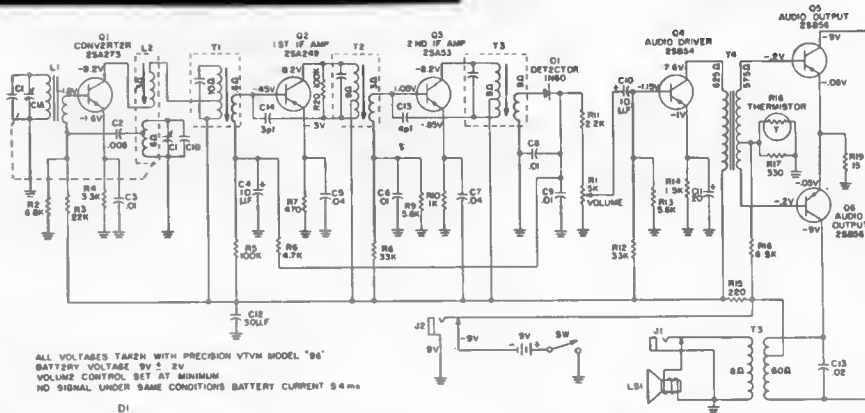

ALL VOLTAGES TAKEN WITH PRECISION VTVM MODEL '86'
BATTERY VOLTAGE 9V 2V
VOLUME CONTROL SET AT MINIMUM
NO SIGNAL UNDER SAME CONDITIONS BATTERY CURRENT 5.4 ma

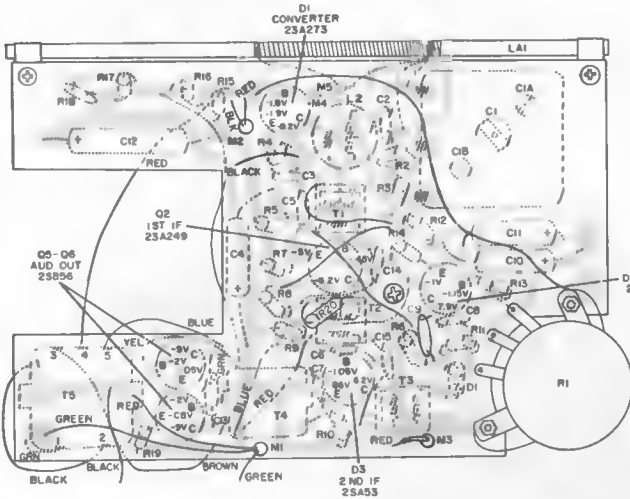

PANEL REMOVAL - To remove panel from cabinet, lift out jack assembly and remove screw in panel located at D5 (see graph). Panel may now be lifted out; speaker will remain in cabinet.

Foil Side of Perma-Circuit Panel

ALIGNMENT: Allow the test equipment at least 15 minutes to warm up before starting the alignment procedure. Connect an a-c VTVM or oscilloscope across the speaker voice coil. Use an AM R-F signal generator connected as indicated in chart. Keep generator output low enough to prevent A.G.C. overload.

ALIGNMENT CHART

STEP	SIGNAL GENERATOR		RADIO		
	CONNECTION TO RADIO	DIAL SETTING	DIAL SETTING	SPECIAL INSTRUCTIONS	ADJUST
1	Use radiating loop (see note 1 below)	455KC	1600KC gang fully open	Adjust for maximum output in order given	T3-3rd I-F T2-2nd I-F T1-1st I-F
2	Same as Step 1	540KC	540KC	Adjust for maximum output. Adjust L1 by sliding coil on core and waxing into position of maximum output. Rock tuning gang while adjusting L2.	L2-osc. L1-ant. coil
3	Same as Step 1	1600KC	1600KC	Adjust for maximum output.	C1A-ant. trimmer
4	Same as Step 1	1400KC	1400KC	Adjust for maximum output.	C1B-osc. trimmer
5	Repeat last three steps.				

NOTE 1: Use a 6 to 8 turn, 6-inch diameter loop made up of insulated wire. Connect to generator terminals and loose couple to radio antenna.

PHILCO Transistor Portable Model T-68

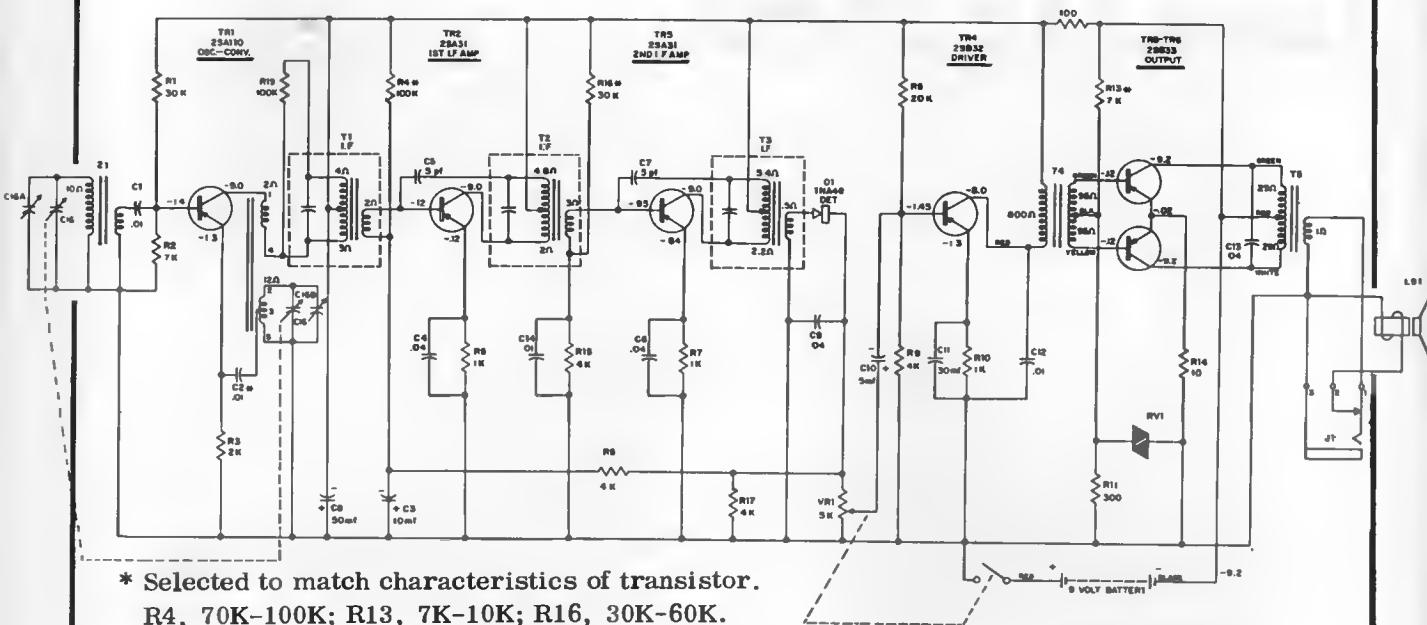

* Selected to match characteristics of transistor.
 R4, 70K-100K; R13, 7K-10K; R16, 30K-60K.

I. F. 455 KC.

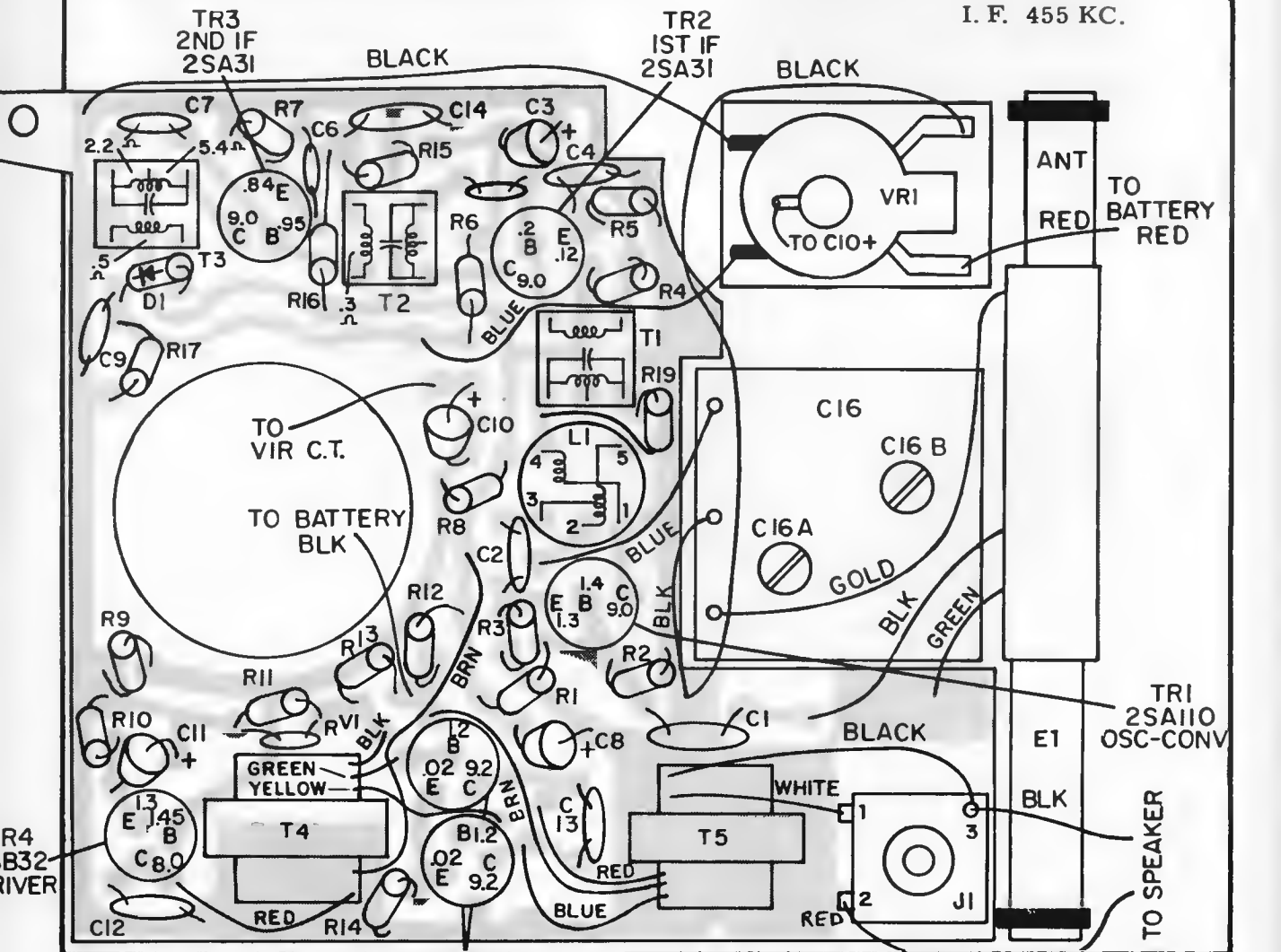

TR5-TR6
 OUTPUT
 2SB33

PHILCO

PORTABLE TRANSISTOR RADIO — MODEL T-84

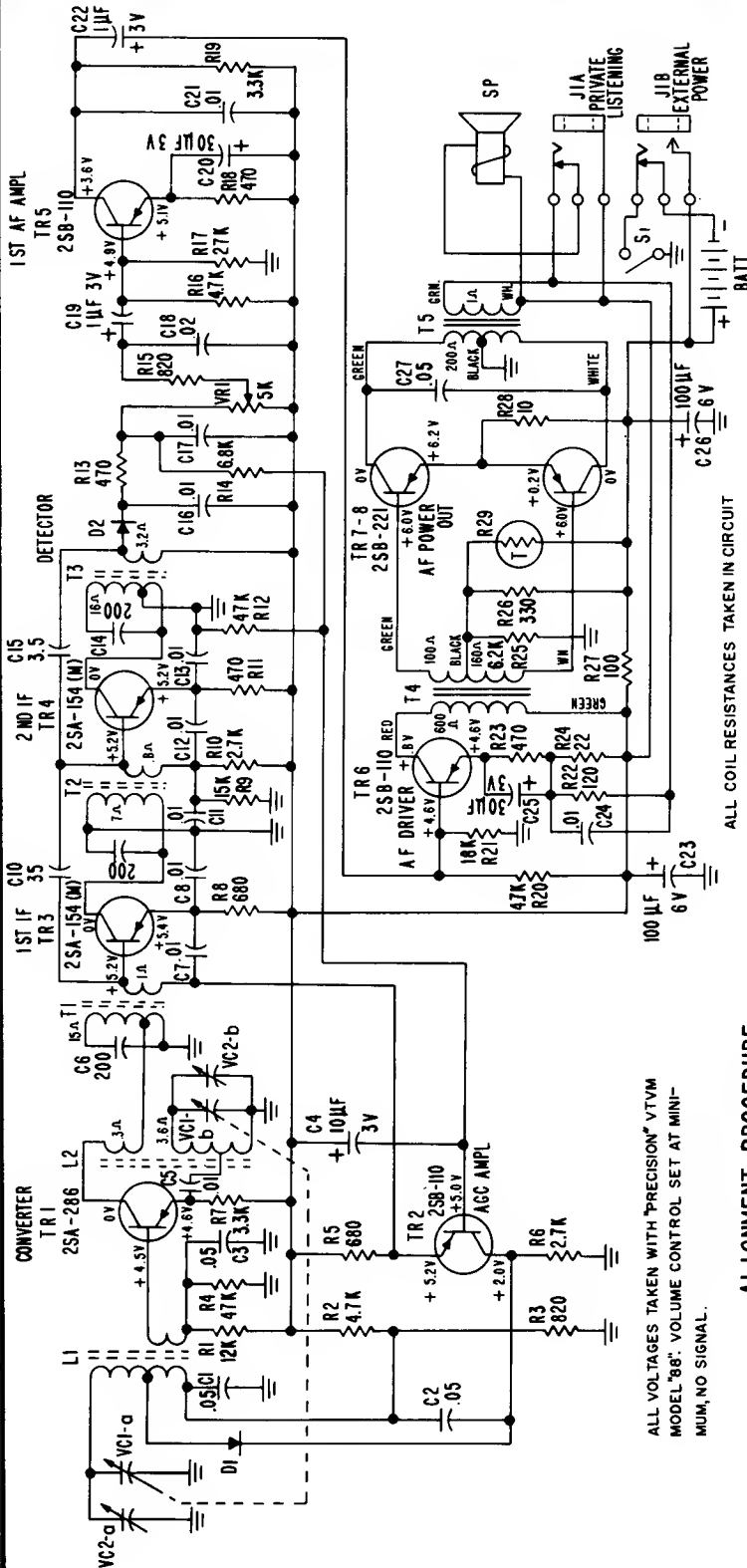

ALL VOLTAGES TAKEN WITH "PRECISION" VTVM MODEL "86". VOLUME CONTROL SET AT MINIMUM, NO SIGNAL.

ALL COIL RESISTANCES TAKEN IN CIRCUIT

ALIGNMENT PROCEDURE

Allow the test equipment at least fifteen (15) minutes to warm up before starting the alignment procedure. Connect an a-c VTVM or oscilloscope across the speaker voice coil. Use an AM-R-F signal generator connected to a test loop placed in close proximity to the receiver antenna. Keep generator output low enough to prevent A.V.C. overload. Set volume at maximum.

STEP	SIGNAL GENERATOR SETTING	DIAL INDICATOR SETTING	ADJUST FOR MAX. OUTPUT
1	455KC	Quiet point near 1600KC	I-F transformers T3, T2, T1
2	1600KC	1600KC	CV2-b (osc. trimmer)
3	1400KC	1400KC	CV2-a (RF trimmer)
4	540KC	540KC	L2 (osc. -slug)
5	600KC	600KC	L1 (ant.)
6	Repeat steps 2, 3, 4 and 5.		

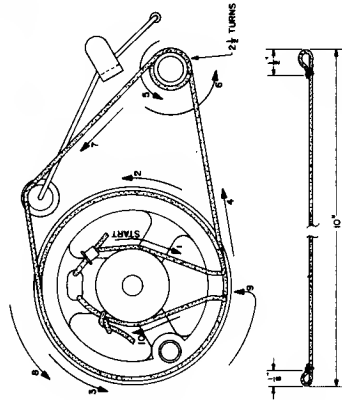

Dial Cord - Model T-84

PANEL REMOVAL -

The complete panel, tuning dial and knob assembly is removed by extracting three Philco lips head screws located as follows: 1 - single screw on right end of panel (viewing from rear); 2 - screw holding metallic mounting assembly tab located between volume control knob and tuning dial; 3 - screw holding metallic mounting assembly tab located between tuning knob and case bottom. Note that it is advisable to slide the external power jack free of the cabinet to prevent strain on the connecting leads.

PORTABLE TRANSISTOR RADIO — MODEL T-84

PHILCO

(Continued on the next page, at right)

TRANSISTOR PORTABLE MODEL T-81

Panel Removal - To remove panel from cabinet, remove three Phillips head screws located at A1, C9 and G1 (see bottom component location view). Panel and jack assembly may now be lifted out simultaneously. The speaker will remain in the cabinet. Jack assembly and panel may not be removed separately. They must be removed together. Remove jack assembly by prying up side of jack assembly toward front of radio.

BATTERY SUPPLY - One 9 volt type 216 battery. Special receptacle provided for connecting a line connected power supply. Special receptacle automatically disconnects internal battery with use of external supply.

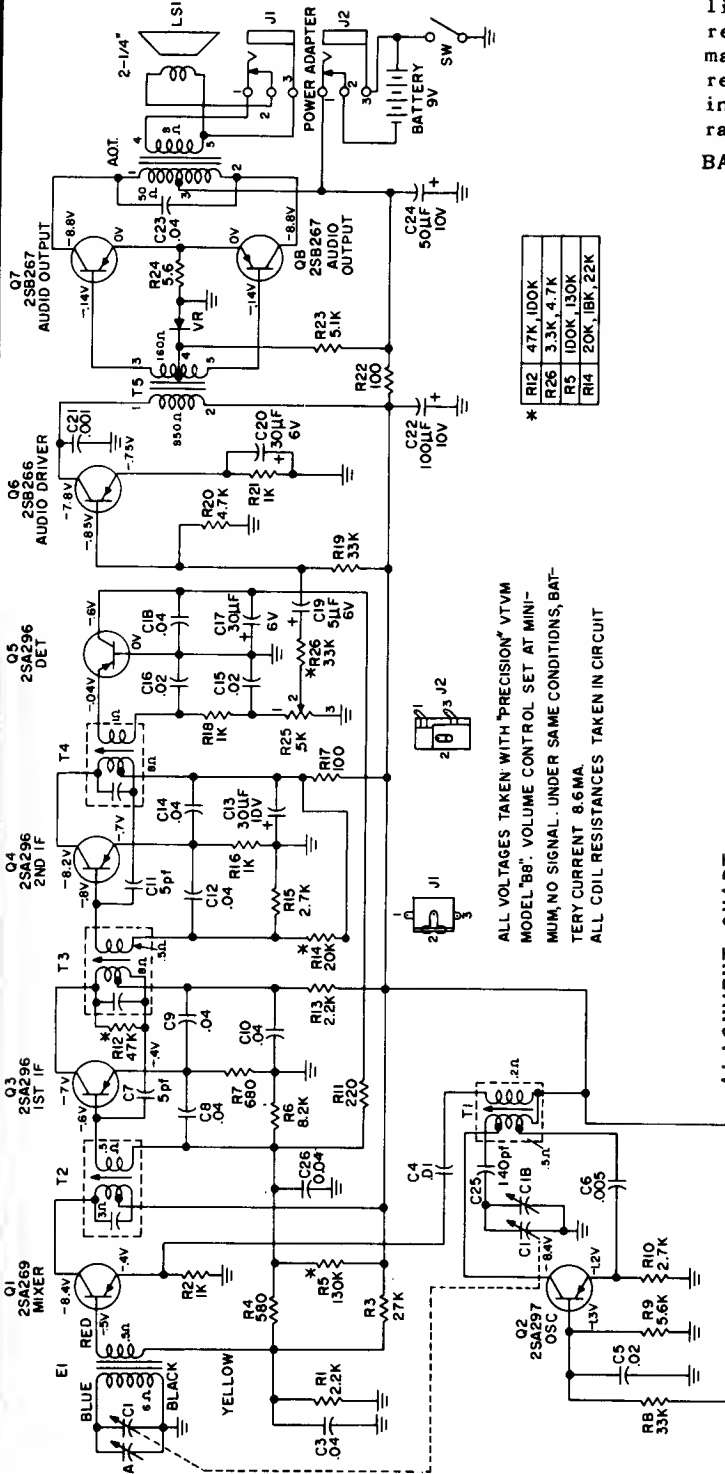

- * R12 47K, 100K
- R26 3.3K, 4.7K
- R5 100K, 130K
- R14 20K, 10K, 22K

ALL VOLTAGES TAKEN WITH "PRECISION" VTVM MODEL "88". VOLUME CONTROL SET AT MINIMUM, NO SIGNAL. UNDER SAME CONDITIONS, BATTERY CURRENT 8.6 MA. ALL COIL RESISTANCES TAKEN IN CIRCUIT

ALIGNMENT CHART

SIGNAL GENERATOR		RADIO		
STEP	CONNECTION TO RADIO	DIAL SETTING	SPECIAL INSTRUCTIONS	ADJUST
1	To base of mixer, Q1 through a .01 μfd cap.	455KC	Adjust for max. output in order given.	T4-3rd I-F T3-2nd I-F T2-1st I-F
2	Radiating loop (See Note below)	600KC	Adjust for max. output.	T1-osc.
3	Radiating loop	1500KC	Adjust for max. output.	C1B-osc. trimmer
4	Repeat steps 2 and 3 until no further improvement is obtained.			
5	Radiating loop	600KC	Adjust for max. output by sliding ant. coil on core.	E1 - antenna
6	Radiating loop	1500KC	Adjust for maximum output.	C1A - ant. trimmer
7	Repeat steps 5 and 6 until no further improvement is obtained.			

Note: For radiating loop, use a 6 to 8 turn, 6-inch diameter loop made up of insulated wire. Connect to generator terminals and place about one foot from antenna coil.

PHILCO
MODEL T-81

(Continued from preceding page at left)

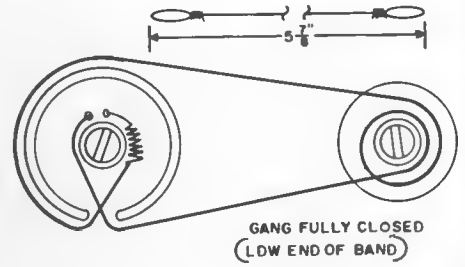
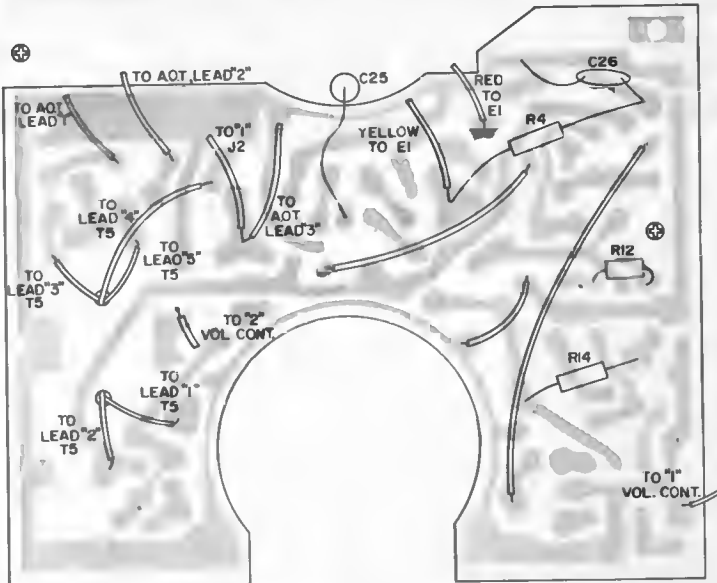

Foil Side of Perma-circuit Panel,
Bottom Component Location

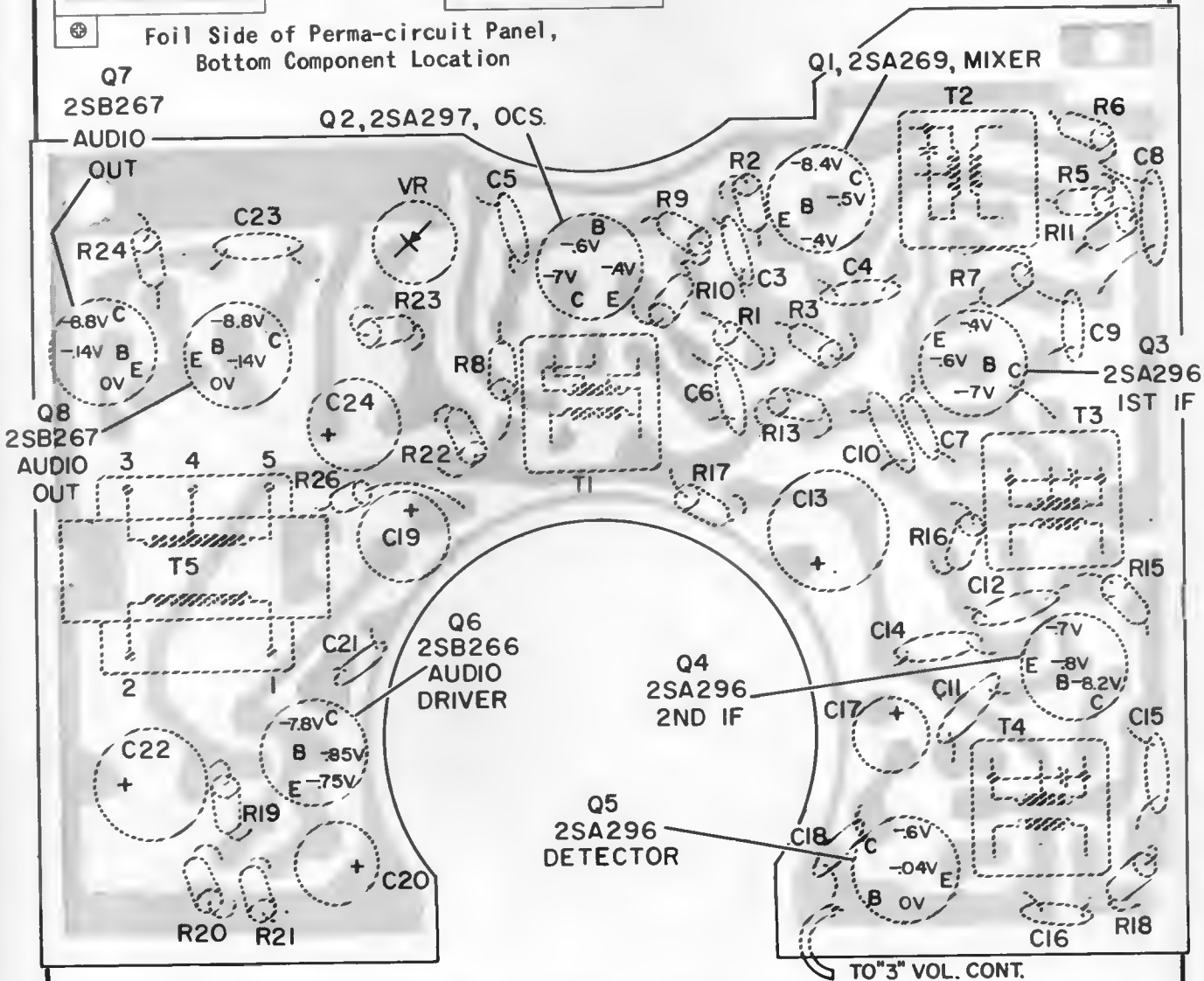

Foil Side of Perma-circuit Panel, Top Component Location

PHILCO

TRANSISTOR PORTABLE MODEL T-90

FREQUENCY COVERAGE: 520KC to 1650KC
 INTERMEDIATE FREQUENCY: 455KC
 ANTENNA: Self-contained ferrite loop
 SPEAKER: 2-3/4 inch PM 10 ohms V.C. impedance. Jack provided for optional private listening attachment.
 BATTERY SUPPLY: 4 penlight cells, 6 volt supply, battery type "AA", P-15 or mercury type "AA" P-9

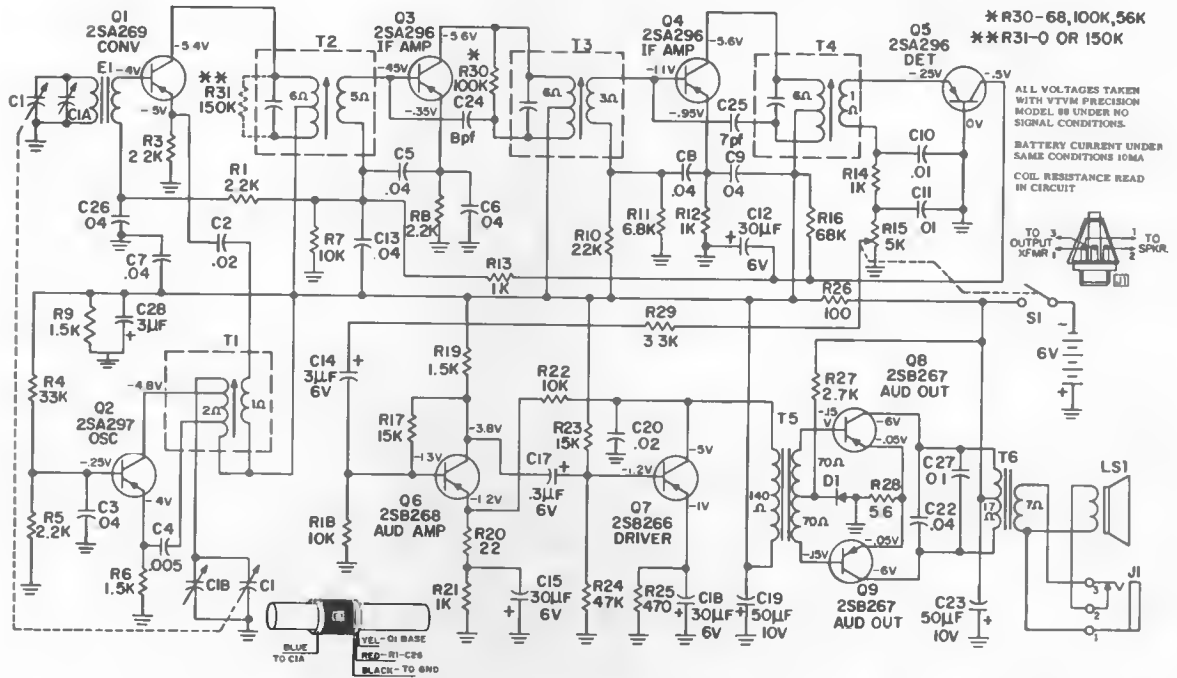

PERMA-CIRCUIT PANEL REMOVAL

1. Remove battery compartment cover (bottom of case) and remove battery holder.
2. Remove two screws located on top of back cover, push out back cover from inside.
3. Remove decorative plate from center of tuning knob (turn counter-clockwise) and unscrew tuning knob spacer. Tuning knob can now be removed.
4. Remove four screws holding perma-circuit panel to cabinet (graph locations D3, B6, K1 and K8) and remove panel.

Speaker will remain in cabinet when panel is removed.

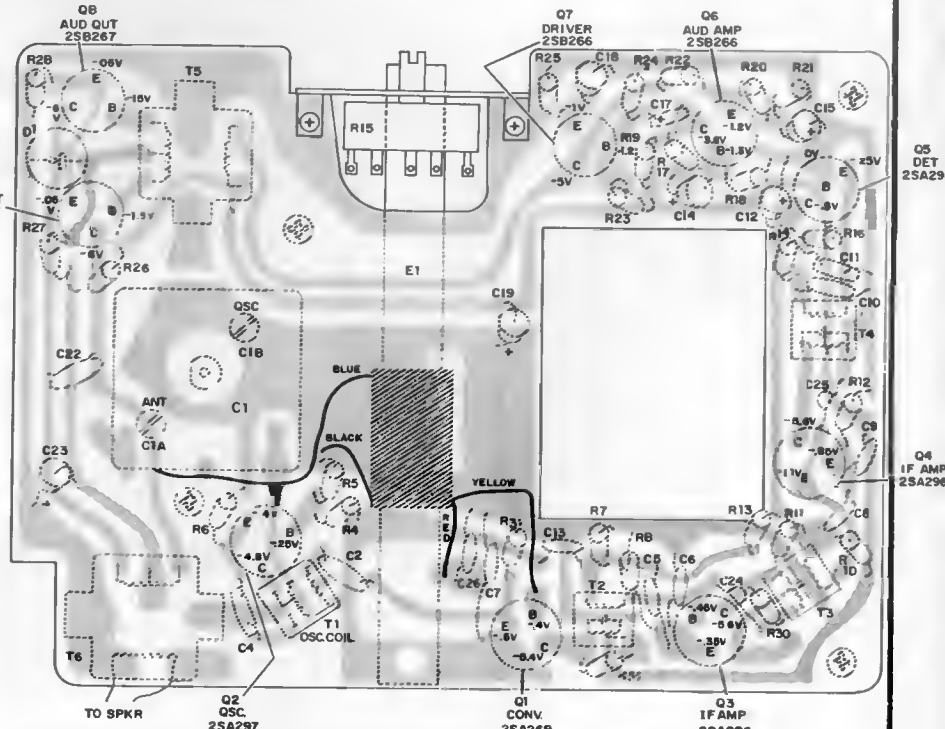

Bottom View of Perma-Circuit Panel Showing Parts Location

PHILCO

TRANSISTOR PORTABLE MODEL T-703 CODE 124

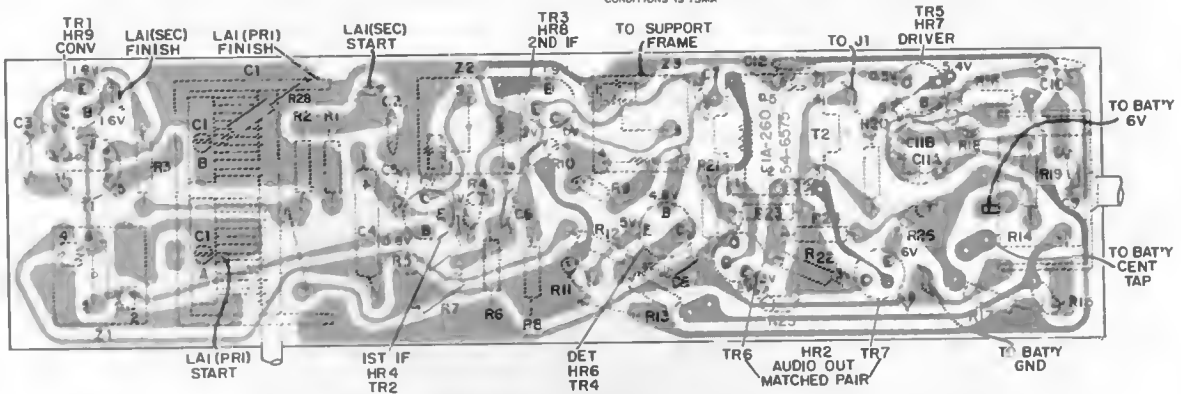
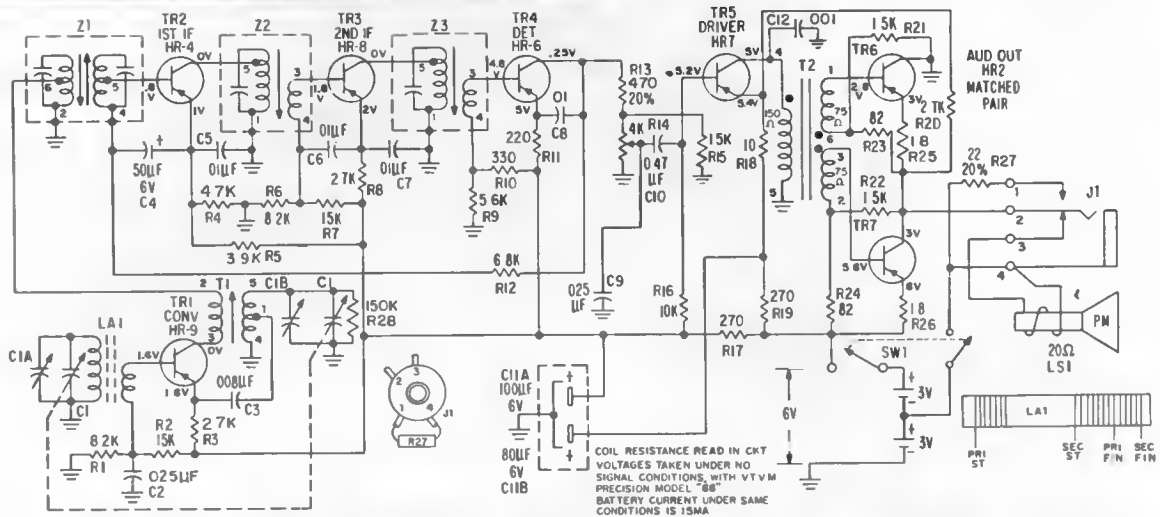

Bottom Composite View of Perma-Circuit Panel

ALIGNMENT PROCEDURE

Allow the test equipment to warm up for fifteen minutes before starting the alignment procedure. Connect the output indicator (a-c voltmeter, or an oscilloscope) across the voice-coil terminals. Use an AM r-f signal generator. Connect the ground lead to chassis, and connect the output lead as indicated in the alignment chart. Attenuate the signal-generator output throughout the alignment so as to maintain the output level below 1 volt.

SIGNAL GENERATOR		RADIO			
STEP	CONNECTION TO RADIO	DIAL SETTING	DIAL SETTING	SPECIAL INSTRUCTIONS	ADJUST
1	Connect signal generator through a .1-uf. condenser to ant. section of gang.	455 kc.	Tuning gang fully open.	Adjust for maximum output in order given.	Z3 - 3rd i-f Z2 - 2nd i-f Z1 - 1st i-f
2	Use radiating loop. (See NOTE 1 below)	600 kc.	600 kc.	Adjust for maximum output. Rock tuning gang while making this adjustment.	T1 - osc. core
3	Same as step 2.	1620 kc.	1620 kc. (Tuning gang fully open)	Adjust for maximum output.	C1B - osc. trimmer
4	Same as step 2.	1400 kc	1400 kc.	Adjust for maximum output.	C1A - antenna trimmer
5	Repeat steps 2, 3 and 4 until no further improvement is obtained. Always "stop on step 4.				

NOTE 1. Use a 6-to-8-turn, 6-inch-diameter loop made up of insulated wire. Connect to generator terminals, and place about one foot from radio loop.

PHILCO

**TABLE/CLOCK AM RADIO
MODELS M-709 & M-869**

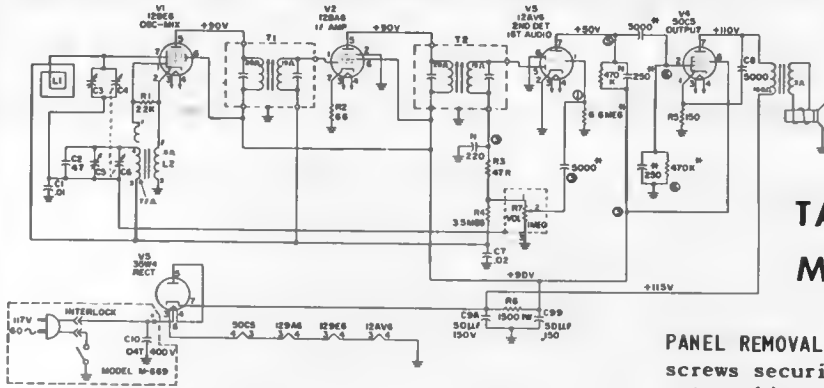

PANEL REMOVAL - To remove panel, unscrew two screws securing cabinet back to front. Separate cabinet back from front by prying away front on line cord side of cabinet. Separate cabinet, being careful not to break time and alarm set knob and antenna leads. Remove knobs and nut on volume control. Remove two screws located at E3 and D10 (see parts location). Unsolder speaker, antenna and clock wires (M-709 only). Panel may now be removed.

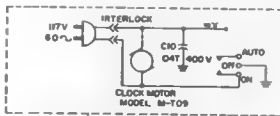

NOTE
ALL COMPONENTS MARKED WITH AN ASTERISK ARE CONTAINED IN ONE UNIT. CONNECTIONS ARE ENCIRCLED NUMBERS
ALL VOLTAGES AND RESISTANCES TAKEN WITH "PRECISION" VTVM MODEL "8F" VOLUME CONTROL SET AT MINIMUM, NO SIGNAL IN
RESISTANCES TAKEN WITH COILS AND TRANSFORMERS IN CIRCUIT

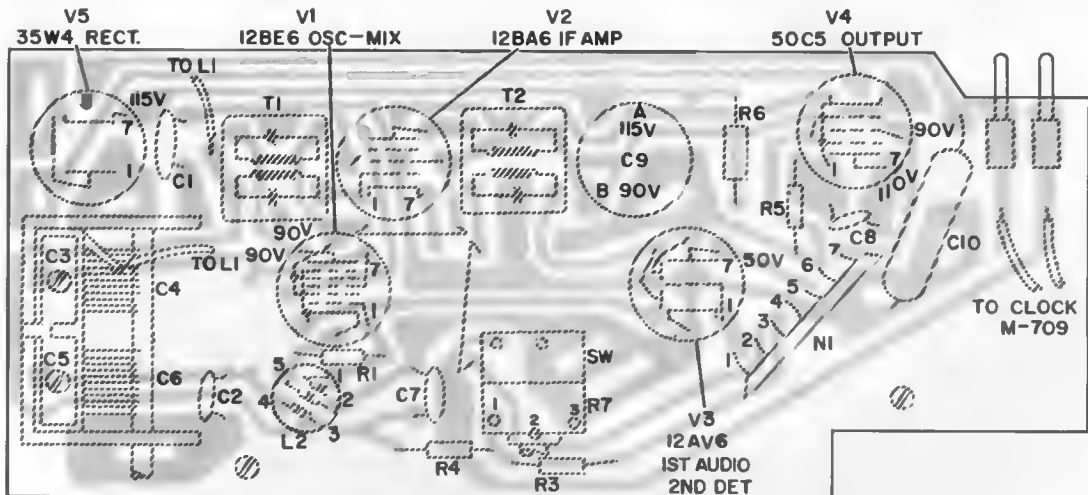

Component Location, Foil Side of Perma-Circuit Panel

ALIGNMENT - To eliminate shock hazard, use an isolation transformer between radio chassis and a-c power outlet. Allow radio and test equipment about 15 minutes to warm up before starting alignment. Connect an a-c VTVM across the speaker voice coil. Use an AM R-F signal generator connected as indicated in chart. Set volume control to maximum no signal output. Keep generator output as low as possible.

ALIGNMENT CHART

SIGNAL GENERATOR		RADIO			
STEP	CONNECTION TO RADIO	DIAL SETTING	DIAL SETTING	SPECIAL INSTRUCTIONS	ADJUST
1	R-F section of gang through a .1mf cap.	455KC	Gang fully open	Adjust for max. output in order given.	T1-bot. & top T2-bot. & top
2	Use radiated signal (See note)	600KC	600KC	Adjust for max. output; rock tuning gang while making adjustment.	L1-osc.
3	Use radiated signal	1650KC	Gang fully open	Adjust for max. output.	C5-osc. trim.
4	Use radiated signal	1500KC	1500KC	Adjust for max. output.	C3-ant. trim.
5	Repeat steps 2, 3 and 4 until no further improvement is obtained.				

NOTE: Use a 6 to 8 turn, 6-inch diameter loop made up of insulated wire. Connect to generator terminals, and place about one foot from radio loop.

VOLUME R-24, MOST-OFTEN-NEEDED 1964 RADIO SERVICING INFORMATION

PHILCO Models M-712, M-714, M-715, M-716, M-871, M-872, M-874, M-876

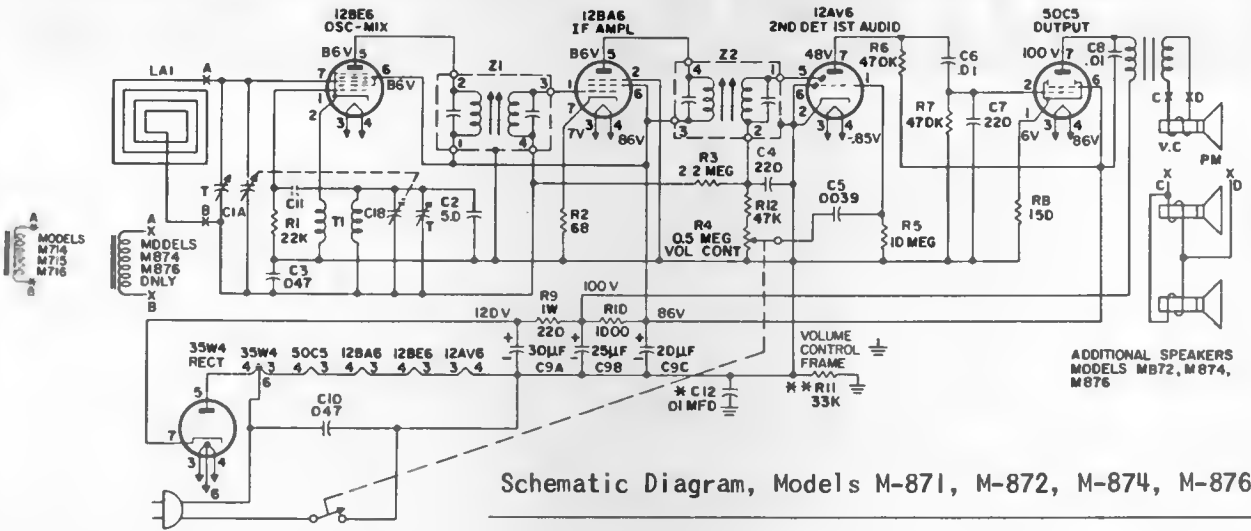

Schematic Diagram, Models M-871, M-872, M-874, M-876

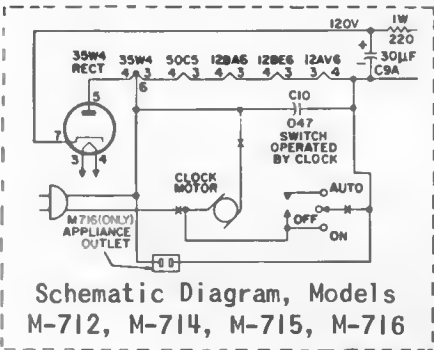

Schematic Diagram, Models M-712, M-714, M-715, M-716

I.F. 455 KC.

C11 IS PART OF OSC. COIL
 * MODEL M876, M716.
 ** MODELS M871, M872, M874, M712, M714, M715.

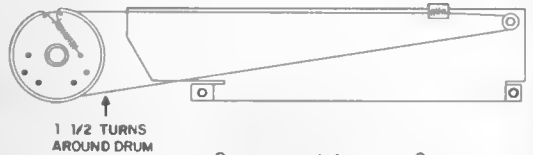

Dial Cord Stringing Models M-714, M-715, M-874

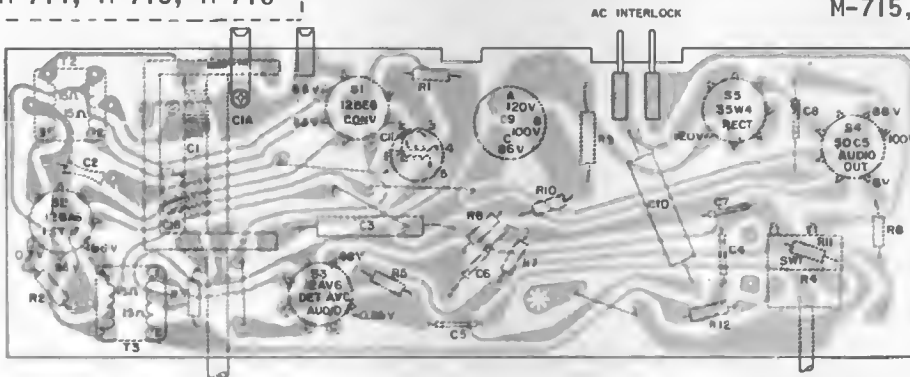

Perma-Circuit Panel, AM Models M-712, M-871, M-872, Bottom View

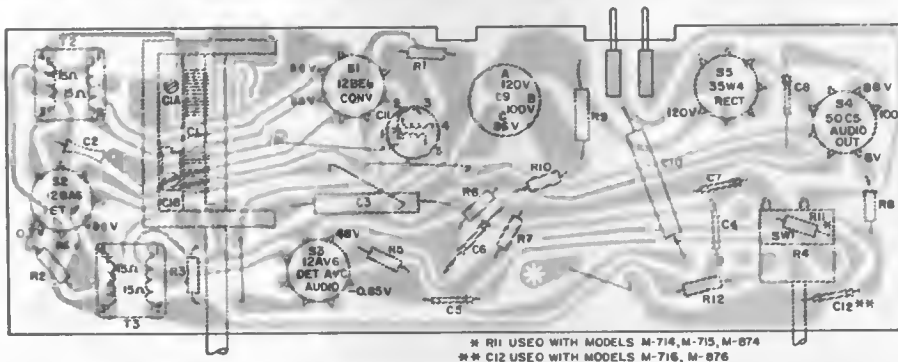

Perma-Circuit Panel, AM Models M-714, M-715, M-716, M-874, M-876, Bottom View

PHILCO

TABLE/CLOCK AM-FM RADIOS M-719, M-798, M-936, M-937, M-938, M-939

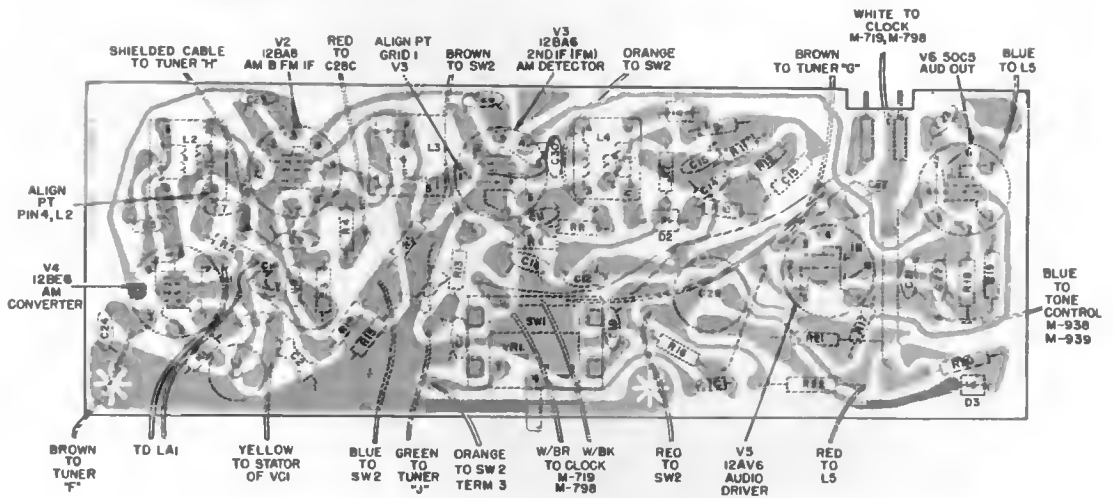
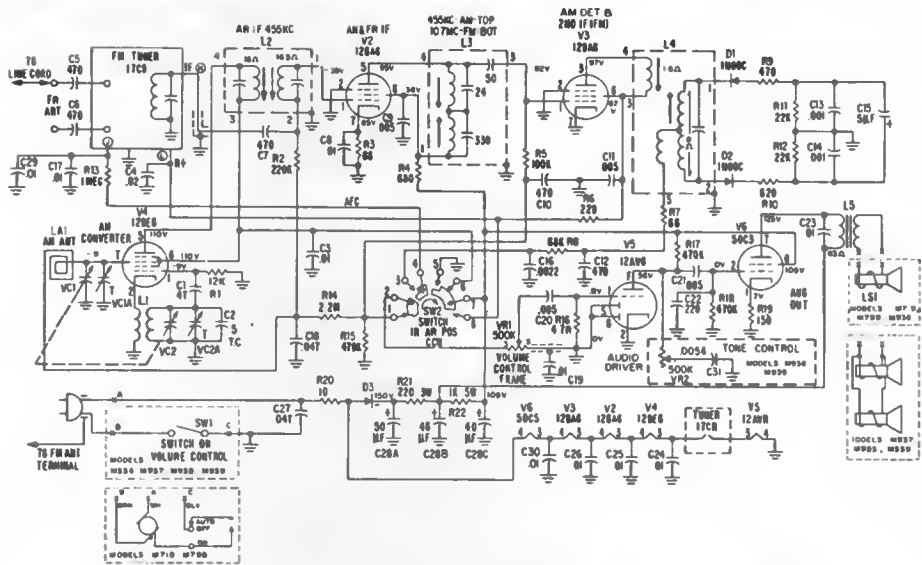

Perma-Circuit Panel, AM-FM Models, Bottom View

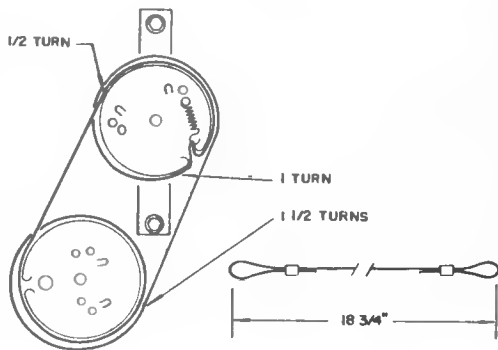

Tuner Dial Cord Stringing
FM Models

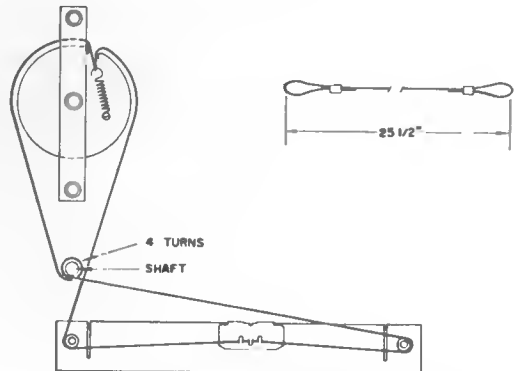

Main Dial Cord Stringing
FM Models

PHILCO

TRANSISTOR PORTABLE MODEL T-902, CODE 128

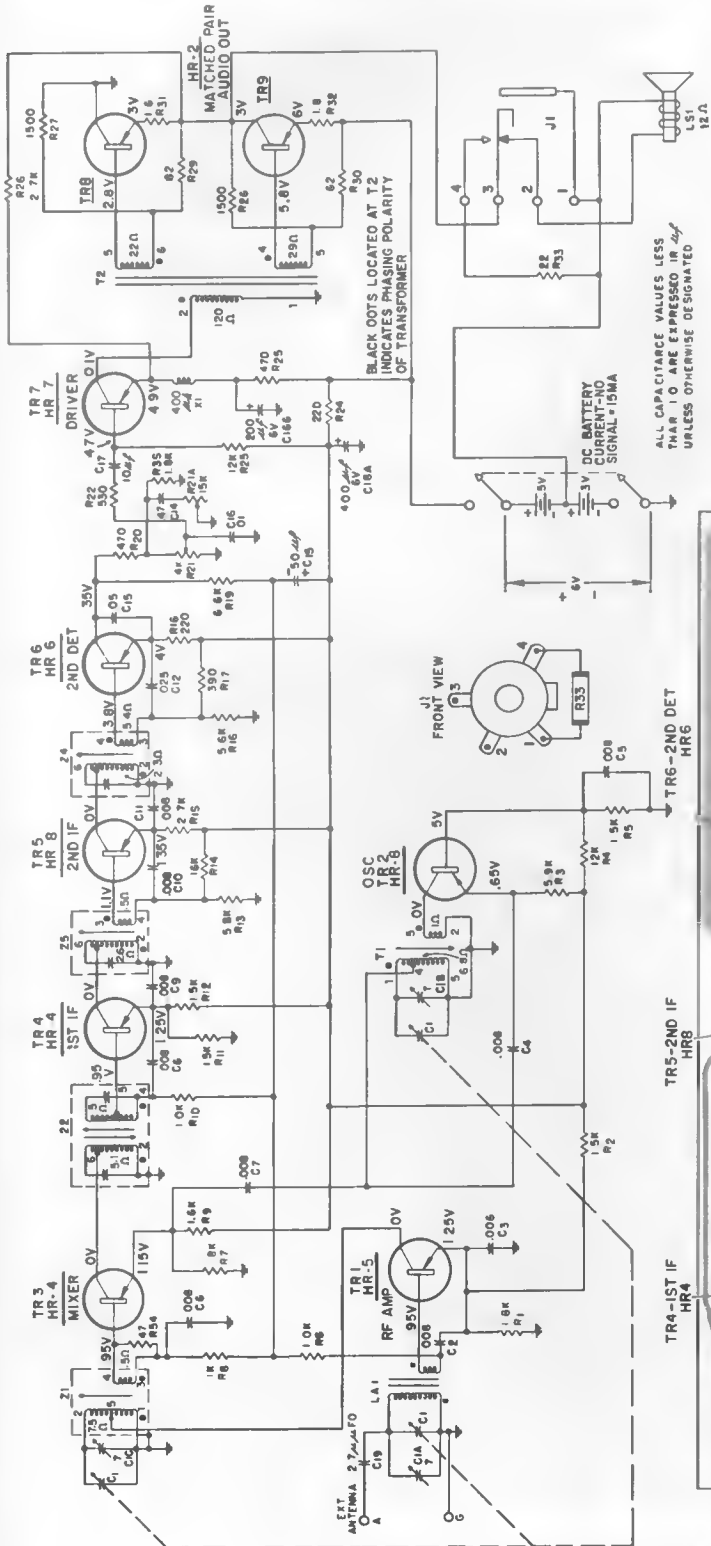

FREQUENCY COVERAGE: 540 to 1620 KC.
INTERMEDIATE FREQUENCY: 455 KC.

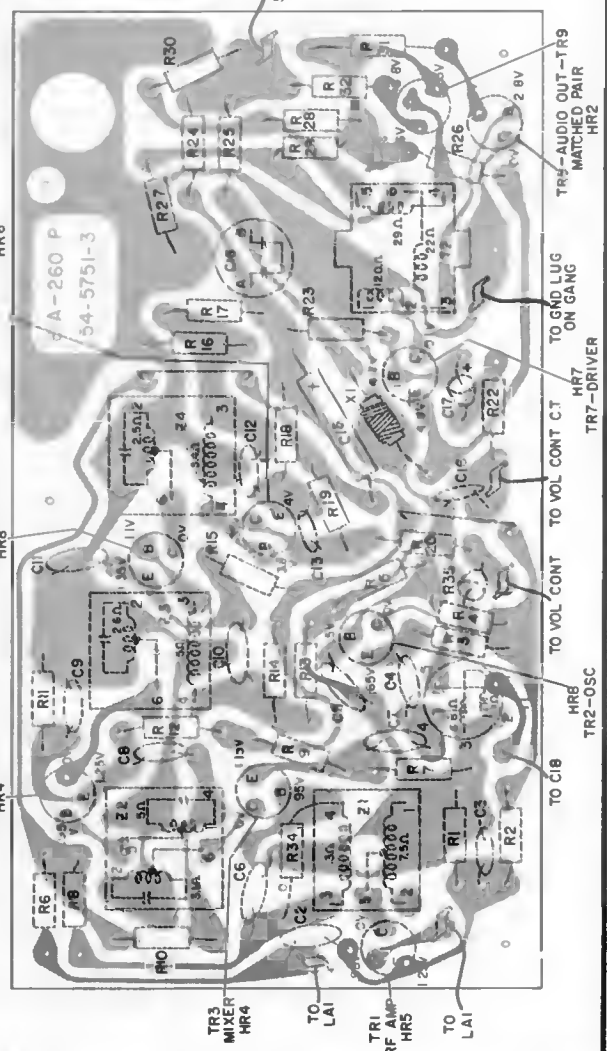
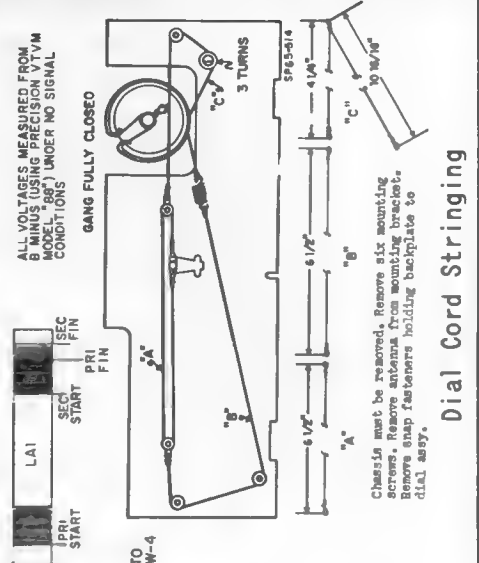

Base Layout - Bottom View of Perma-Circuit Panel

PHILCO

AM-FM TRANSISTOR PORTABLE MODEL T-907

(Material below and the next two pages)

REMOVAL OF FM TUNER PANEL

1. Remove chassis from cabinet. See "Chassis Disassembly" instructions.
2. Remove 2 magnecore antenna mounting clamps and swing magnecore out of the way.
3. Loosen 2 FM tuner shield screws and remove shield.
4. Disconnect FM tuner leads from their points of origin. See FM tuner perma-circuit illustration. Do Not attempt to disconnect leads from the tuner panel. Bring free leads up through hole in main perma-circuit panel.
5. Unsolder "Tuning Gang Grounds" (See FM tuner perma-circuit illustration), separate and straighten lugs. Be sure lugs are free of excess solder.
6. Unsolder "Shield Grounds" from rear or outside of back shield. Be sure lugs are clean and free in the shield holes.
7. While alternately heating the gang terminals C1-R-F and C1-osc., gently pry panel out using a thin bladed tool.

CHASSIS DISASSEMBLY

1. Remove back by loosening back retaining screw. **CAUTION** - Monopole antenna lead is connected; disconnect lead from antenna.
2. Remove knobs.
3. Remove nut holding band switch clamp and remove clamp.
4. Remove back mounting threaded post.
5. Remove nut at volume control end of back plate.
6. Remove nut at left end of FM R-F sub-assembly.

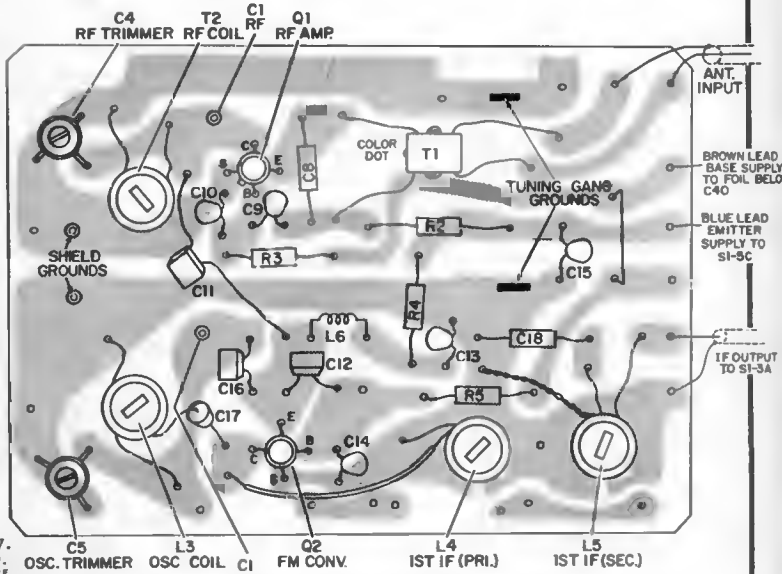

Top Composite View of FM Tuner Perma-Circuit Panel

7. Remove nut in front of 1st I-F, T3.
8. Remove panel, dial, switch and mtg. plate assembly.

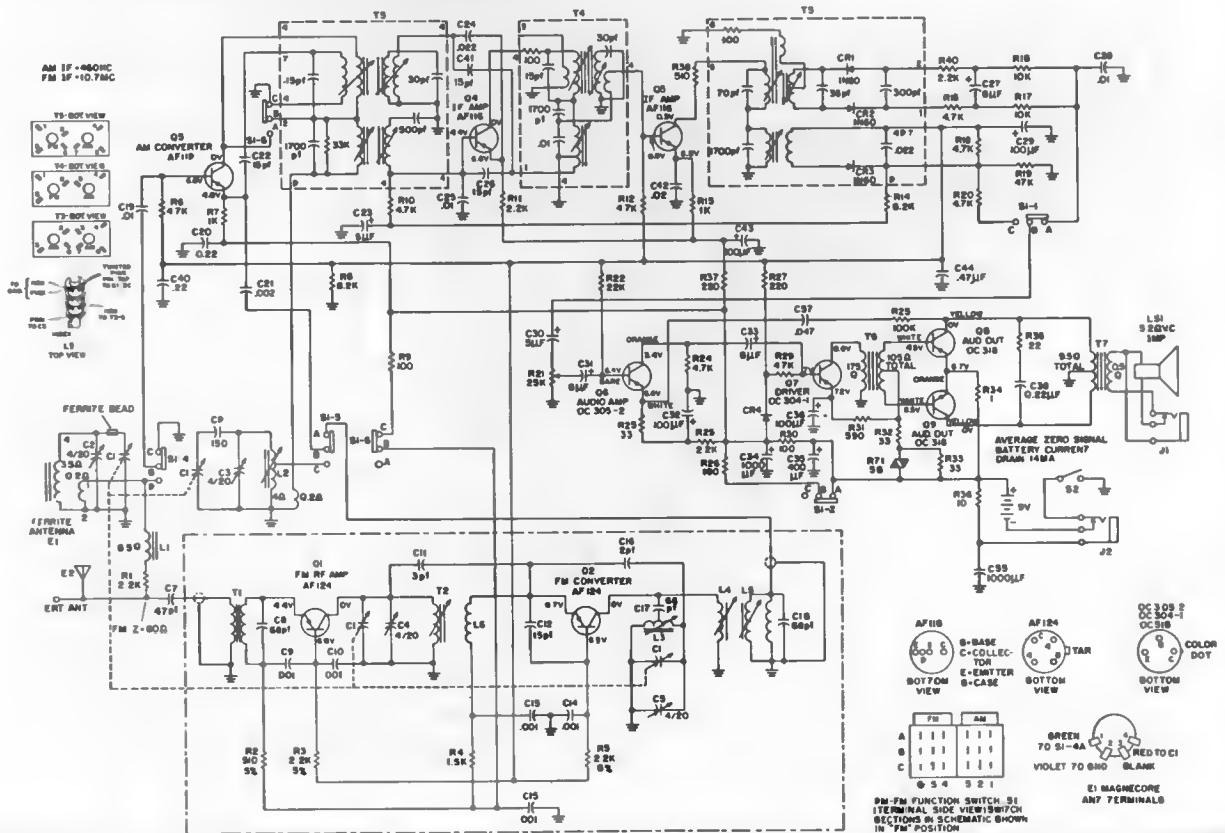

VOLUME R-24, MOST-OFTEN-NEEDED 1964 RADIO SERVICING INFORMATION

PHILCO Model T-907, Continued from preceding page, alignment on next page

BATTERY SUPPLY - 6 type "C" cells (number 635) in a 9 volt supply. Provision for connecting an external battery or AC power supply. Special receptacle automatically disconnects internal battery.

CIRCUIT - Nine transistor, 3 diode, AM-FM super-heterodyne.
FREQUENCY COVERAGE - AM, 540KC to 1610KC
 FM, 87.5MC to 108.5MC
INTERMEDIATE FREQUENCY - AM, 460KC
 FM, 10.7MC

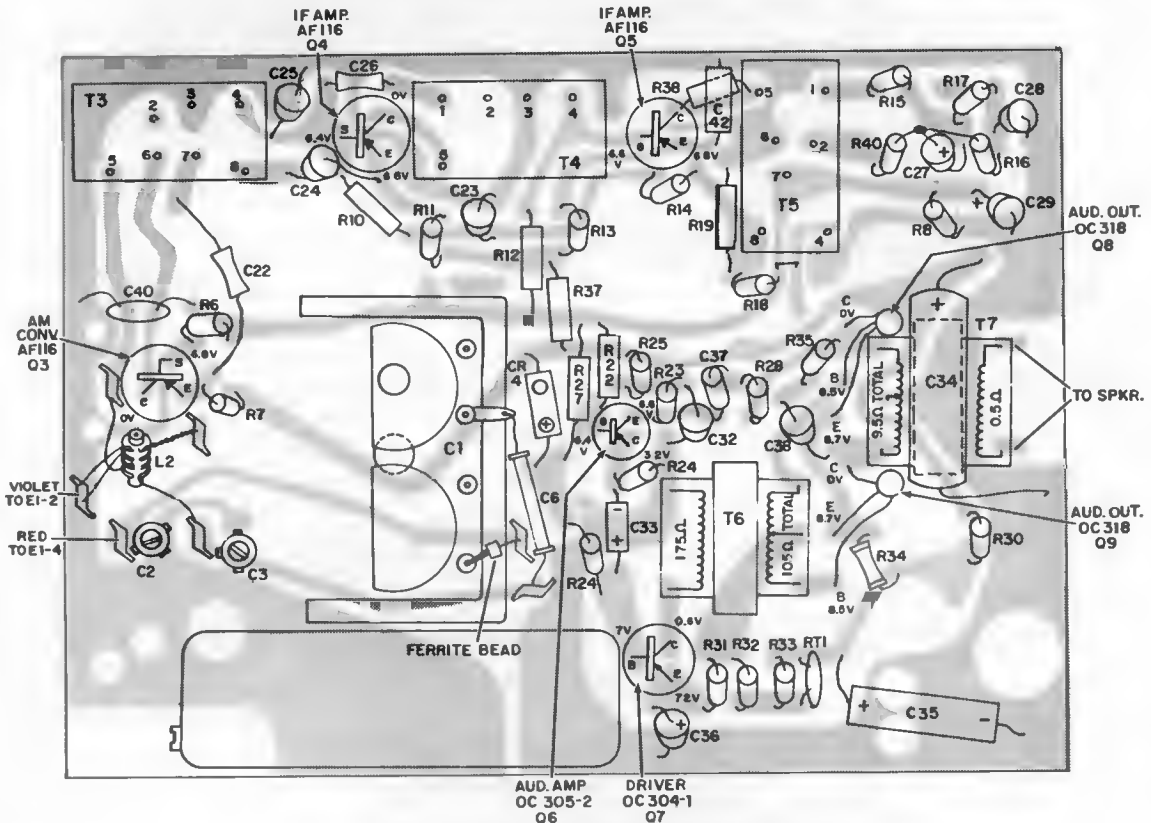

Bottom Composite View of Main Perna-circuit Panel

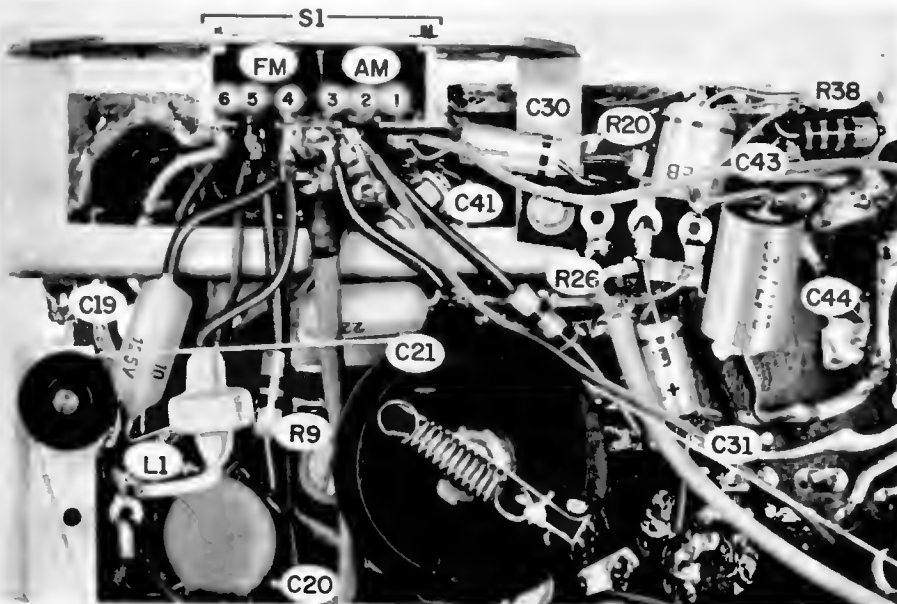

Under Panel Component Identification

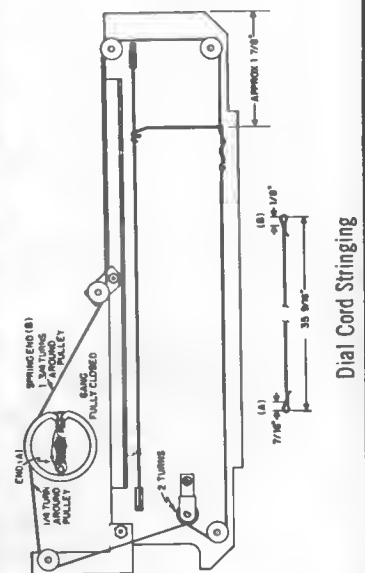

VOLUME R-24, MOST-OFTEN-NEEDED 1964 RADIO SERVICING INFORMATION

PHILCO Model T-907, Alignment Information, Continued from preceding pages

AM ALIGNMENT PROCEDURE

Allow generator to warm up for 15 minutes.
 Check pointer-scale alignment.
 Chassis must be removed from cabinet. See disassembly instructions.
 Connect scope or AC meter across speaker voice coil to observe output.
 Volume control to maximum.
 Check battery supply voltage, 9 volts.

FM ALIGNMENT PROCEDURE

Check pointer-scale alignment.
 Chassis must be removed from cabinet. See disassembly instructions.
 Depress FM push button.
 Connect scope across volume control to observe "S" curve (see illustration below).
 Loosely couple generator output to telescope antenna. Use only sufficient signal for clean scope presentation --- Do Not Overload.

AM ALIGNMENT CHART

Signal Generator			Radio		
Step	Connection To Radio	Frequency	Dial Setting	Special Instructions	Adjust
1	To base of AM converter, Q3, thru a .01 μ fd capacitor.	460KC	1500KC	Adjust, in order given, for maximum output.	T3, 1st AM I-F top & bot. T4, 2nd AM I-F, top T5, 3rd AM I-F, top
2	Use radiating loop.	600KC	600KC	Adjust for maximum output.	L2, AM oac. core
3	Radiating loop	1500KC	1500KC	Adjust for maximum output.	C3, AM osc. trimmer
4.	Repeat Steps 2 and 3 until no further improvement is obtained.				
5	Radiating loop	600KC	600KC	Adjust for maximum output by sliding ant. coil on core.	E1, AM magnecore ant.
6	Radiating loop	1500KC	1500KC	Adjust for maximum output.	C2, AM ant. trimmer
7	Repeat Steps 5 and 6 until no further improvement is obtained.				

NOTE: For radiating loop, use a 6 to 8 turn, 6-inch diameter loop made up of insulated wire. Connect to generator terminals and place about one foot from antenna coil.

FM ALIGNMENT CHART

Sweep Generator			Radio		
Step	Center Frequency	Sweep Width	Dial Setting	Special Instructions	Adjust
1	10.7MC	50KC		Adjust for cross-over at 10.7MC.	T5 - FM top.
				Adjust in order given for maximum output and best symmetry. Repeat	T5 - FM bottom T4 - FM Top & Bot. T3 - FM Top & Bot. L4 & L5
2	89MC	25KC	89MC	Adjust for maximum output.	L3 - FM osc. core T2 - FM R-F core
3	102MC	25KC	102MC	Adjust for maximum output.	C5 - FM osc. trim. C4 - FM R-F trim.
4	Repeat Steps 2 and 3 until no further improvement is noted.				

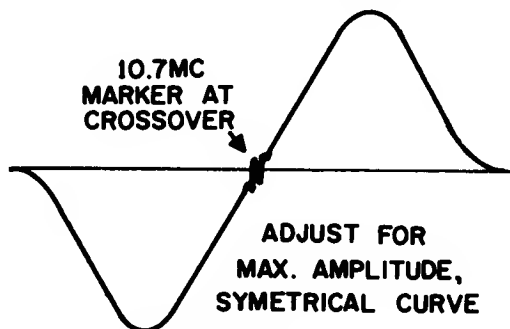

FM Alignment Curve

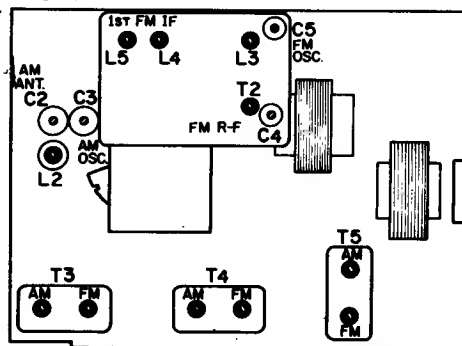

Chassis Alignment Points

PHILCO Model M-1428 and Model M-1430

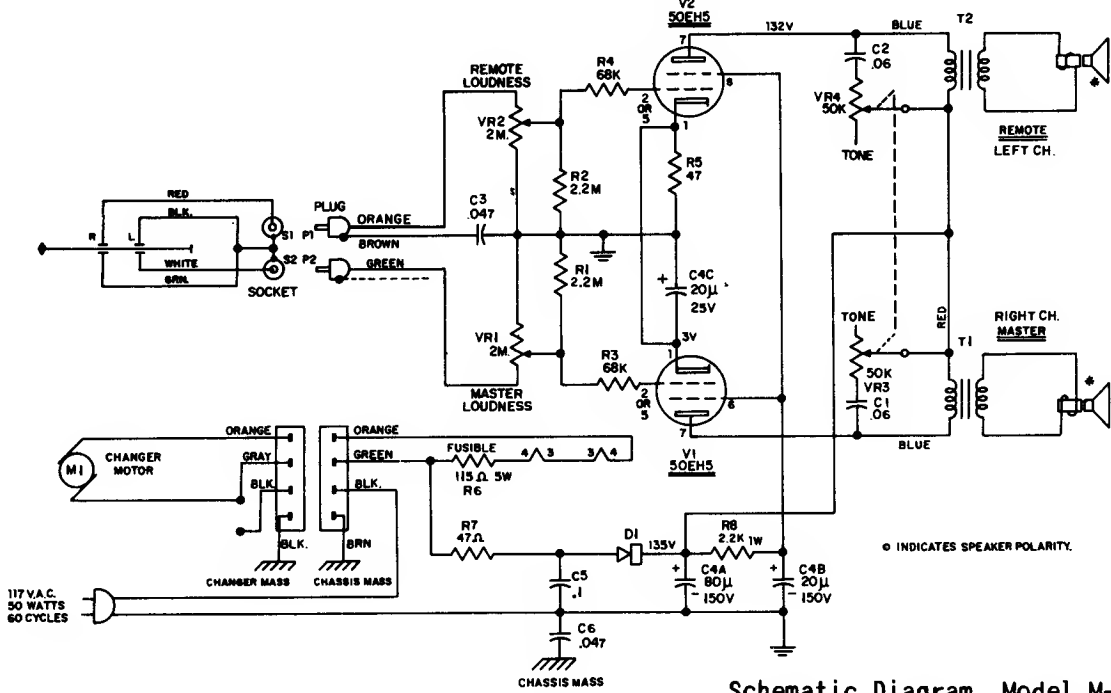

Schematic Diagram, Model M-1428

AMPLIFIER REMOVAL - MODEL M-1428

1. Remove four Phillips screws securing right speaker panel and remove panel.
2. Remove knobs and T-nuts from controls.
3. Remove nut on stud securing rear of chassis.
4. Remove four Phillips screws securing changer.

5. Lift changer and remove phono power and phono input cables.
6. Push cables through holes in back of changer compartment.
7. Pull enough left hand speaker cable into changer compartment in order to remove amp.
8. Amp. may now be removed by lifting rear of chassis up and out.

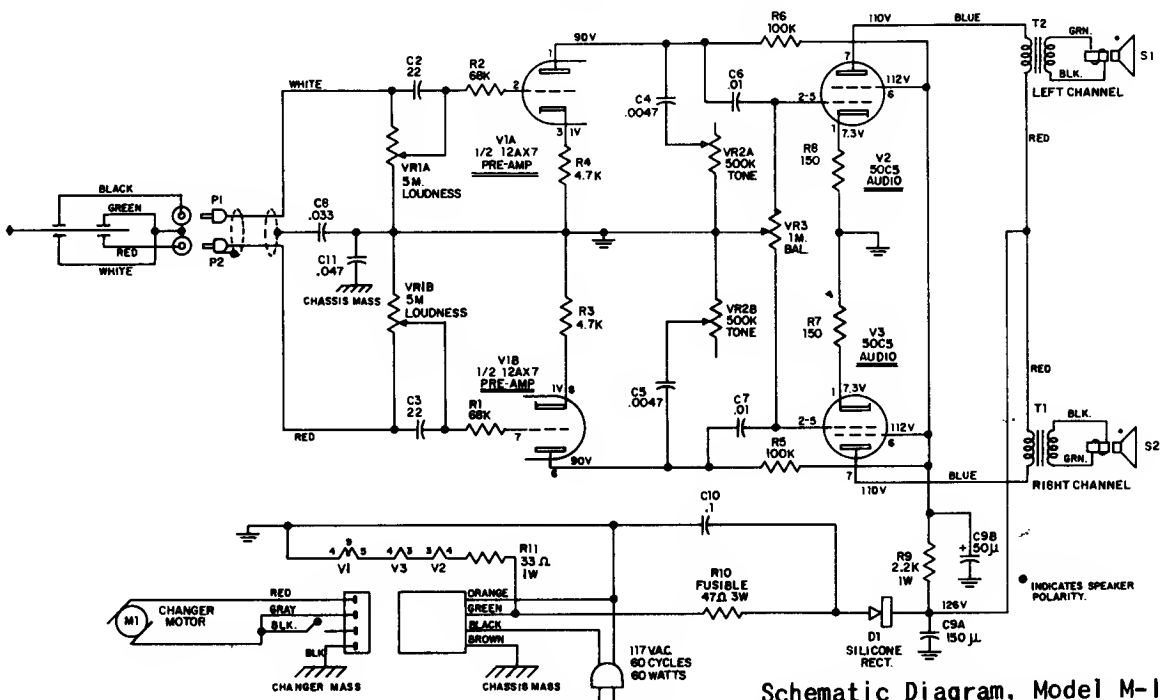

Schematic Diagram, Model M-1430

PHILCO

TRANSISTOR PORTABLE AM-FM MULTI-BAND T-911

(Service material continued on the next page, at right)

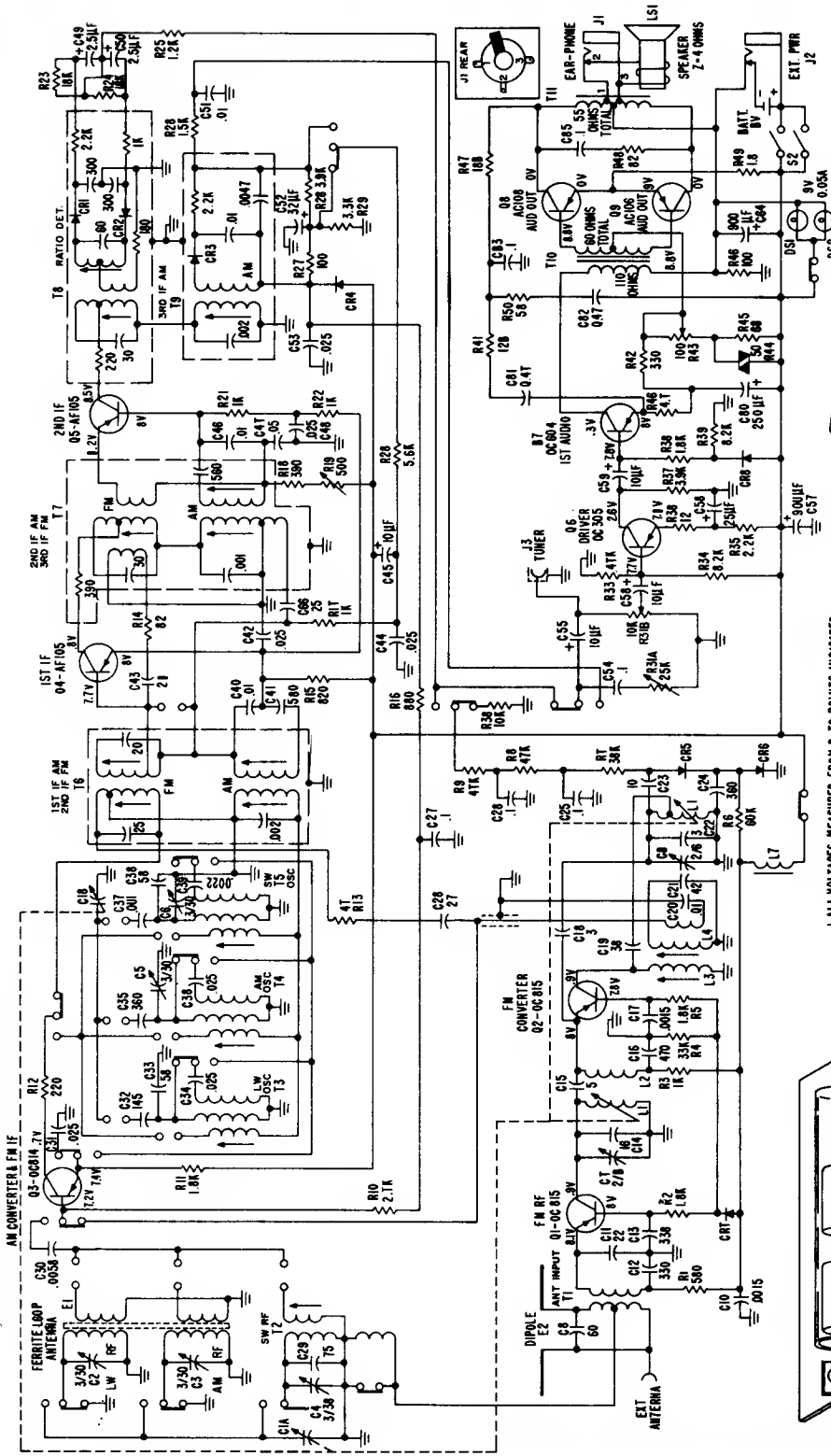

1. ALL VOLTAGES MEASURED FROM B-TO POINTS INDICATED.
2. VOLTAGES TAKEN UNDER 80 SIGNAL CONDITIONS WITH VTM IN PRECISION MODEL "B" EXCEPT Q1, Q2 & Q3
3. VOLTAGES READ ON Q3 TAKEN IN "AM POSITION"
4. VOLTAGES READ ON Q1, Q2 TAKEN IN "FM POSITION"

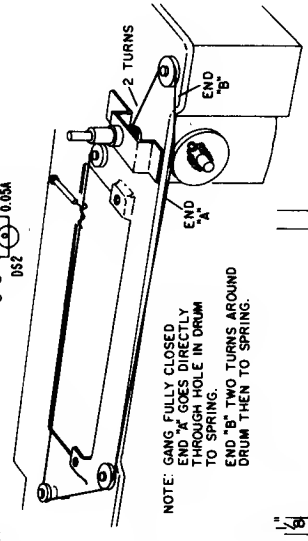

NOTE: GANG FULLY CLOSED
END "A" GOES DIRECTLY
THROUGH HOLE IN DRUM
TO SPRING.
END "B" TWO TURNS AROUND
DRUM THEN TO SPRING.

Dial Cord Stringing

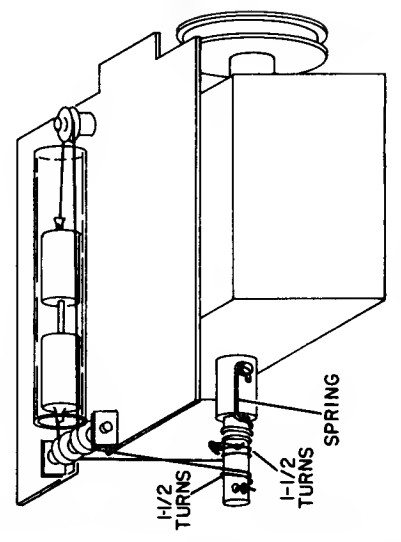
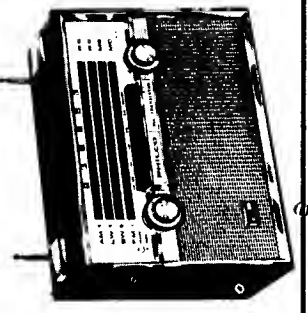

FM Tuner Dial Cord

VOLUME R-24, MOST-OFTEN-NEEDED 1964 RADIO SERVICING INFORMATION

PHILCO Model T-911 Service Data, Continued from preceding page

Bottom View - IF Strip

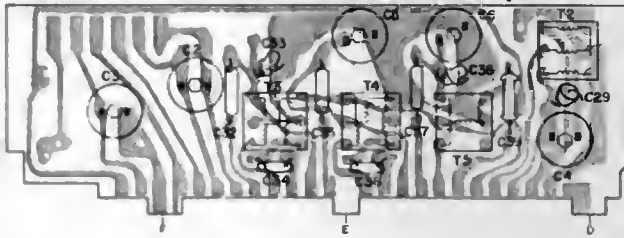

Top View - Coil Plate

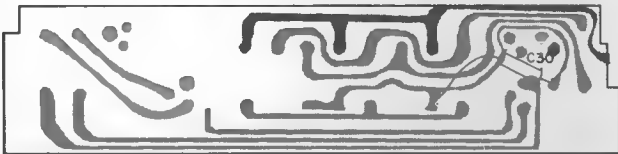

Top View - Pushbutton Assy. Bottom

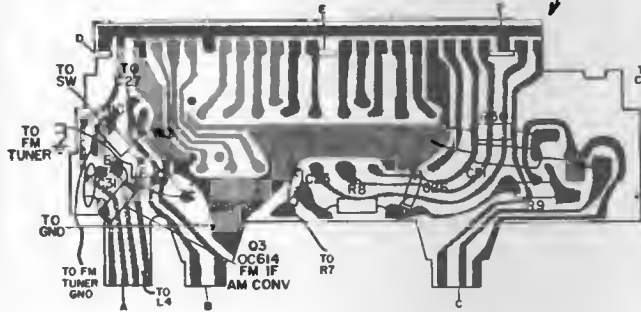

Top View - Pushbutton Assy. Top

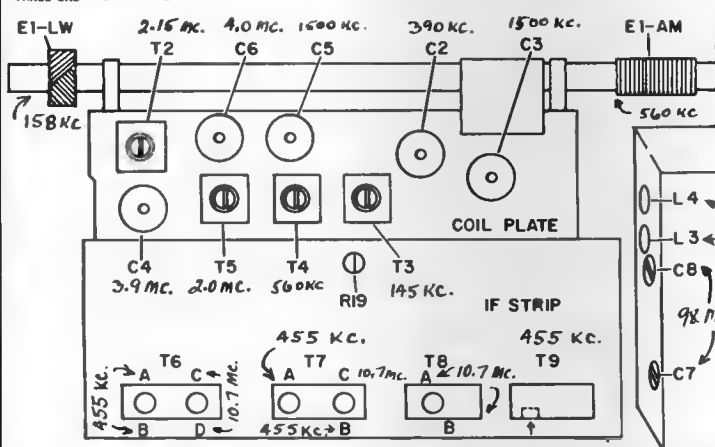
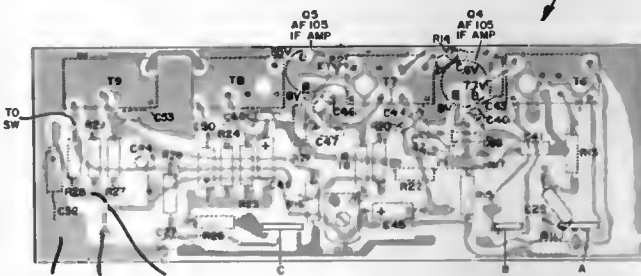

Alignment Points for AM, FM, LW & SW

FM TUNER

Q2 OC615 FM CONV

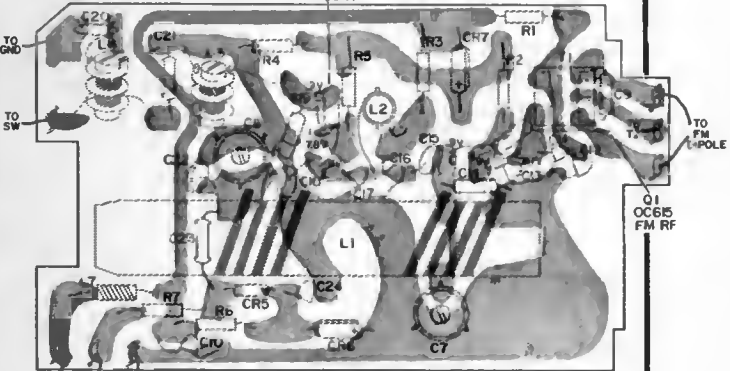

Bottom View FM Tuner Panel

Q7 OC 604 DRIVER

Q9 AC 106 AUDIO OUT

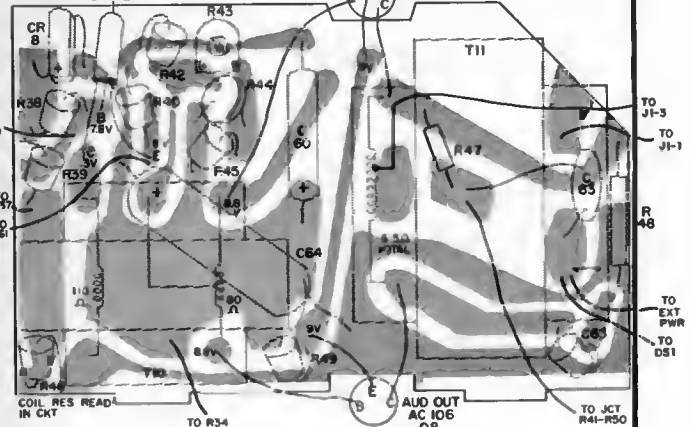

Bottom View Audio Output Stage

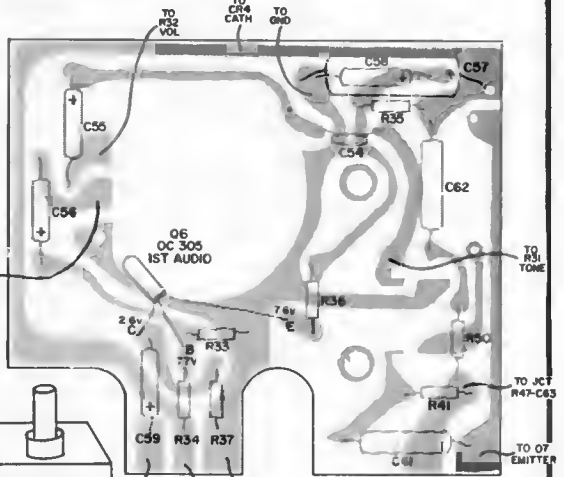

Bottom View Audio Driver Stage

PHILCO
Model M-1421
and
Model M-1529

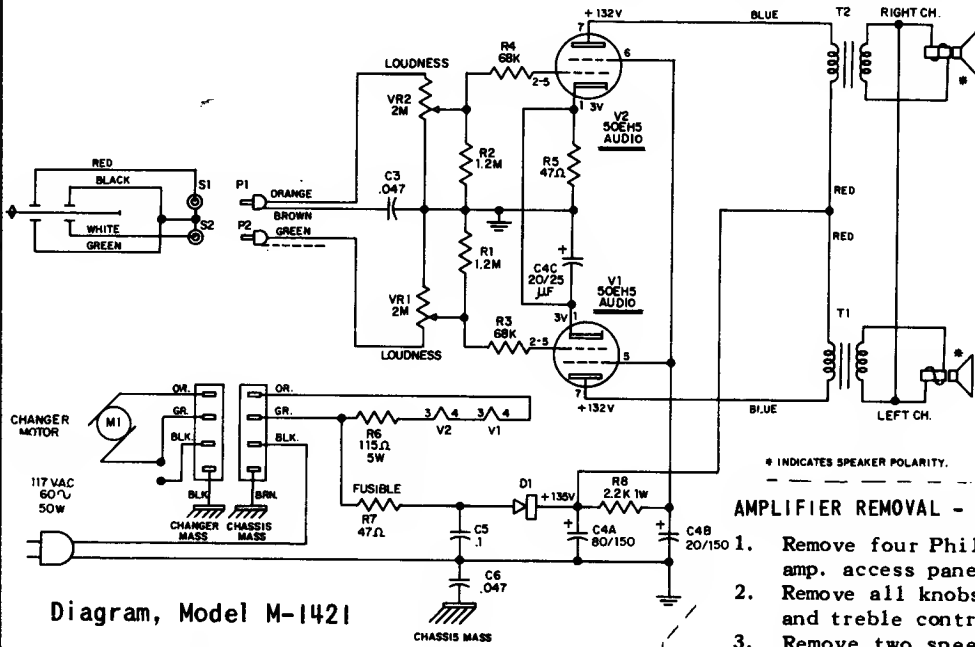

Diagram, Model M-1421

AMPLIFIER REMOVAL - MODEL M-1421

1. Remove six Phillips screws securing changer mounting board to cabinet.
2. Remove changer mounting board and amp. assembly.
3. Remove two T-nuts securing amp. to changer mounting board.
4. Amp. may now be removed.

AMPLIFIER REMOVAL - MODEL M-1529

1. Remove four Phillips screws securing rear amp. access panel and remove panel.
2. Remove all knobs and two T-nuts from bass and treble controls.
3. Remove two speed nuts on studs securing rear of chassis.
4. Straighten clip securing left side of changer. Lift left side of changer to free mounting screws. Slide changer to left in order to free right mounting screw.
5. Lift changer and remove phono power and phono input cables.
6. Remove two cable clamps securing phono power and phono input cables.
7. Remove amp. while feeding cables through slot in side of changer drawer.

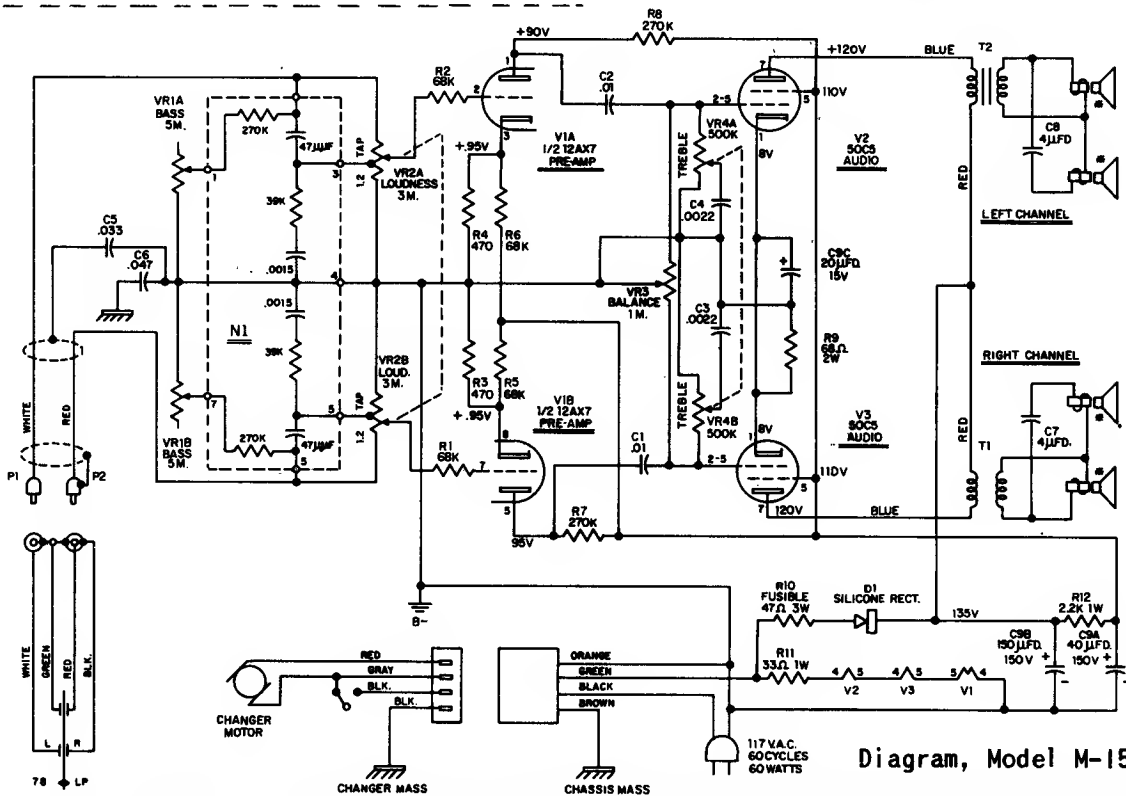

Diagram, Model M-1529

PHILCO Model M-1537 and Model M-1416 (Below)

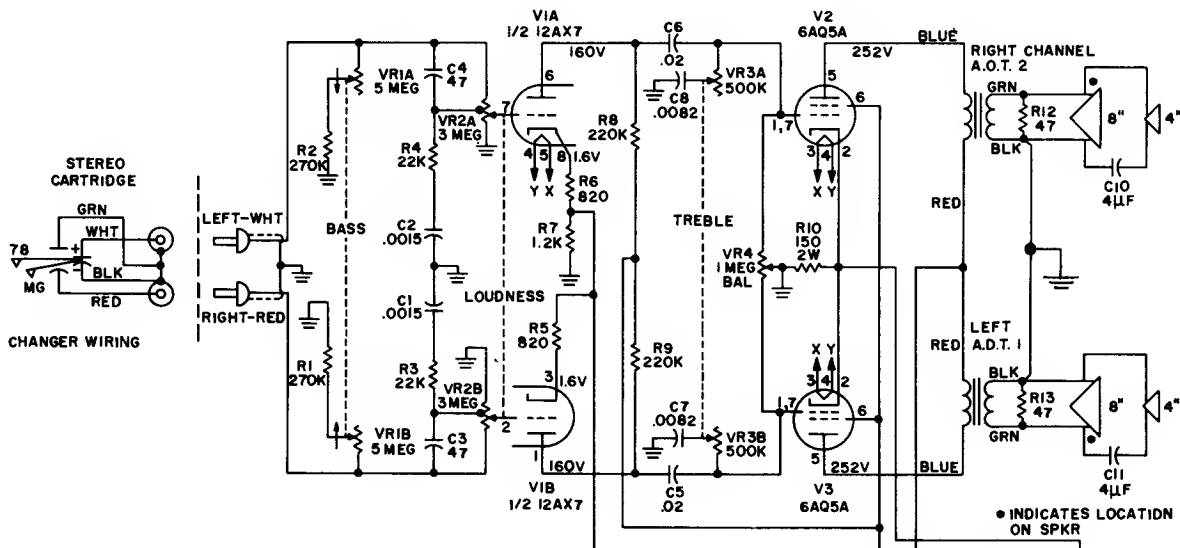

Schematic Diagram, Model M-1537

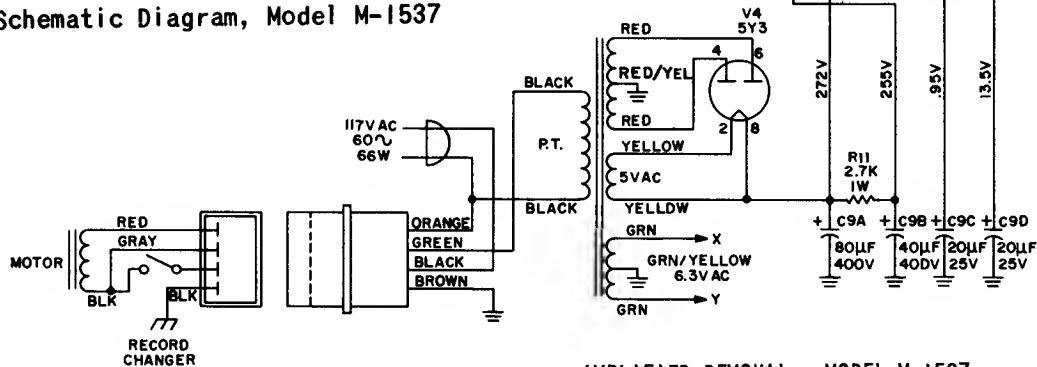

AMPLIFIER REMOVAL - MODEL M-1537

1. Remove two Phillips screws from back of cabinet. Do not remove two screws that fasten grille to cabinet back.
2. Remove plug on right side of changer base. Grasp washer on changer, hold down screw with long nose pliers. Grasp washer on side opposite washer opening through hole in right side of changer bin.
3. Lift right side of changer and slide changer to the right in order to free left side.
4. Unplug phono power and phono input cables. Set changer aside.
5. With a short screw driver, remove the two Phillips screws holding the amplifier compartment in the cabinet. These screws are located at the top of the changer compartment and run through the changer bin stop blocks.
6. Loosen phono power and phono input cable hold downs.
7. Slide amplifier compartment out of cabinet guiding all cables through openings in side and back of cabinet.
8. Remove knobs and T-nuts located on controls behind knobs.
9. Remove two speed nuts from studs on amplifier rear flange. Lift amplifier to clear studs and pull away from compartment.

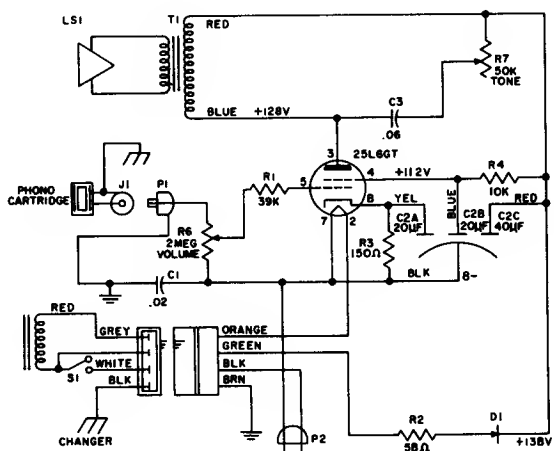

Schematic Diagram, Model M-1416

PHILCO

MODELS L-1651, L-1652, & L-1653

(Service material continued on pages 125 through 128)

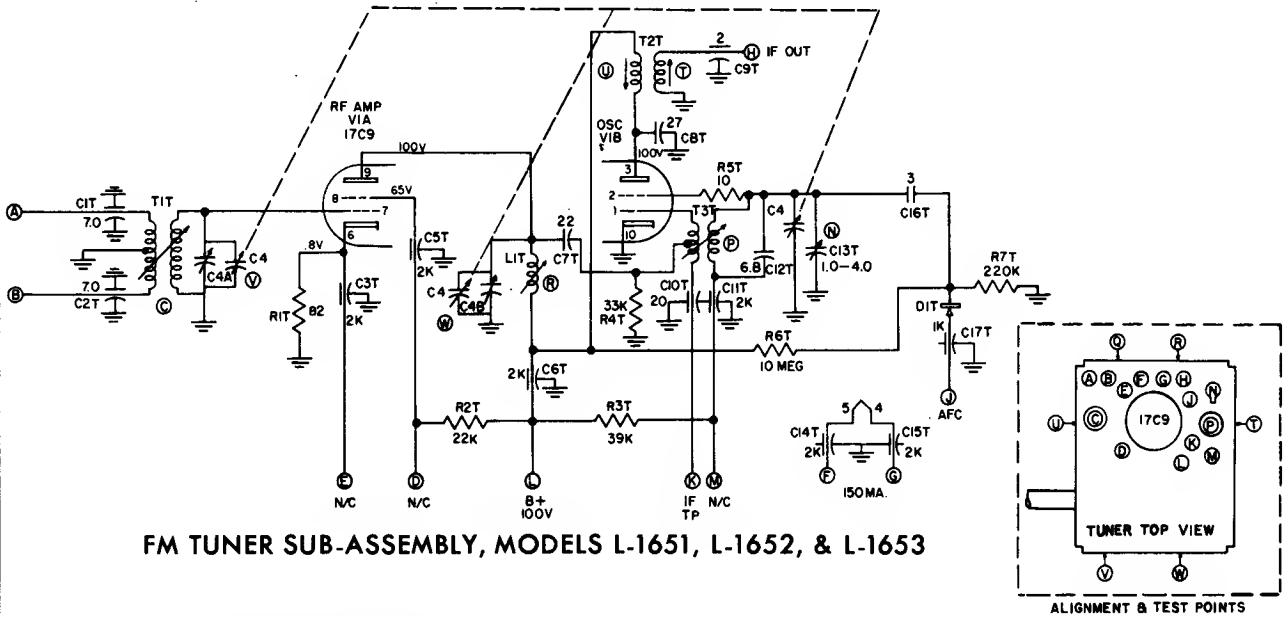

FM TUNER SUB-ASSEMBLY, MODELS L-1651, L-1652, & L-1653

FM TUNER SUB-ASSY. REMOVAL -
MODELS L-1651, L-1652 & L-1653

1. Remove 8 screws holding front faceplate to chassis.
2. Remove faceplate and large pulley connected to AM tuning gang. DO NOT REMOVE dial cord.
3. Remove connecting cord from FM and AM tuning gang pulleys only.
4. Unsolder 6 wires that connect tuner to chassis.
5. Remove 4 sheet metal screws holding front and back of tuner in chassis.
6. Remove tuner by forcing from chassis.

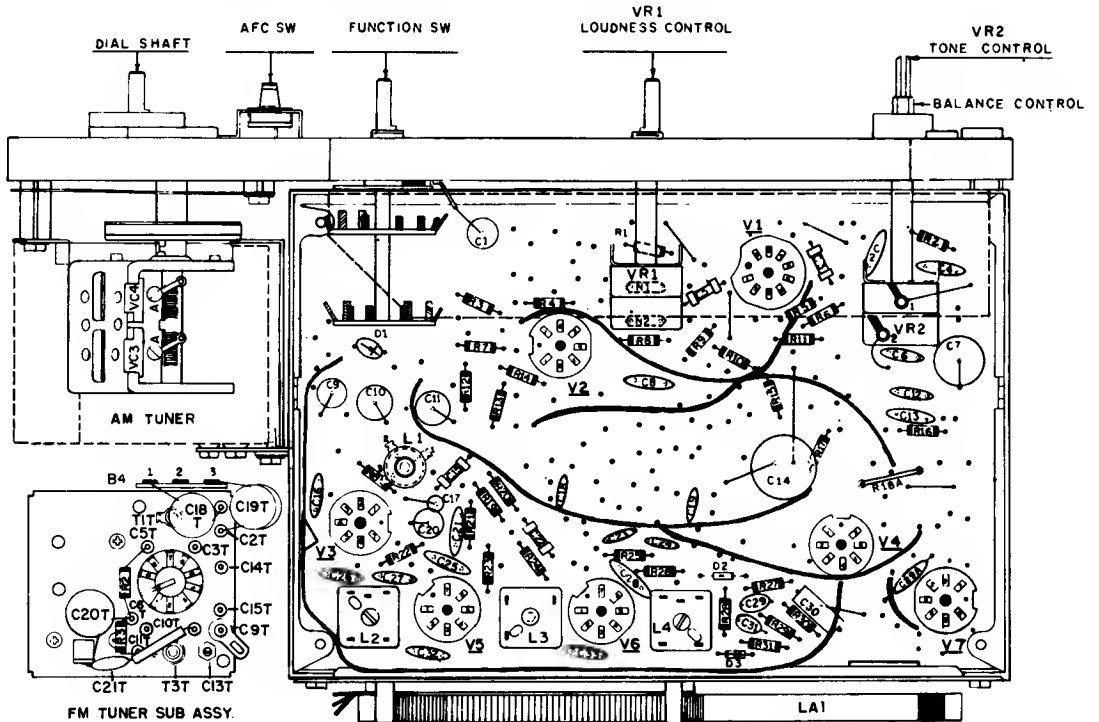

Top View Component Location Model L-1651

PHILCO

MODEL L-1651
AMPLIFIER AND TUNER

(Continued from page 124,
Diagram is on page 125)

AMPLIFIER AND TUNER PANEL REMOVAL -
L-1651, L-1652 & L-1653

1. Unsolder all wires holding perma-circuit panel in chassis.
2. Remove 6 sheet metal screws that secure perma-circuit panel to front panel and FM tuner.
3. Remove 2 nuts from function switch and loudness control.
4. Pull panel and associated chassis from front panel.
5. Remove 5 sheet metal screws holding perma-circuit panel to chassis.
6. Lift panel away from chassis.

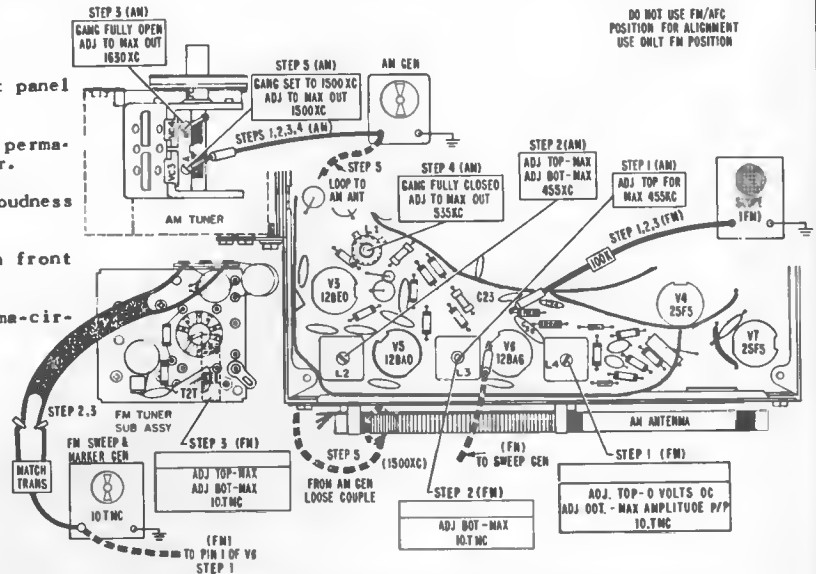

Alignment Procedure Chart, Model L-1651

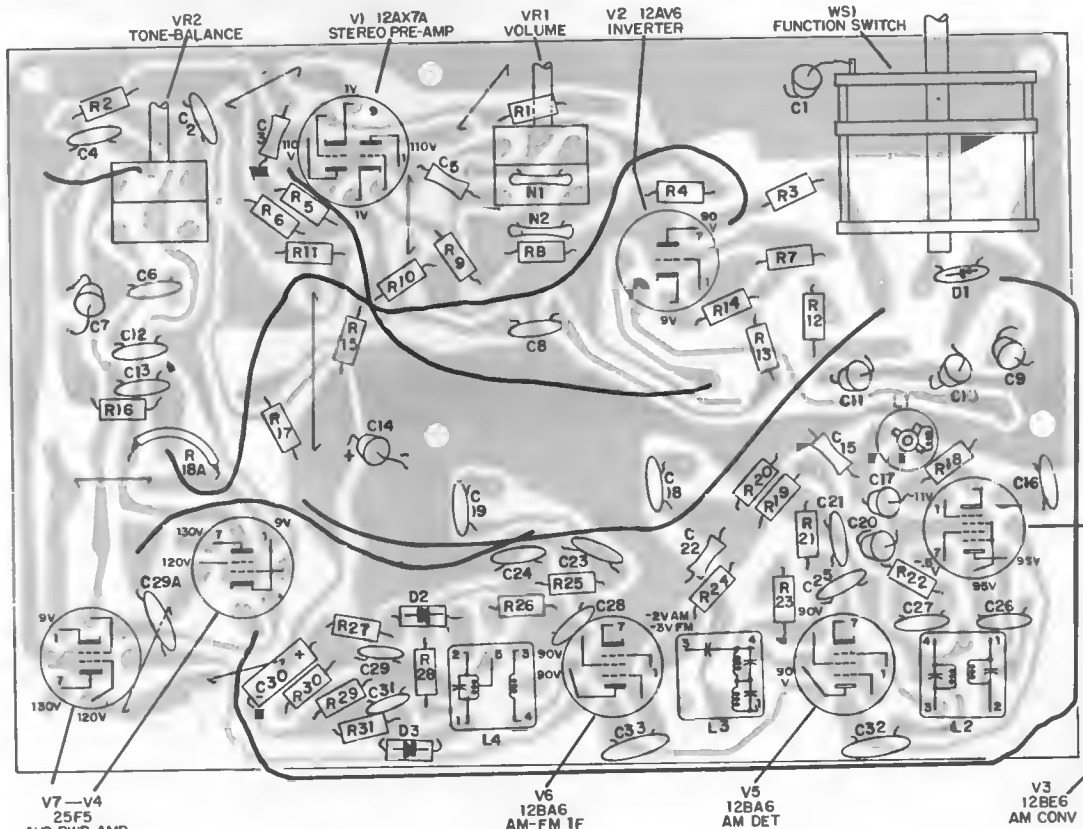

Bottom Perma-Circuit View, Parts Location, Model L-1651

PHILCO

MODELS L-1652 & L-1653
AMPLIFIER AND TUNER

(Continued)

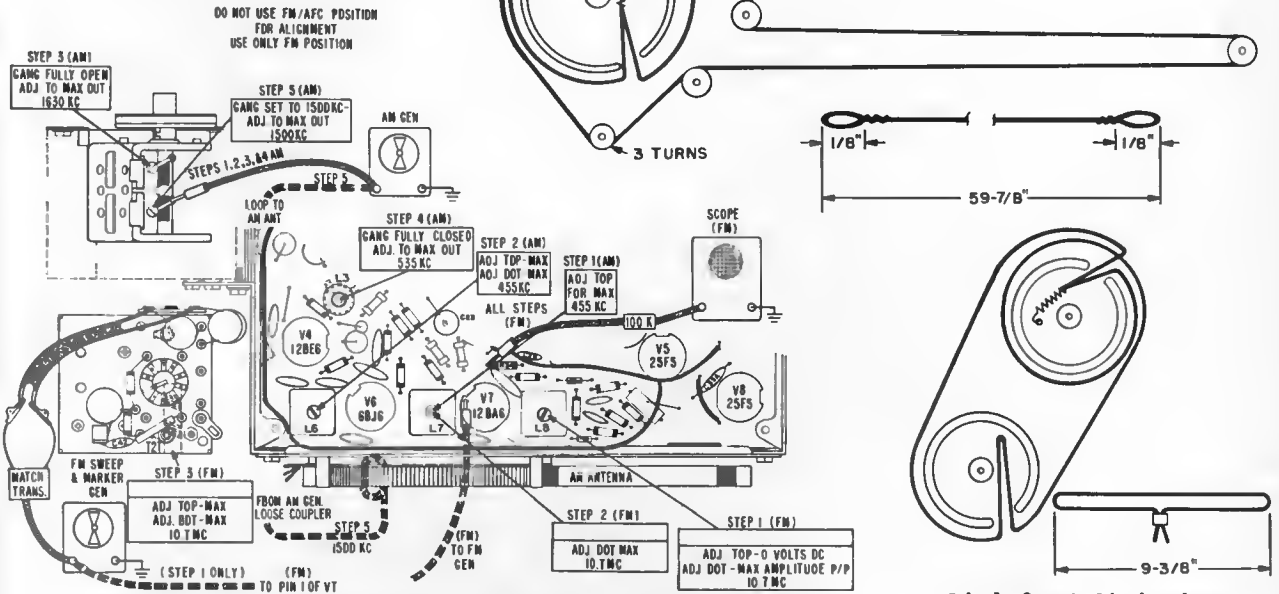

Alignment Procedure Chart, Models L-1652 & L-1653

Dial Cord Stringing

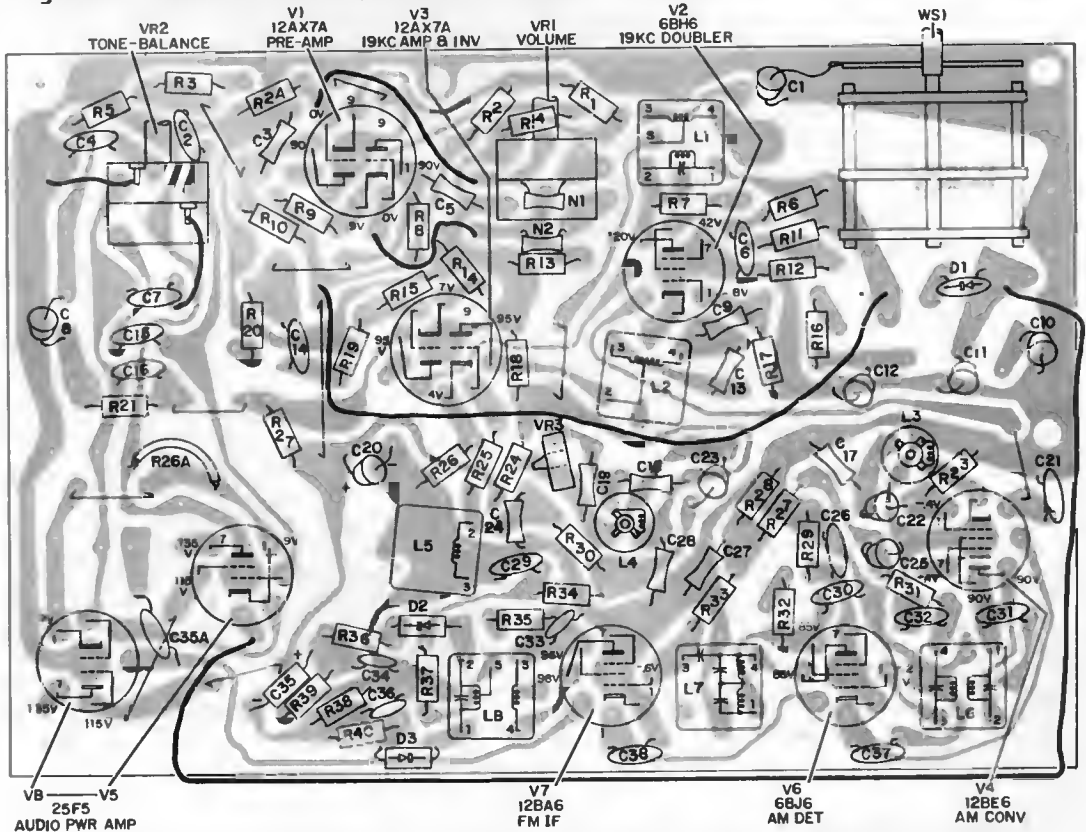

Bottom Perma-Circuit View Parts Location, Models L-1652 & L-1653

PHILCO Models L-1656, L-1667 & L-1679

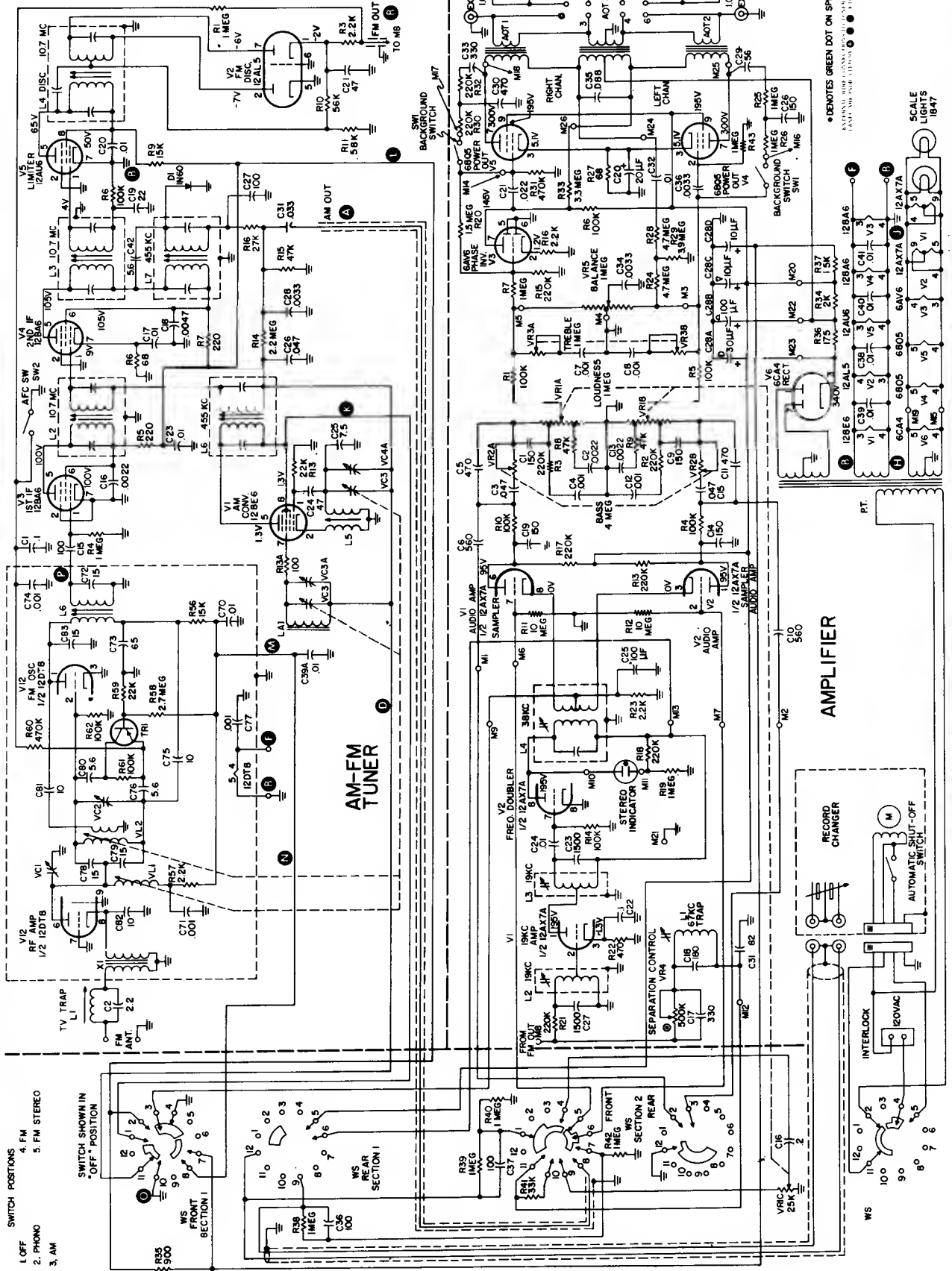

SWITCH POSITIONS
 1 OFF
 2 PHONO
 3 AM
 4 FM
 5 FM STEREO

SWITCH SHOWN IN OFF POSITION

WS FRONT SECTION I

WS REAR SECTION I

SECTION 2 FRONT

SECTION 2 REAR

SECTION 2 FRONT

SECTION 2 REAR

SECTION 2 FRONT

SECTION 2 REAR

SECTION 2 FRONT

SECTION 2 REAR

SECTION 2 FRONT

• DENOTES GREEN DOT ON SPEAKER

INTERNAL WIRE CONNECTIONS FROM PART 1

SCALE LIGHTS 1B47

Amplifier and Tuner Schematic Diagram, Models L-1656, L-1667 & L-1679

ALL VOLTAGES TAKEN WITH PRECISION VTVM MODEL 961. ALL CONTROLS SET AT MINIMUM AND SELECTOR SWITCHES SET TO PHONO OR FM POSITIONS.

VOLUME R-24, MOST-OFTEN-NEEDED 1964 RADIO SERVICING INFORMATION

PHILCO Models L-1656, L-1667, L-1679, (L-1731) Amplifier & Tuner (Continued)

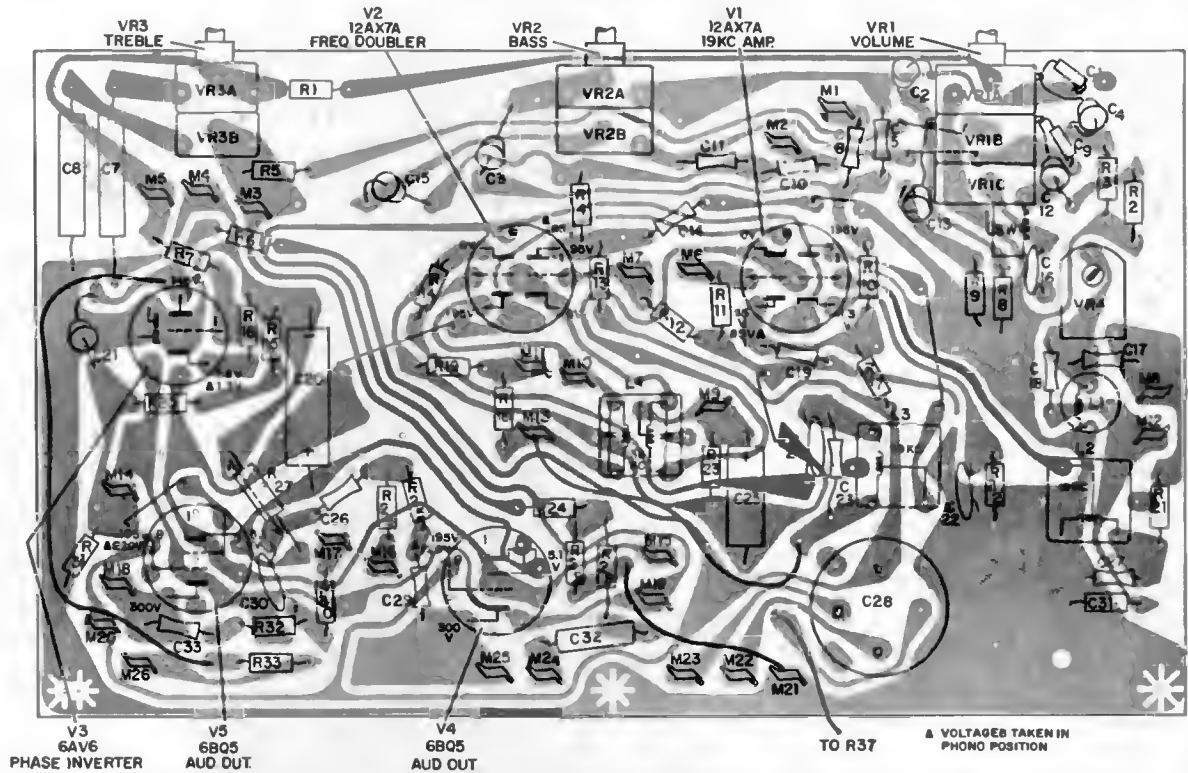

Bottom Perma-Circuit View, Parts Location, Models L-1656, L-1667 & L-1679

Amplifier perma-circuit panel was changed to Run 2 identified by a red dot. Panel changes consisted of removing wire jumper from Pin 1 of V1 to center tap of L3. Wire jumper was replaced with a 1K Ω resistor R16A. Resistor R18 was changed to 270K Ω . R14 was changed to 220K Ω . The copper foil connecting M10 and Pin 6 of V2 was opened. A 780K Ω resistor was soldered to the bottom of the panel from M10 to Pin 6 of V2. R19 was changed to a 1 megohm resistor.

Amplifier perma-circuit panel was changed to Run 3 identified by an orange dot. Panel changes consisted of removing wire jumper connecting Pin 2 of V5 to junction of M14, C21 and R31 and replacing with a 1K Ω resistor.

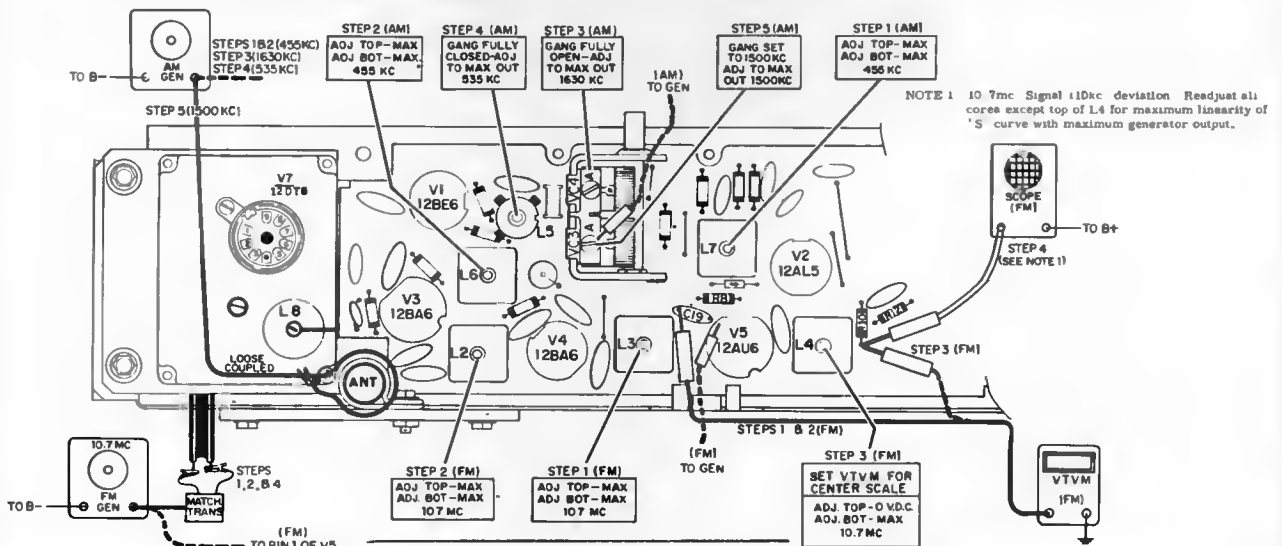

Alignment Procedure Chart AM-FM Tuner Models L-1656, L-1667, L-1679 & L-1731

RCA VICTOR

Chassis RS-202A, Models 3VC64, 3VC82, 4VC64, 4VC69, 4VC82,
and similar Chassis RS-202B, used in Models 4VE045, 4VE046.

ACCESS TO TUBES

All tubes are accessible through the small panel on the rear of the instrument.

1. Remove power cord.
2. Remove three (3) plated screws holding small access panel on rear of instrument.
3. Swing panel down and to right on its pivot. DO NOT ATTEMPT TO REMOVE PANEL.

CHASSIS REMOVAL

The top of the record changer compartment comprises the complete chassis. It rests on and is secured to a ledge at the front and is held by screws at the rear. The recommended procedure for its removal is as follows:

1. Remove knobs.
2. Open small access panel as described in "Access to Tubes."
3. Position two (2) holes in access panel over screws holding power cord interlock.
4. Remove two (2) machine screws holding interlock.

5. Pull record changer drawer down.
- If it is not desired to remove chassis completely, omit Steps 6 & 7.
6. Unscrew two (2) bolts securing record changer in access holes in turntable, one at front and one at rear.) drawer. (Lift mat of turntable and reach bolts through access holes in turntable, one at front and one at rear.) DO NOT ATTEMPT TO REMOVE RECORD CHANGER DRAWER.
7. Lift up changer and disconnect cables.
8. Remove four (4) plated screws holding front of chassis to horizontal ledge located inside of compartment at front of top.
9. Remove wires, running down each back corner of compartment, from holding clips.
10. Remove four (4) painted screws holding rear of chassis to rear of instrument—just below the access panel.
11. Chassis may then be lowered and removed.
12. Disconnect speaker cables from transformers and lift chassis out of case.

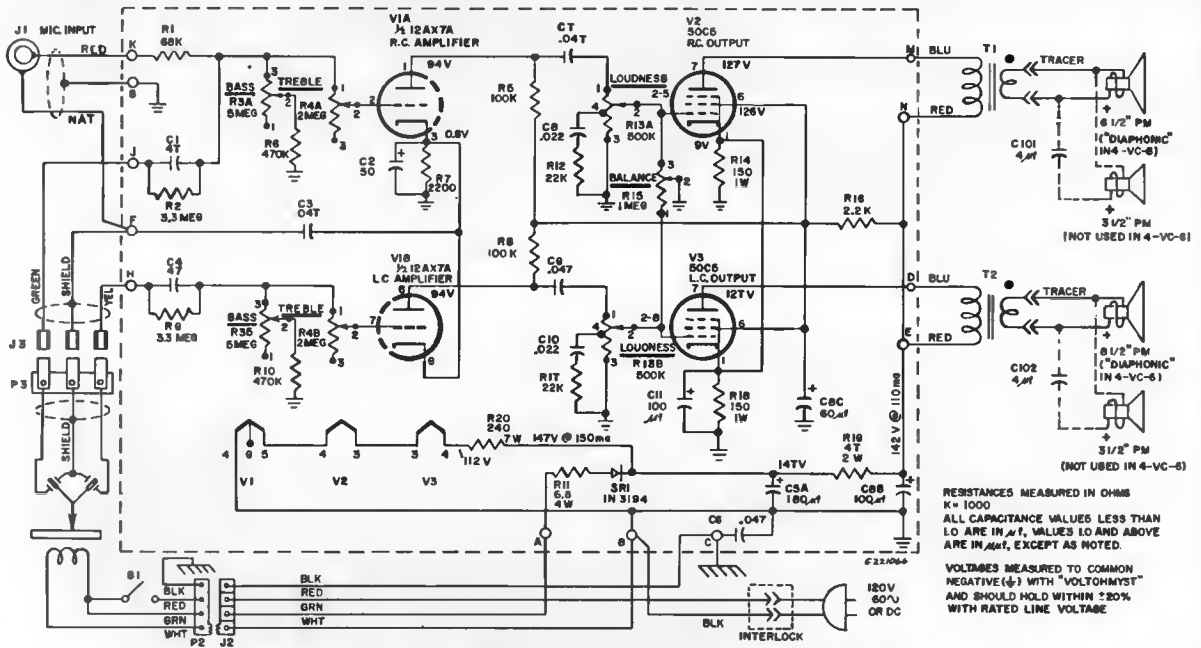

Wiring Board—View from Wiring Side

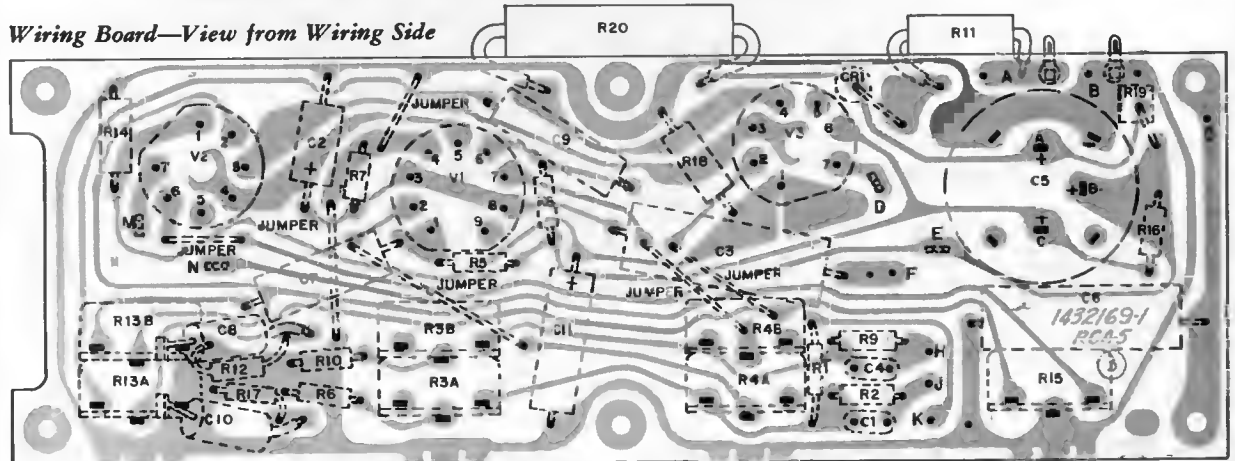

RCA VICTOR

4RA1 Series, Models 4RA10, 4RA14, 4RA15, Chassis RC-1213A,
 4RA3 Series, Models 4RA30, 4RA31, 4RA34, Chassis RC-1213B,
 4RA4 Series, Models 4RA41, 4RA42, 4RA45, Chassis RC-1213F,
 4RD4 Series, Models 4RD40, 4RD44, 4RD41, Chassis RC-1213H,
 4RD5 Series, Models 4RD51, 4RD52, 4RD55, Chassis RC-1213E.

(Service data below and continued on the next page at right)

CHASSIS ACCESSIBILITY

4RA1 and 4RD4 Series

1. DO NOT ATTEMPT TO REMOVE THE KNOBS. The tuning and volume control knobs are held captive to the cabinet by retainers on their shafts.
2. Remove the back cover by lifting the protrusions on the bottom of the back cover, out of the slots in the base of the cabinet.
3. Unsolder speaker leads if necessary. Avoid putting a strain on the speaker leads.
4. Remove two chassis retainers (screws or clips), one at the volume control and one on the left end mounting.
5. Grasp tuning capacitor and volume control, and pull chassis out of knobs and mounting slots.

4RA3 Series

1. IT IS NOT NECESSARY TO REMOVE THE KNOBS. The chassis, antenna, and loudspeaker are all mounted on the front panel section and are readily accessible when the back is removed.
2. Remove two (2) screws, one at each of the upper corners of the back.
3. Pull front panel section out of hood-back section.

To reassemble—

1. Align the power interlock connector.
2. Press the front and back sections of the cabinet together.
3. Check that the three bosses on the bottom of the front section are seated in their respective slots in the bottom of the back section.
4. Replace screws at upper back corners.

4RA4 and 4RD5 Series

1. IT IS NOT NECESSARY TO REMOVE THE KNOBS. The chassis, antenna, and loudspeaker are all mounted on the front panel section and are readily accessible when the back is removed.
2. Remove four (4) screws, one at each of the back corners.
3. Pull front panel section out of hood-back section.

To reassemble—

1. Align the power interlock connector.
2. Press the front and back sections together.
3. Replace four screws in back corners.

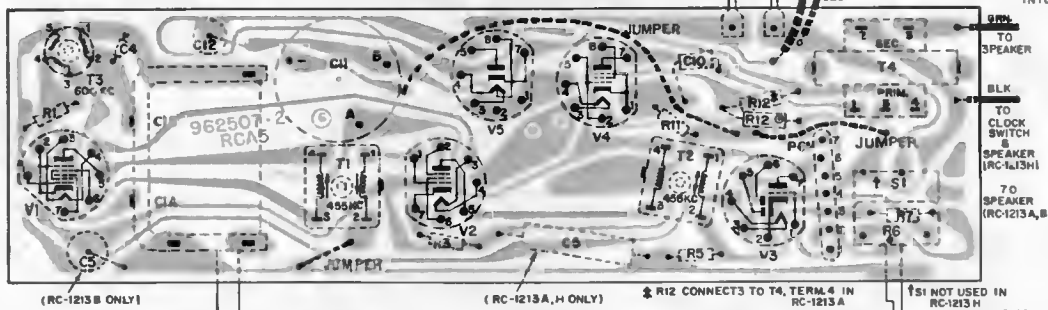
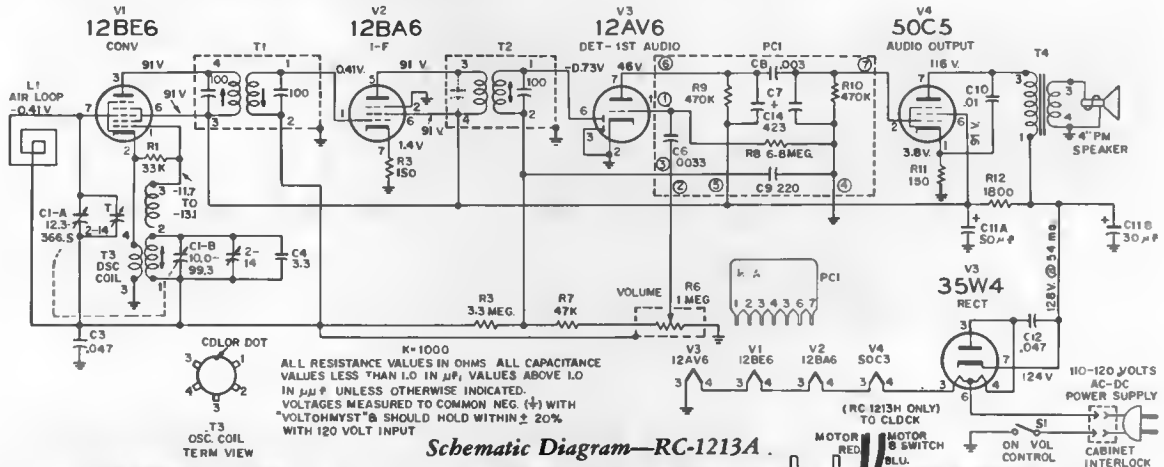

RCA Victor Chassis RC-1213A, -B, -E, -F, -H, Continued from preceding page.

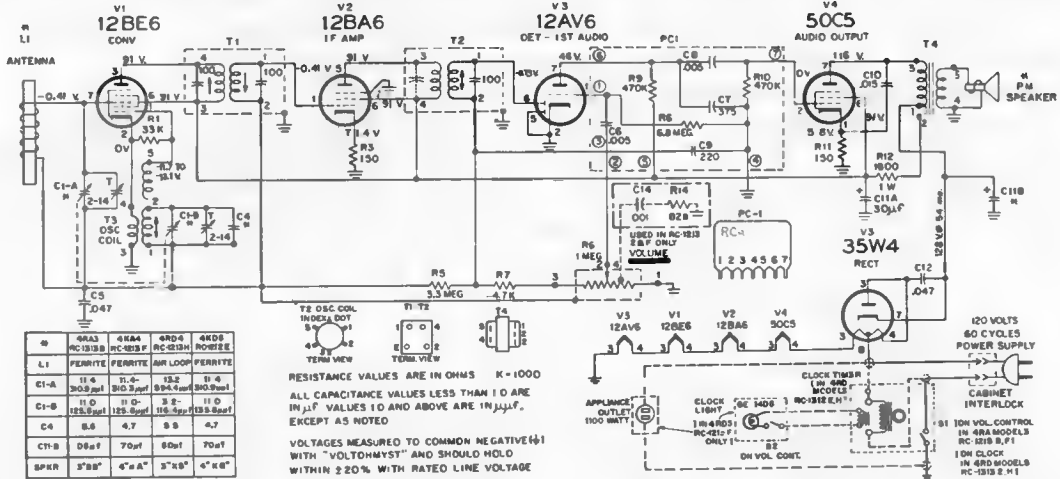

Schematic Diagram—RC-1213B, E, F, H

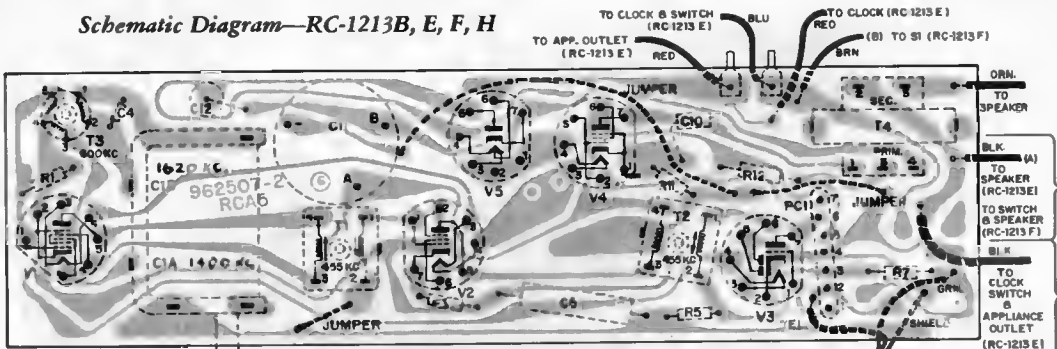

Chassis Layout—RC-1213E, F View from Wiring Side

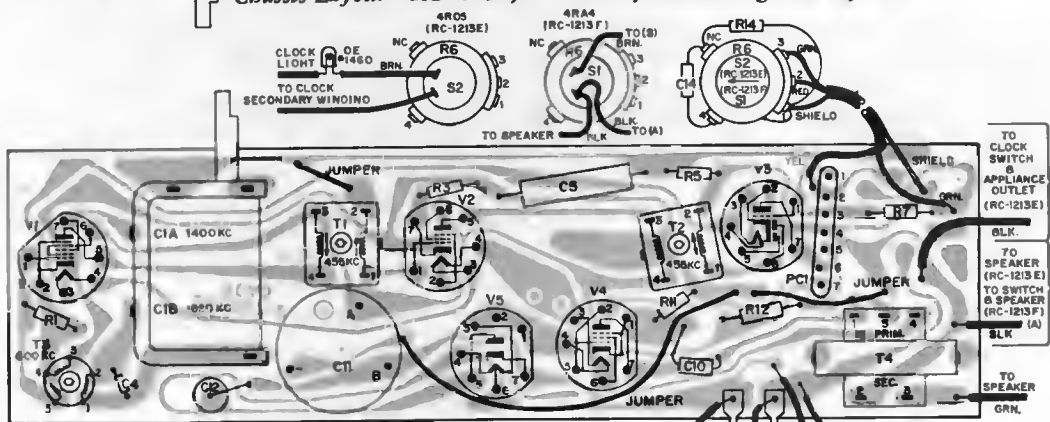

Chassis Layout—RC-1213E, F View from Component Side

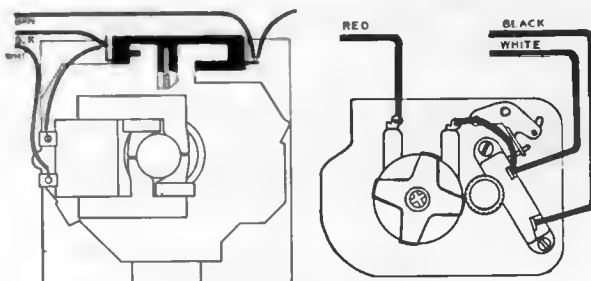

Clock Wiring

Dial Cord Stringing

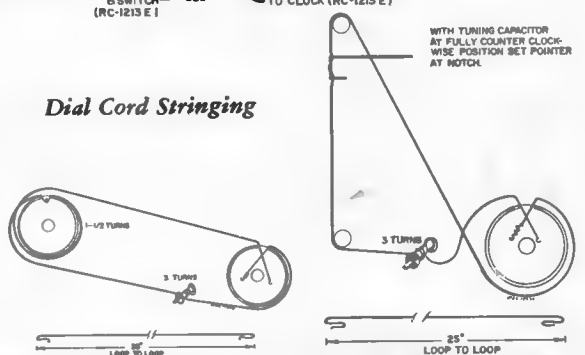

VOLUME R-24, MOST-OFTEN-NEEDED 1964 RADIO SERVICING INFORMATION

RCA VICTOR Models 3VF305, 3VF306, 3VF340, 3VF346, 3VF349, employ Tuner Chassis RC-1205C and Amplifier Chassis RS-199B; while Models 3VF405, 3VF446, 3VF516, 3VF534, 3VF604, 3VF619, 3VF646, use the same Tuner and Amplifier Chassis RS-177H. Service material below and on the next two pages.

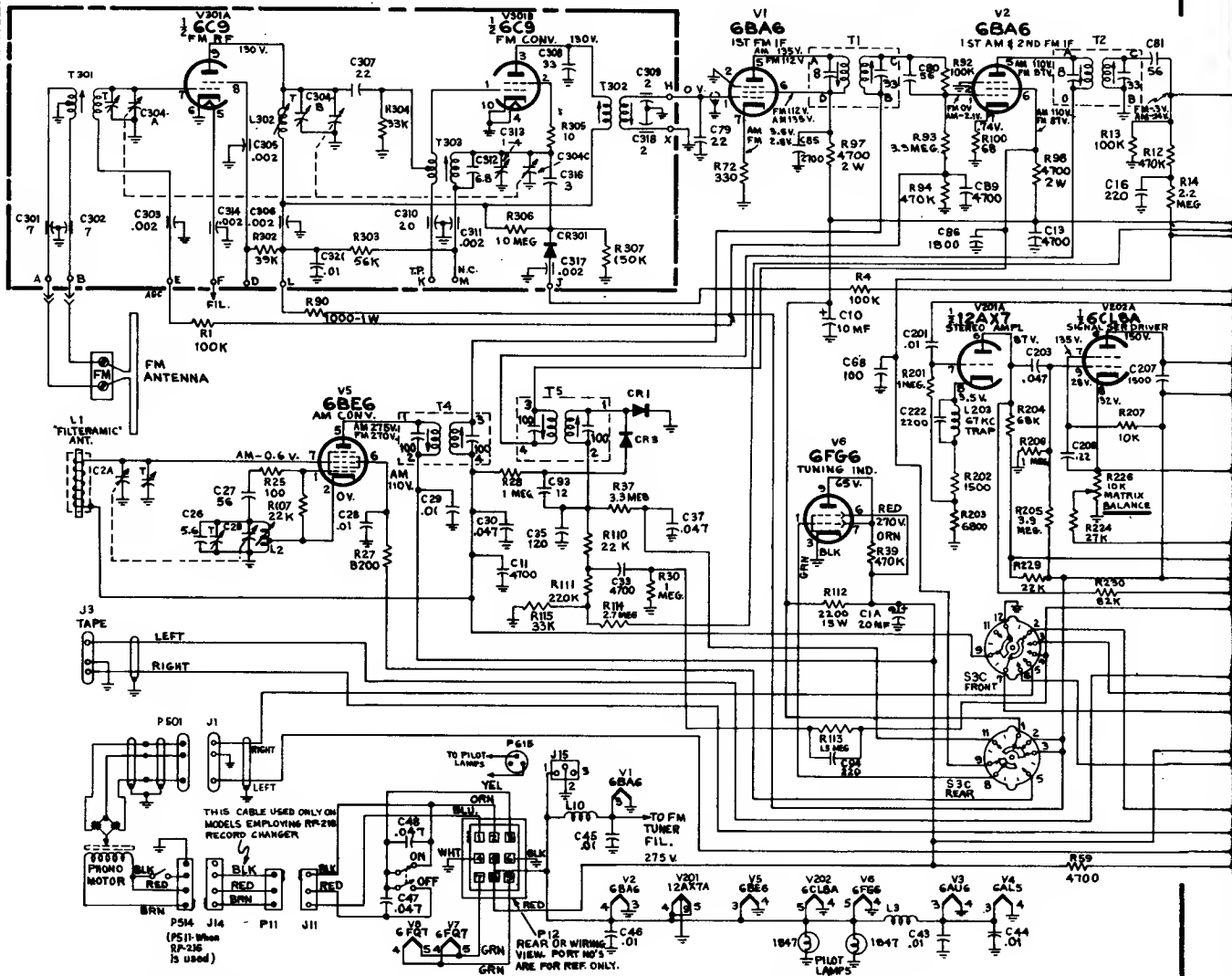

Dial Cord Stringing

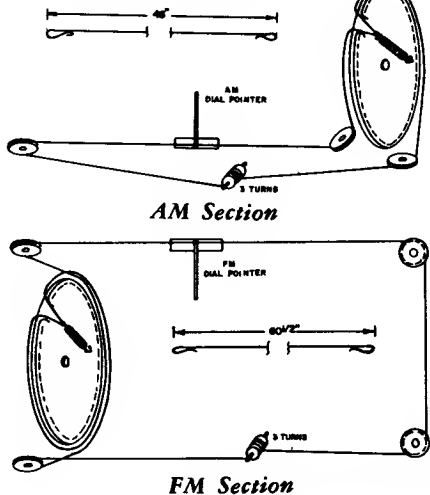

CRITICAL LEAD DRESS

RC-1205C

1. Dress R3 and R9 up and away from all other components.
2. Keep 10.7 mc IF grid and plate wiring short and close to chassis.
3. Dress L3 close to chassis.
4. Keep heater leads away from audio grid circuits.
5. Dress C46 and C48 and AC wiring up and away from audio components.

RS-177H

1. Dress all heater leads flat along bottom of chassis.
2. Use minimum lead length on all resistors between V401 and V402 and terminal board.
3. Dress feed back leads between terminal board near output transformers and V401 and V402, along inside corner of chassis and then along back side of terminal board near V401 and V402.
4. Dress plate leads from output transformers to output tubes down center of chassis away from feed back leads.
5. Dress power resistors R426, R427, and R428 well away from chassis. All insulated leads are to be dressed away from these resistors.

VOLUME R-24, MOST-OFTEN-NEEDED 1964 RADIO SERVICING INFORMATION

RCA VICTOR Continuation of service material on Tuner Chassis RC-1205C, for list of models using this chassis see preceding page at left, material on Amplifier Chassis RS-177H and RS-199B is on the next page, over.

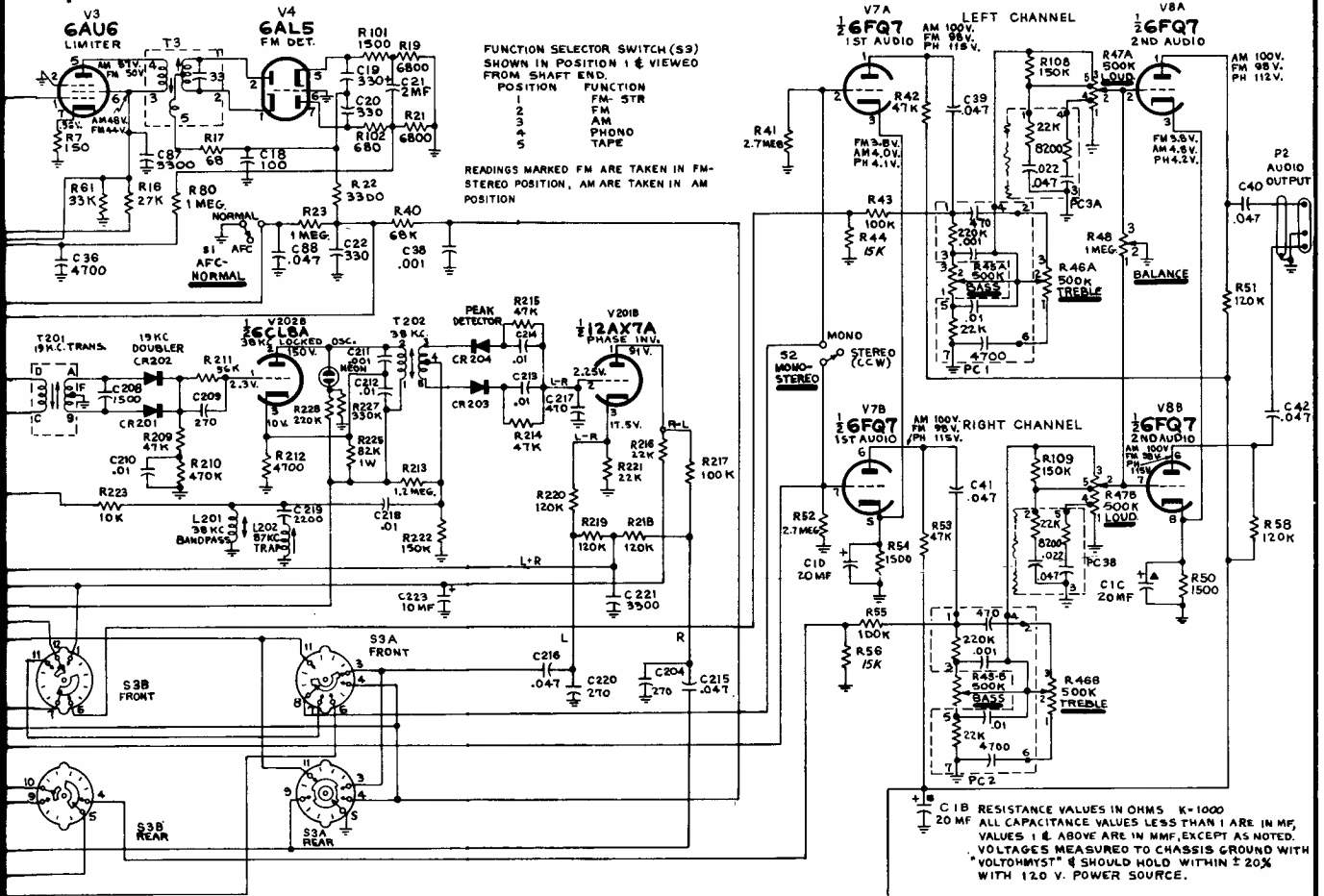

SPEAKER PHASING

The two speaker systems must be properly connected in order to have "in-phase" sound outputs. Incorrect connections will be evidenced by "loss of bass" or distortion in the sound when playing a monophonic recording and listening

from a point midway between the two speaker systems. Similarly the speakers in each system must be phased with each other.

To maintain correct phasing, the speaker connections as shown should be closely followed.

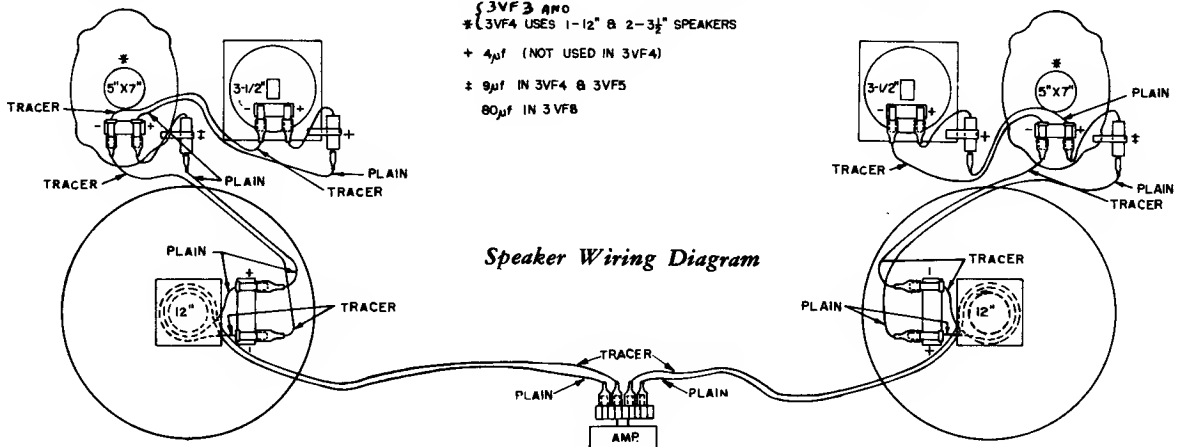

VOLUME R-24, MOST-OFTEN-NEEDED 1964 RADIO SERVICING INFORMATION

RCA VICTOR Amplifier Chassis RS-177H and RS-199B, for list of models using these chassis, associated tuner data, etc., see preceding two pages.

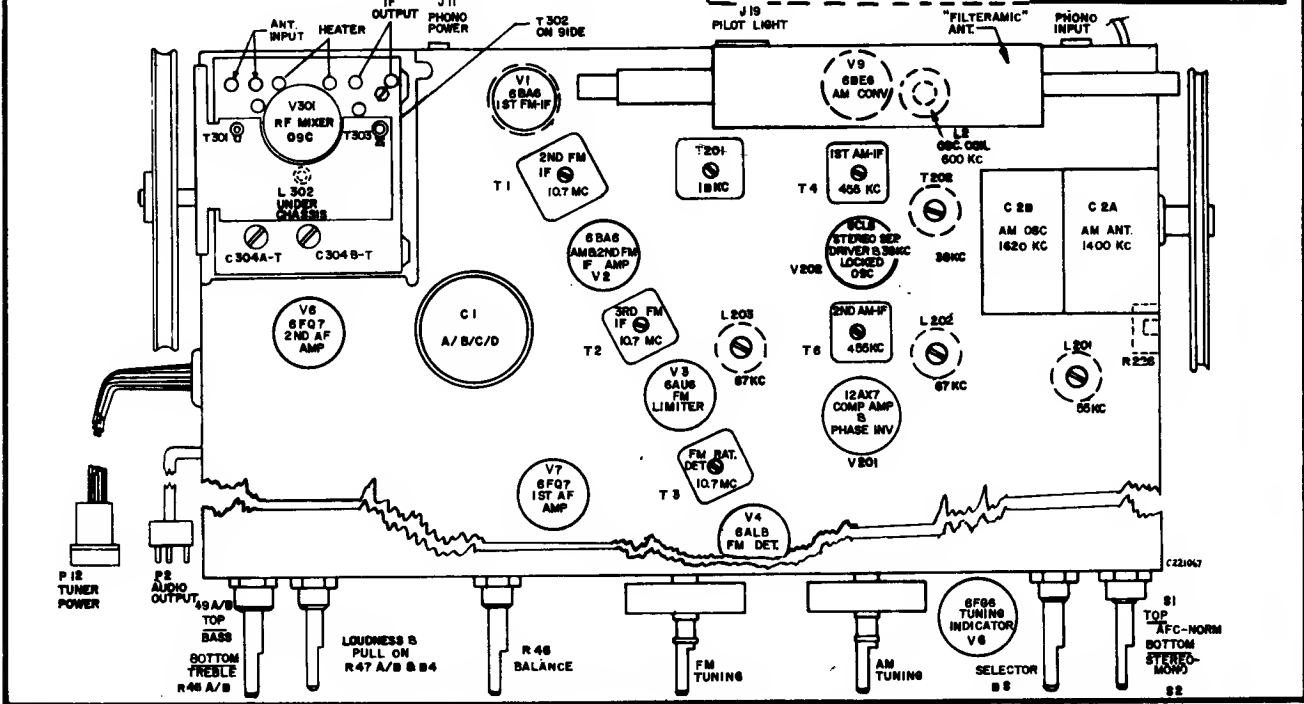
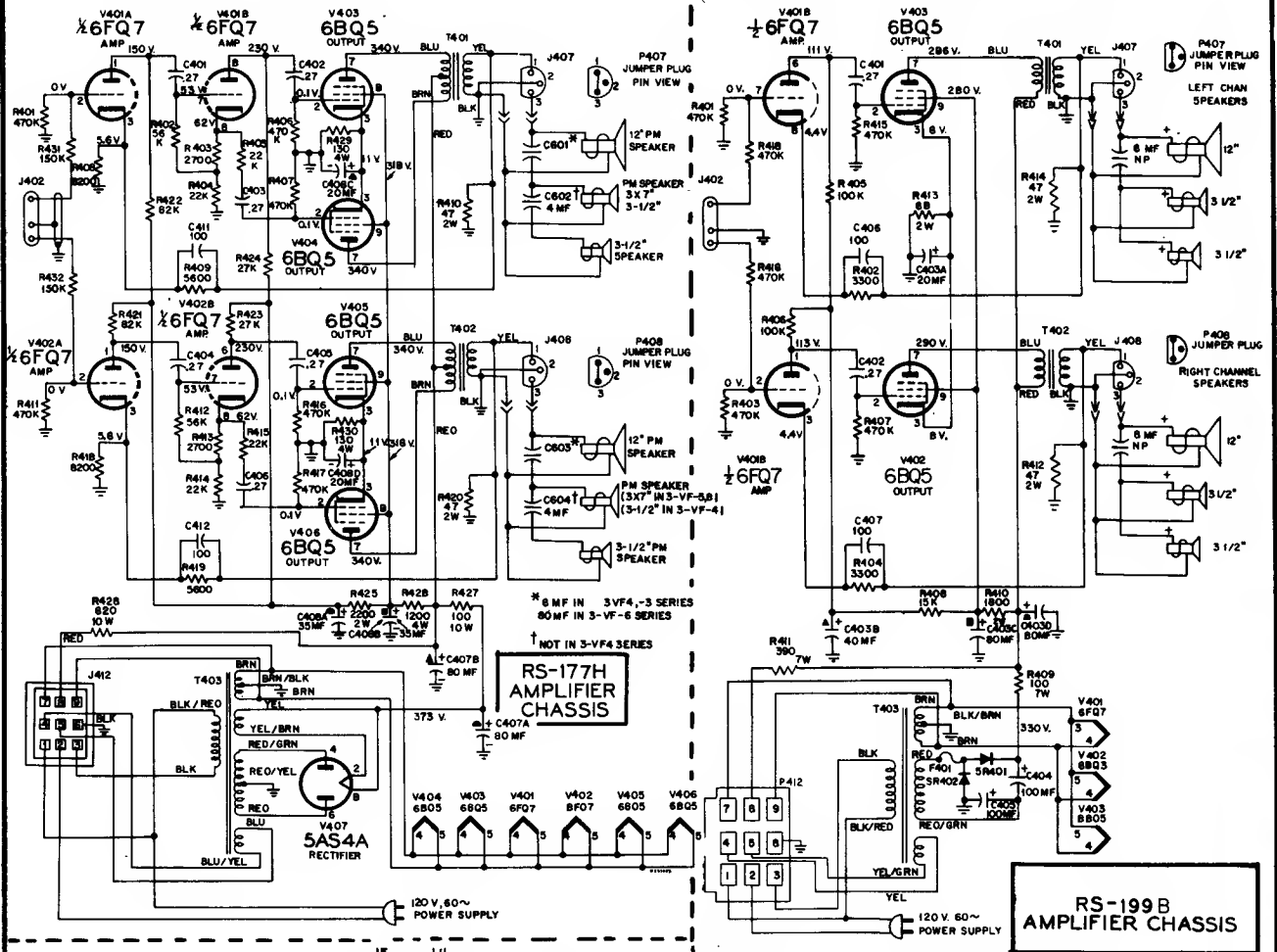

RCA VICTOR

4RG1 Series, Models 4RG11, 4RG12, 4RG16, Chassis RC-1208D
 4RG3 Series, Models 4RG31, 4RG34, Chassis RC-1208H

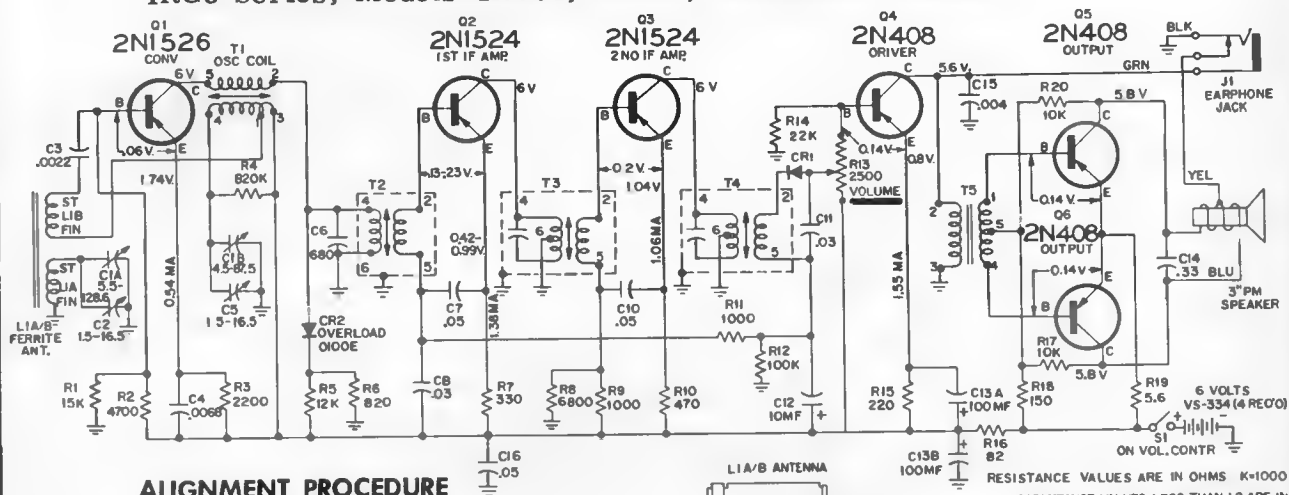

ALIGNMENT PROCEDURE

Step	Connect High Side of Signal Generator to—	Signal Gen. Output	Dial Pointer Setting	Adjust for Max. Output
1	Antenna gang stator C1A thru .01 mf capacitor	455 kc	Gang fully open	T4 (3rd I-F)
2				T3 (2nd I-F)
3				T2 (1st I-F)
4	Repeat Steps 1, 2, and 3			
5	Short wire placed near antenna far radiated signal	1620 kc	Gang fully open	Oscillator trimmer C5
6		1400 kc (rock gang if necessary)	1400 kc (rock gang if necessary)	Antenna trimmer C2
7		600 kc (rock gang)	600 kc (rock gang)	T1 osc. coil
8	Repeat Steps 5, 6, and 7.			

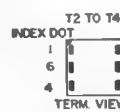
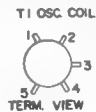
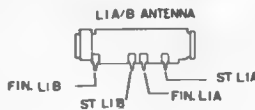

RESISTANCE VALUES ARE IN OHMS K=1000
 ALL CAPACITANCE VALUES LESS THAN 10 ARE IN MF, THOSE ABOVE 10 ARE IN MMF EXCEPT AS NOTED.
 VOLTAGES MEASURED WITH "VOLTOMYST" FROM BATTERY (+) & SHOULD WITHIN ± 20% WITH A NEW BATTERY

CHASSIS REMOVAL

Remove tuning knob. Open case
 Remove two screws—one at each corner—located near antenna. Remove two screws located between positive battery contacts.
 If speaker is connected to board by wires, unsolder wires at board.
 Lift slightly the end of each board that was secured by screws and slide boards out of slots which hold opposite ends.

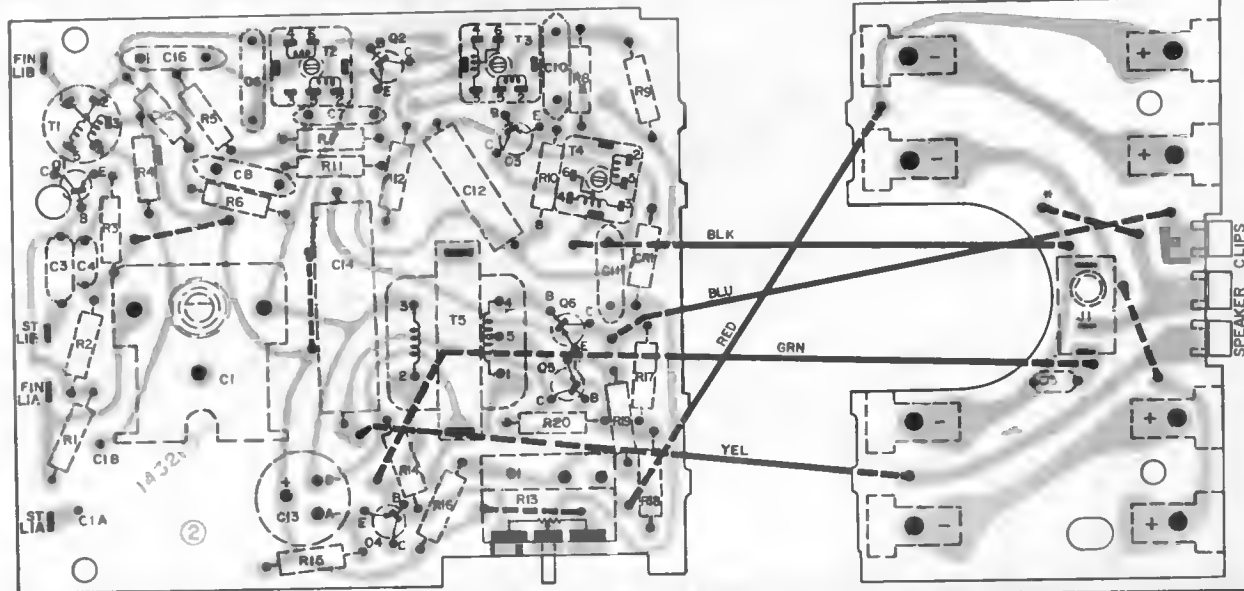

RCA VICTOR

Models 4VF304, 4VF325, 4VF326, 4VF348, 4VF349, 4VF405, 4VF446, 4VF464, 4VF480, 4VF488, 4VF534, use Tuner Chassis RC-1211A covered across these two pages, and Amplifier Chassis RS-177J or RS-199C which are very similar to amplifier chassis of the number (but different suffix) covered on the preceding page.

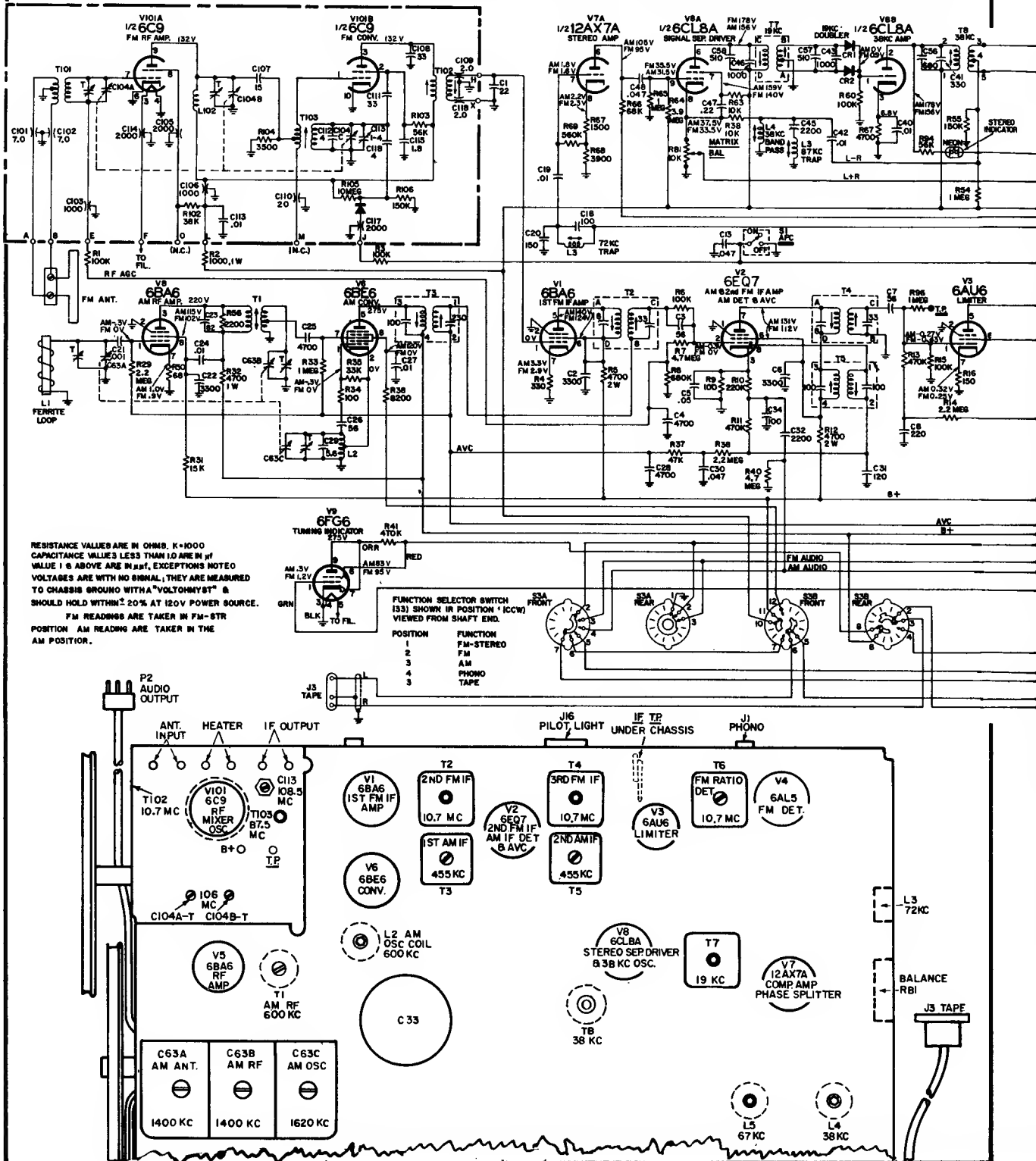

RCA VICTOR

Models 4VF304, 4VF325, 4VF326, 4VF348, 4VF349, 4VF405, 4VF446, 4VF464, 4VF480, 4VF488, 4VF534, use Tuner Chassis RC-1211A covered across these two pages, and Amplifier Chassis RS-177J or RS-199C which are similar to amplifier chassis of corresponding number (but different suffix) of previous section.

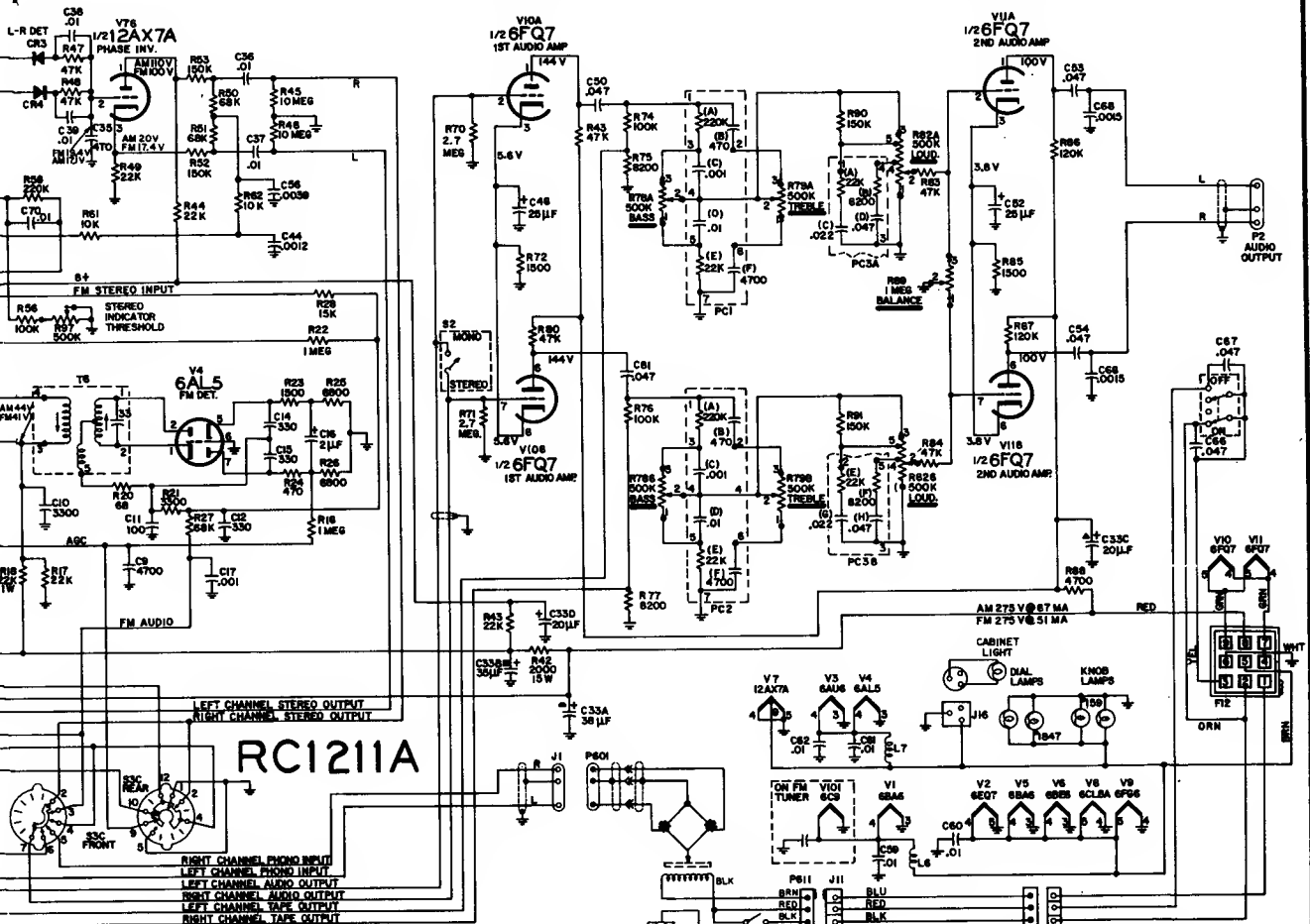

RC1211A

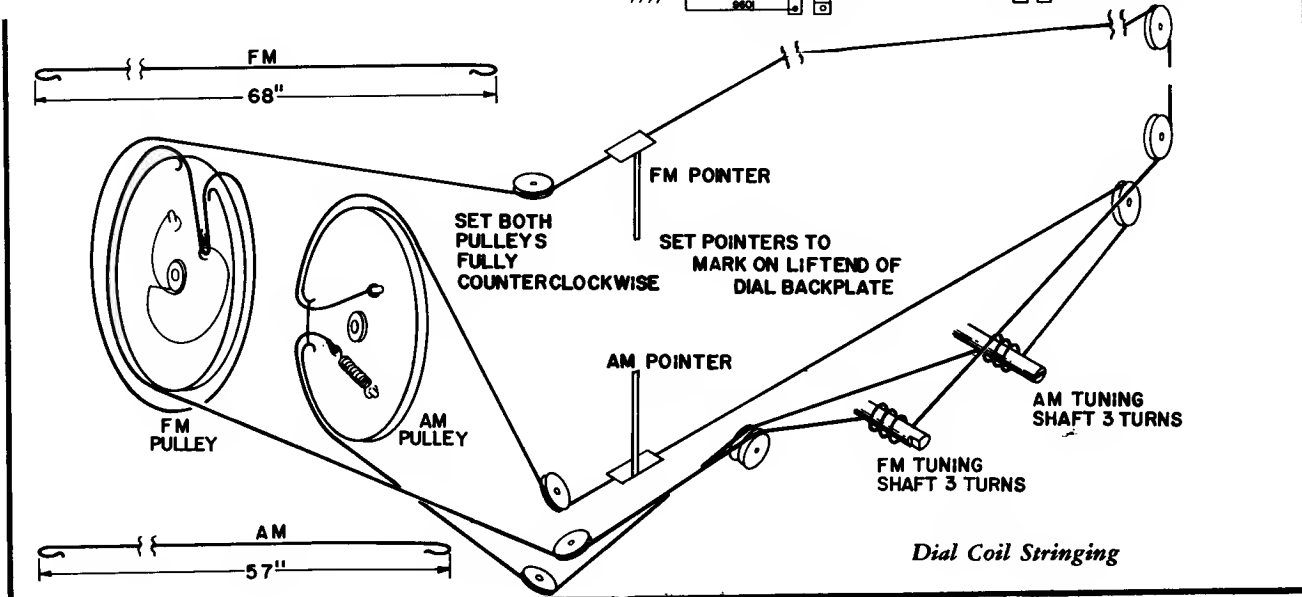

Dial Coil Stringing

VOLUME R-24, MOST-OFTEN-NEEDED 1964 RADIO SERVICING INFORMATION

RCA Victor Models 4VF095, 4VF096, 4VF105, 4VF106, 4VF114, 4VF124, 4VF145, 4VF146, 4VF155, 4VF156, 4VF206, 4VF224, 4VF282, 4VF289, use Chassis RC-1215A & B Tuner and Amplifier Chassis RS-203A, schematics across these two pages and other service material on the page following.

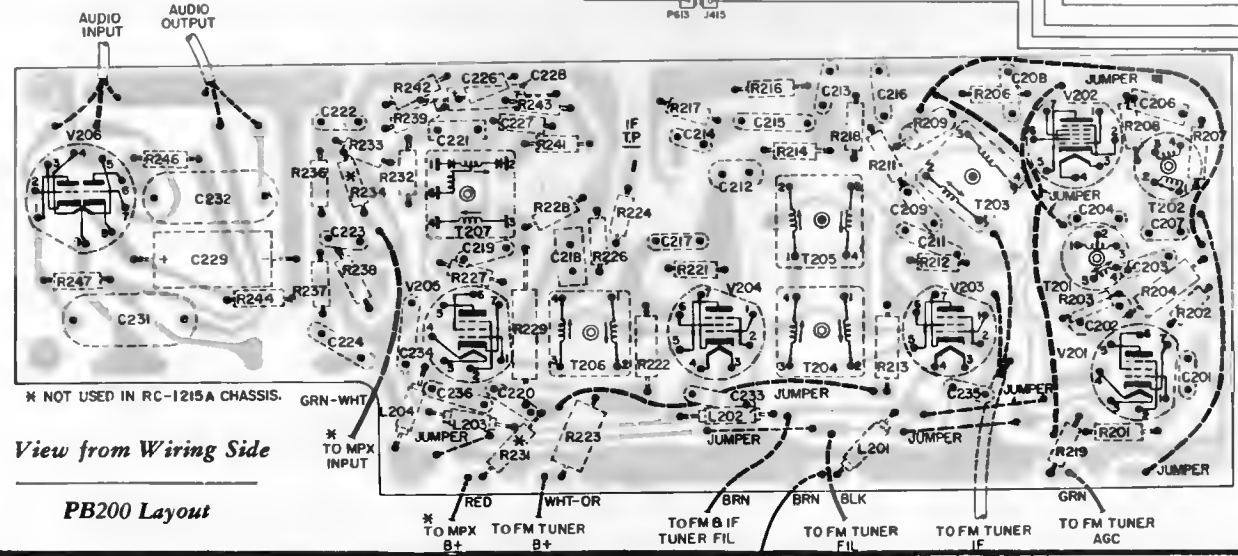
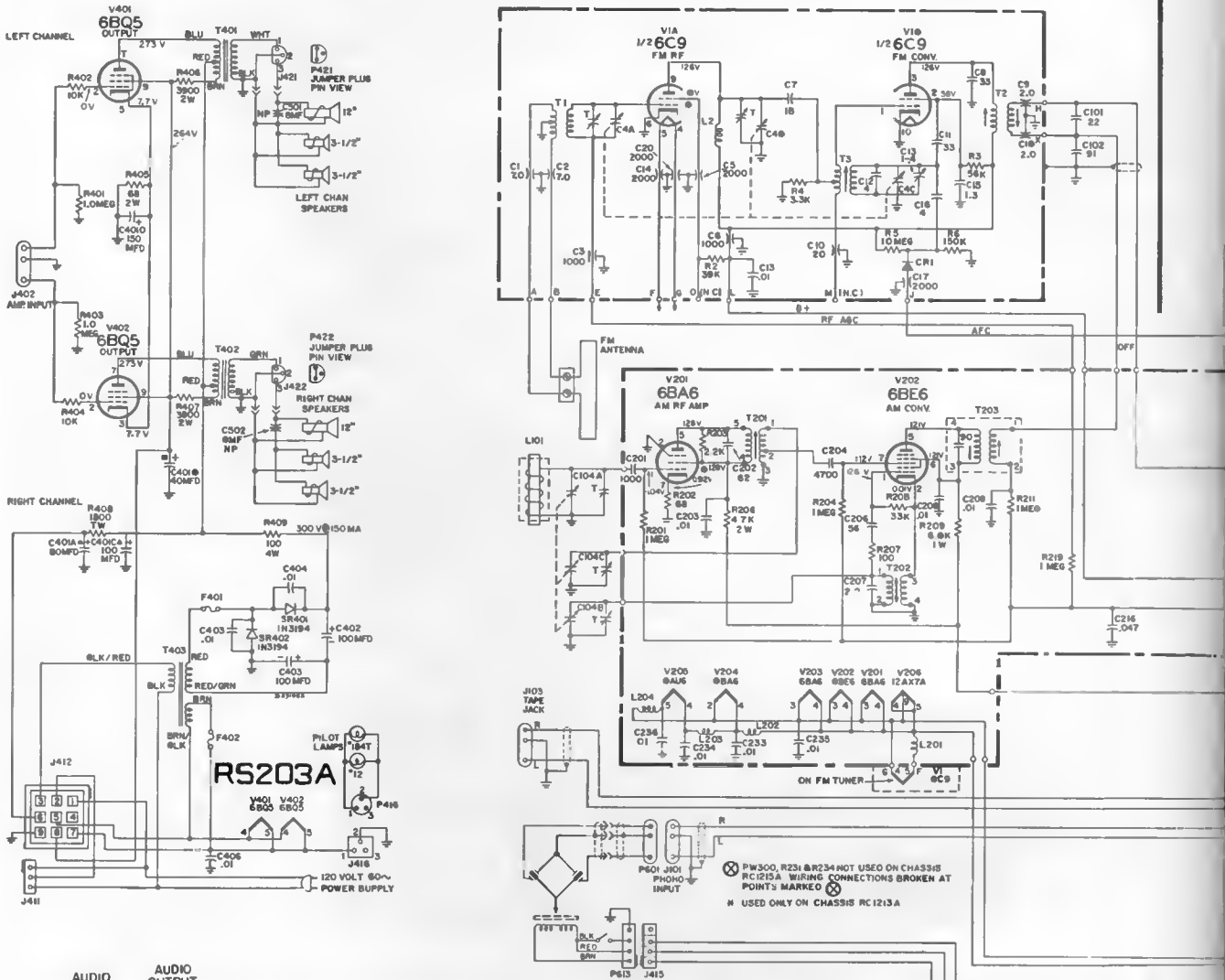

VOLUME R-24, MOST-OFTEN-NEEDED 1964 RADIO SERVICING INFORMATION

RCA Victor Models 4VF095, 4VF096, 4VF105, 4VF106, 4VF114, 4VF124, 4VF145, 4VF146, 4VF155, 4VF156, 4VF206, 4VF224, 4VF282, 4VF289, use Tuner Chassis RC-1215A & B and Amplifier Chassis RS-203A, schematics printed across these two pages and other material on the page following.

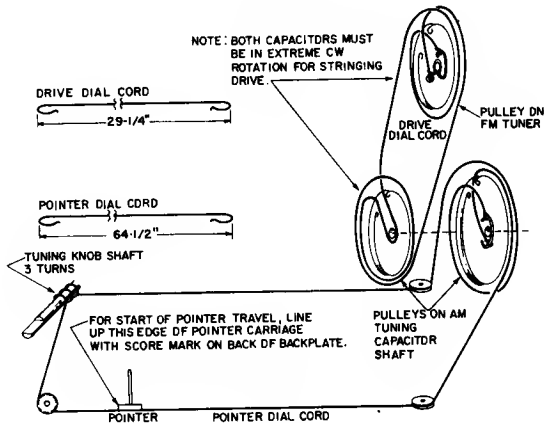
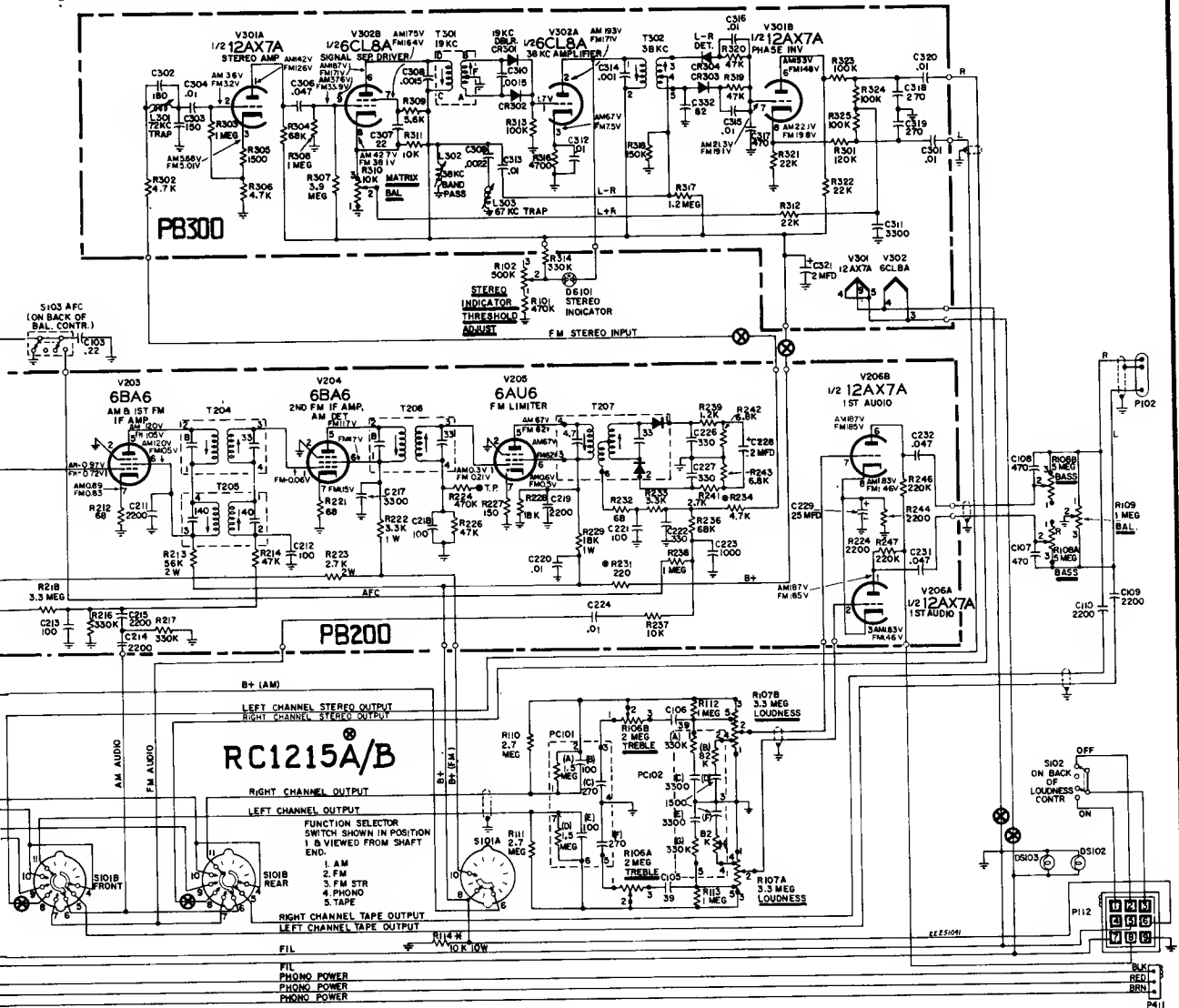

Dial Cord Arrangement

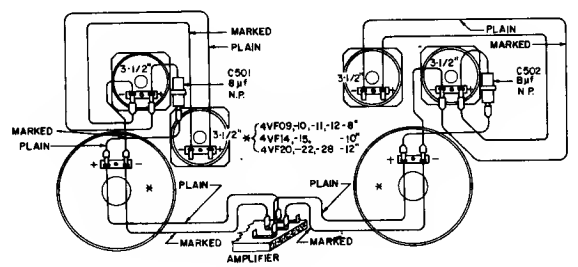

Speaker Wiring

VOLUME R-24, MOST-OFTEN-NEEDED 1964 RADIO SERVICING INFORMATION

RCA Victor Models 4VF095, 4VF096, 4VF105, 4VF106, 4VF114, 4VF124, 4VF145, 4VF146, 4VF155, 4VF156, 4VF206, 4VF224, 4VF282, 4VF289, use Tuner Chassis RC-1215A & B, Amplifier RS-203A, material continued.

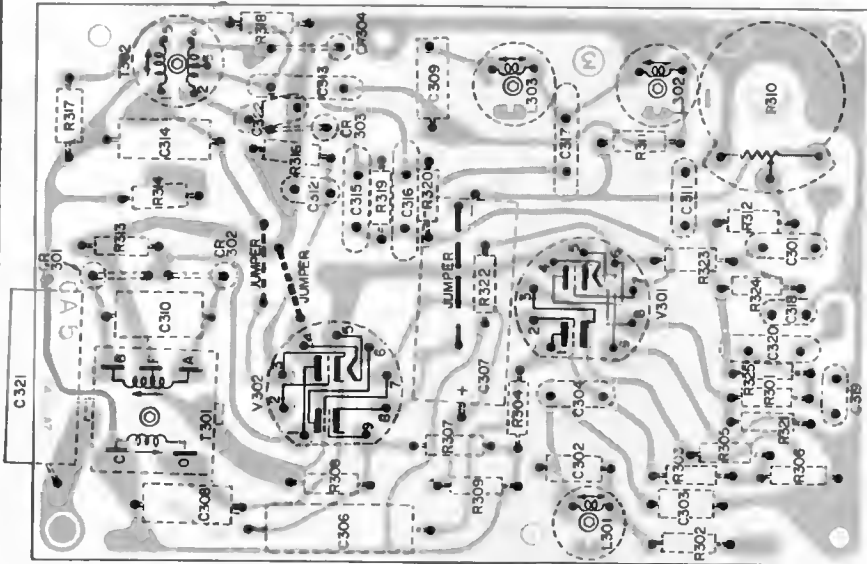

PB300 Layout

View from Wiring Side

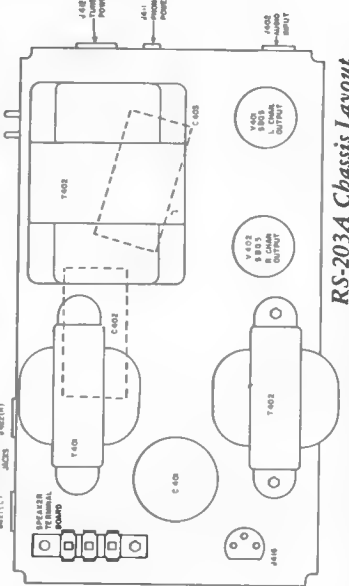

RS-203A Chassis Layout

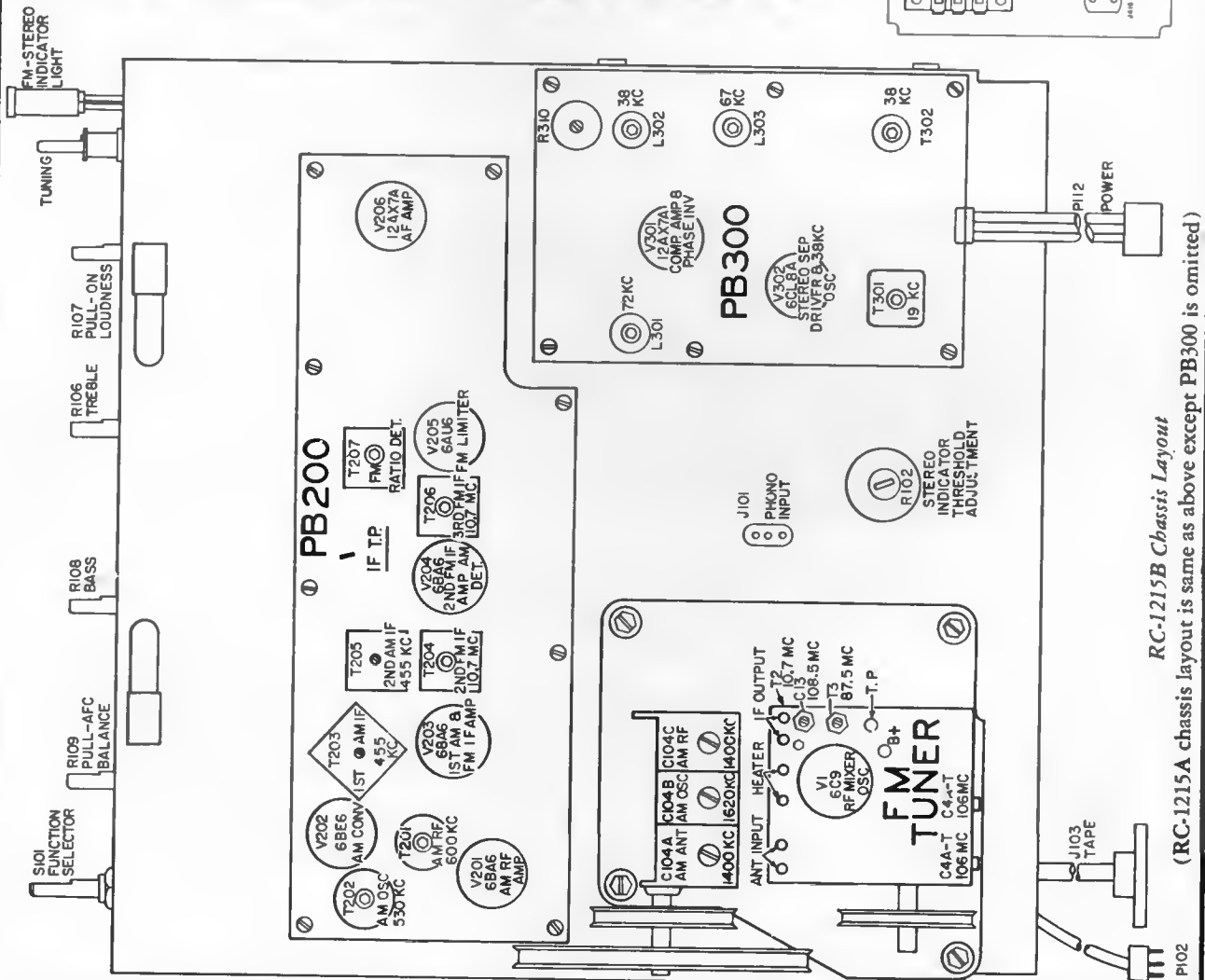

RC-1215B Chassis Layout

(RC-1215A chassis layout is same as above except PB300 is omitted)

RCA VICTOR

4RG6 Series, Models 4RG61, 4RG62, 4RG66, Chassis RC-1214A;
 4RG5 Series, Models 4RG51, 4RG52, 4RG56, also use the same chassis and are electrically the same, but are positioned differently in the case and do not use a dial light.

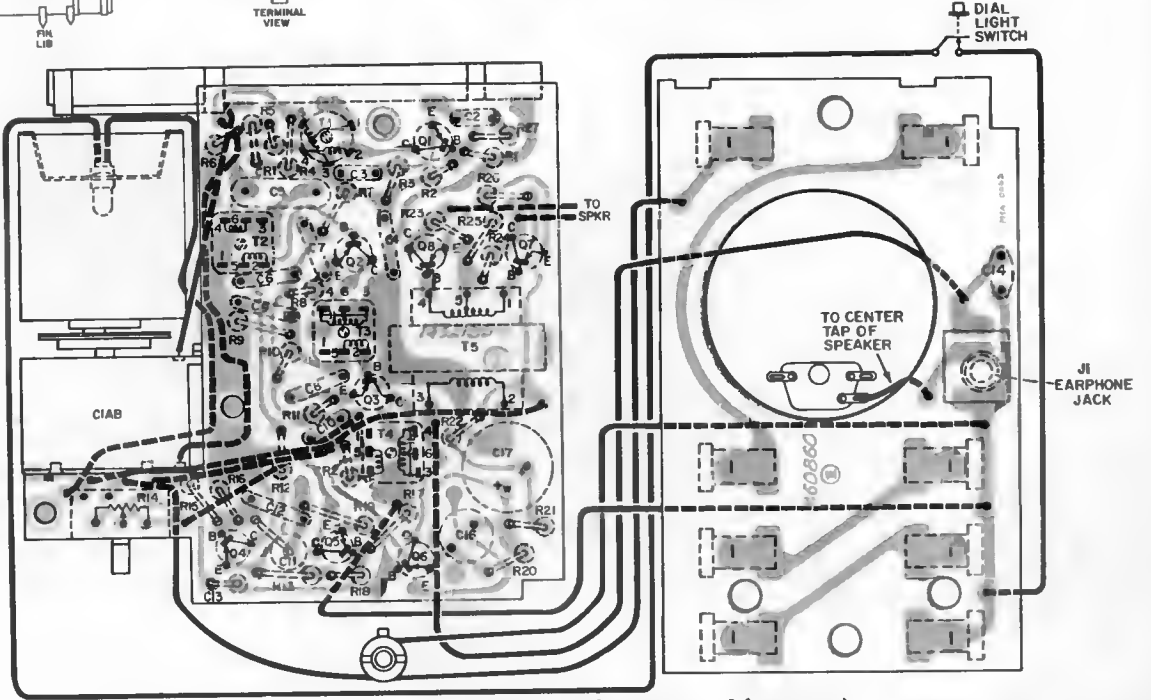
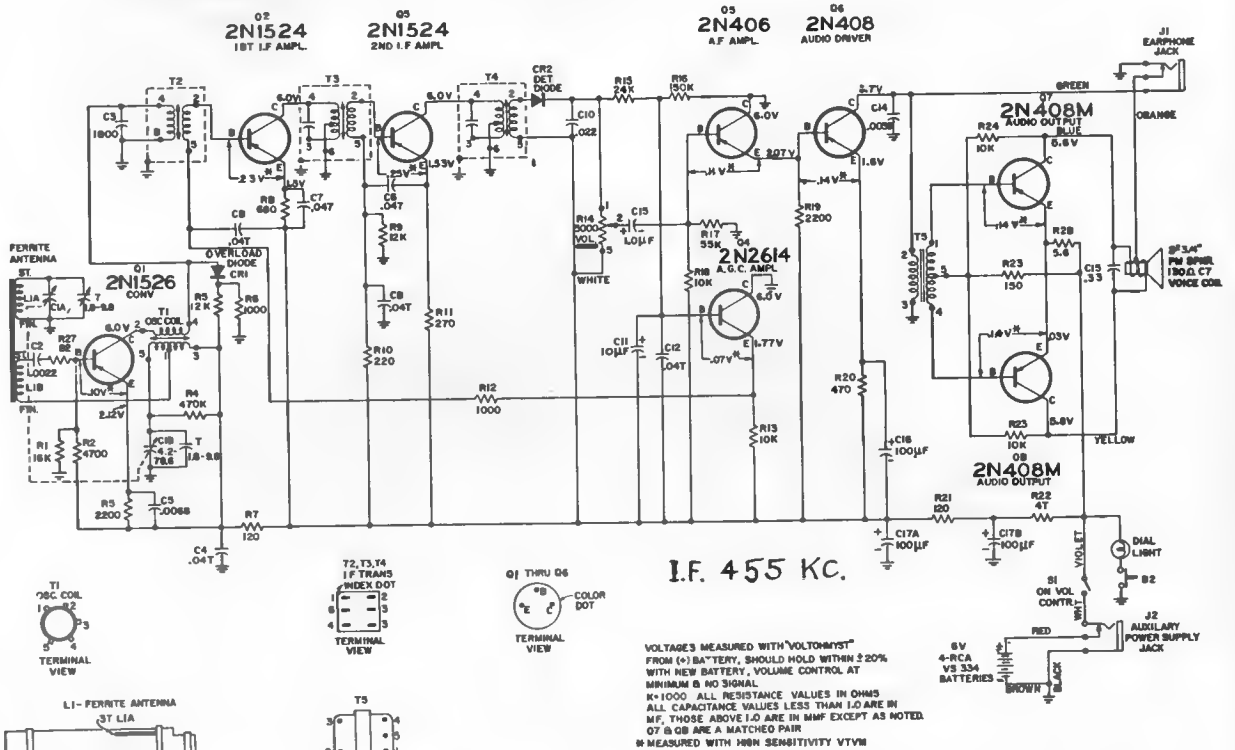

RC-1214A Chassis Layout, Wiring Side (removed from case)

SEARS, ROEBUCK AND CO.

Silvertone

CHASSIS 132.75901
MODEL 4001, 4002, 4003

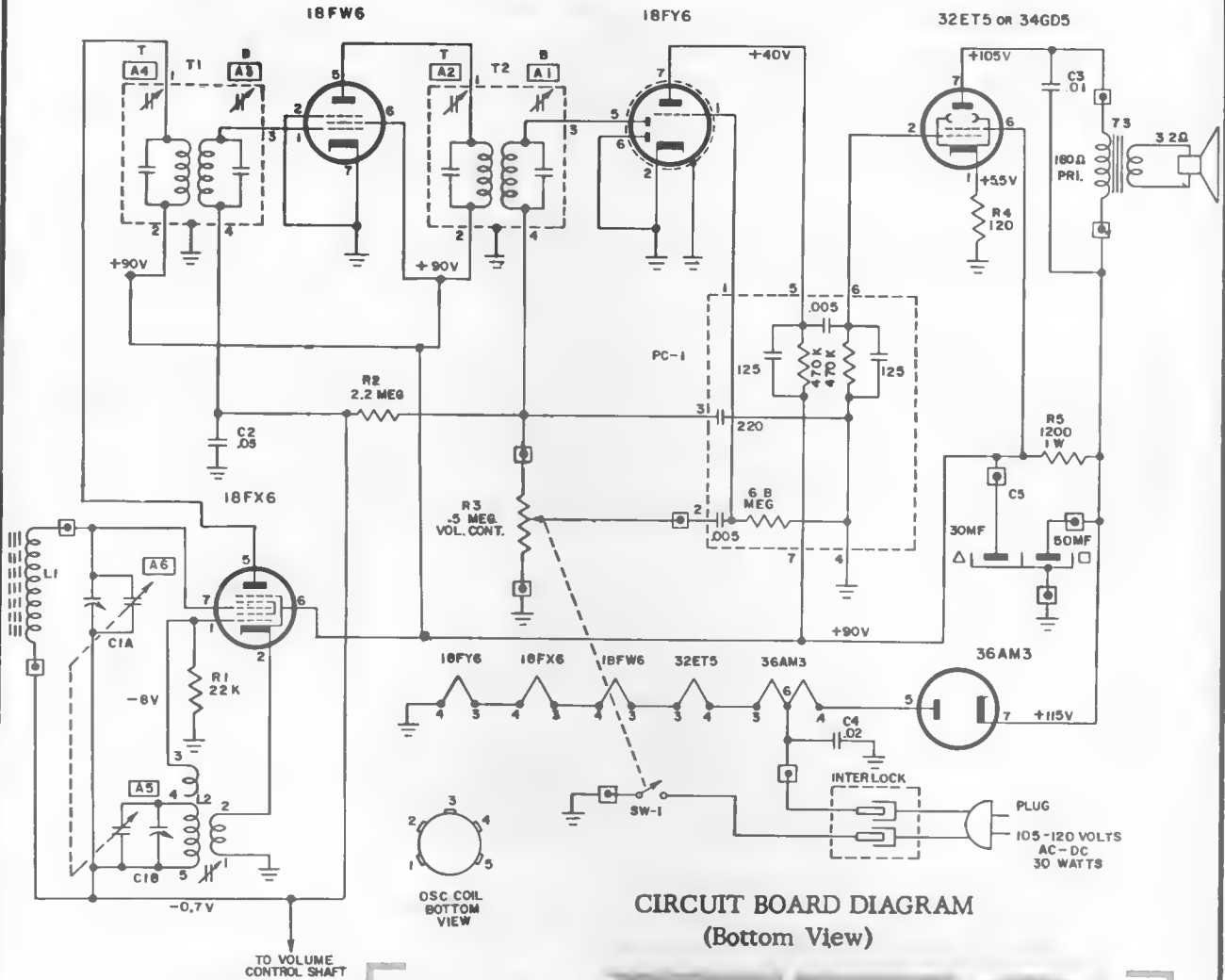

CIRCUIT BOARD DIAGRAM
(Bottom View)

⊥ = B-
□ = EXTERNAL CONNECTIONS TO PRINTED BOARD
VOLTAGES MEASURED WITH A VTVM
RESISTANCE VALUES ARE IN OHMS R = 1,000,
MEG = 1,000,000
CAPACITANCE VALUES LESS THAN (1) ARE IN
MICROFARADS (μF) AND VALUES OF (1) OR
GREATER ARE IN MICROFARADS (μF),
UNLESS OTHERWISE INDICATED.

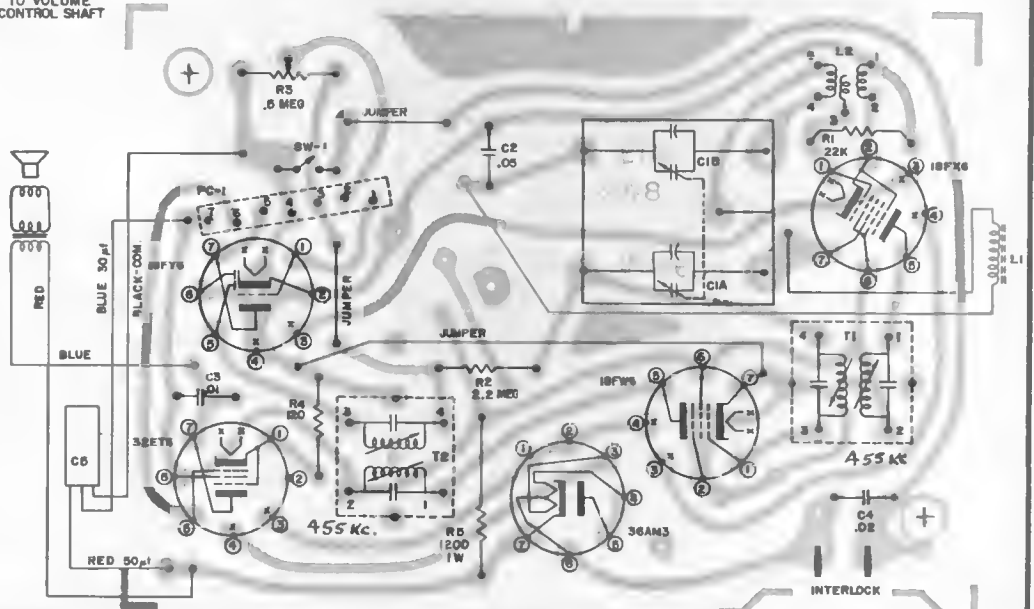

VOLUME R-24, MOST-OFTEN-NEEDED 1964 RADIO SERVICING INFORMATION

SEARS, ROEBUCK & CO. Chassis 528.54400, Model 4030

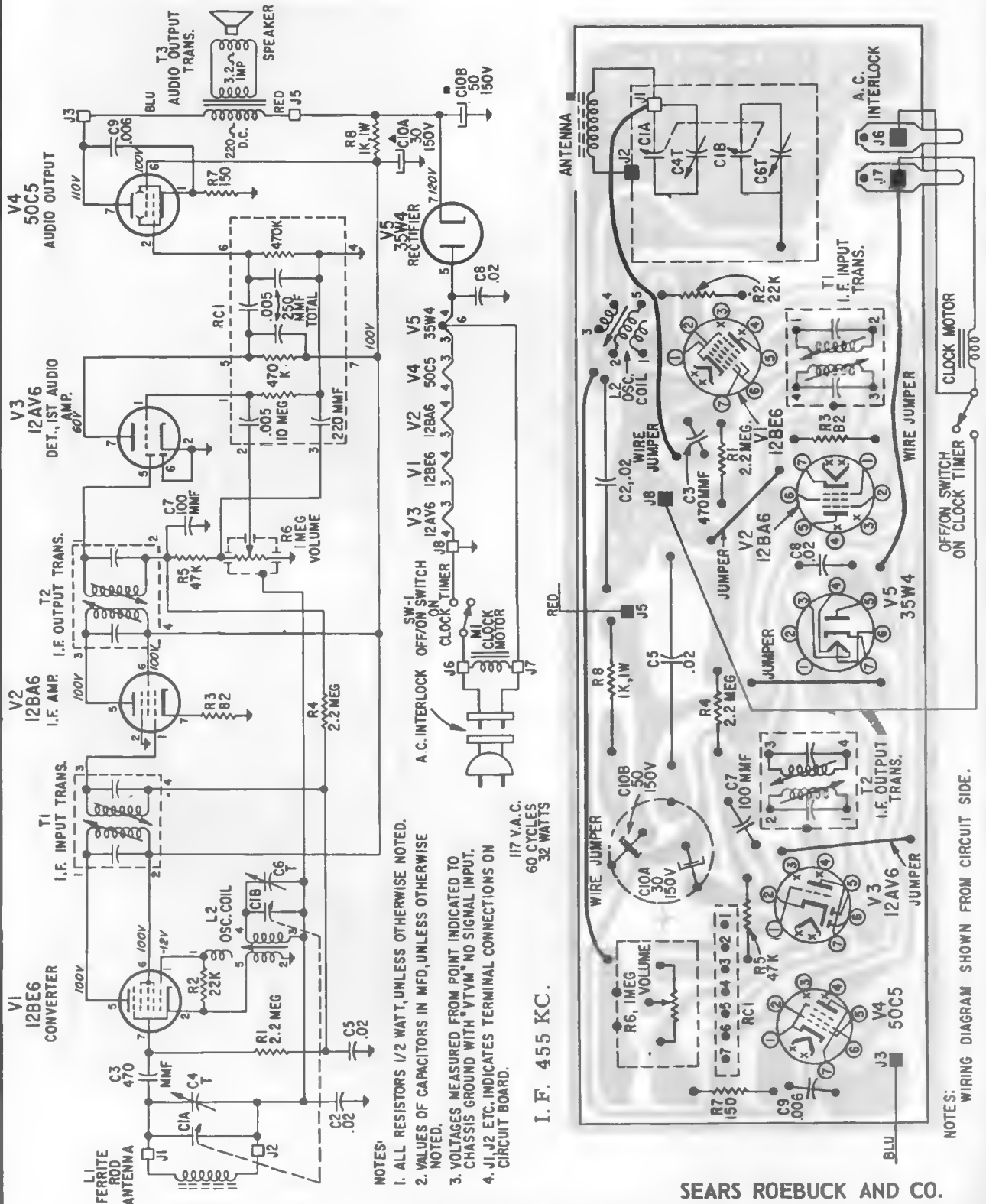

SEARS ROEBUCK AND CO.

SEARS, ROEBUCK & CO. Chassis 528.53500, Models 4032, 4033, 4034

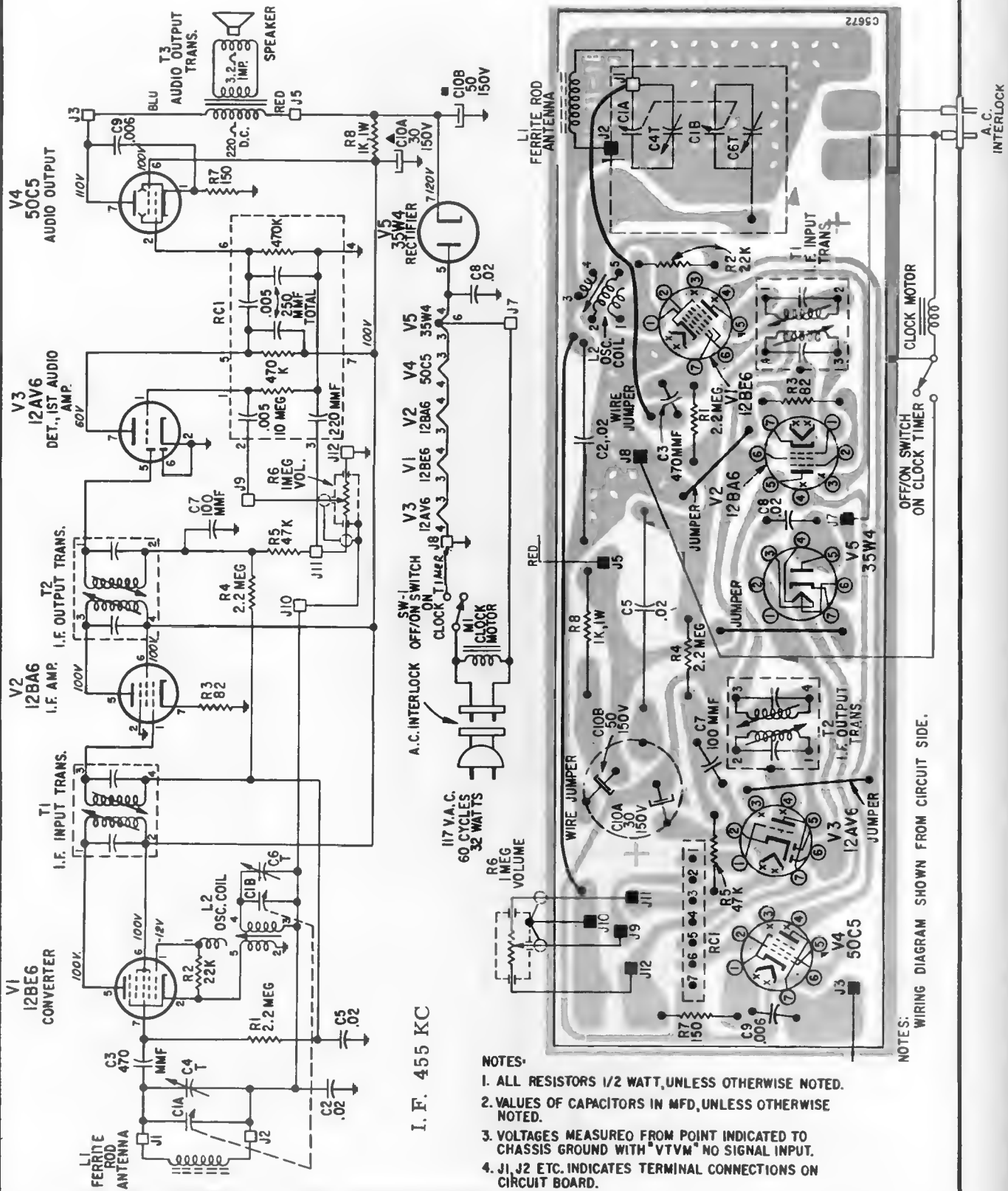

- NOTES:
1. ALL RESISTORS 1/2 WATT, UNLESS OTHERWISE NOTED.
 2. VALUES OF CAPACITORS IN MFD, UNLESS OTHERWISE NOTED.
 3. VOLTAGES MEASURED FROM POINT INDICATED TO CHASSIS GROUND WITH "VTVM" NO SIGNAL INPUT.
 4. J1, J2 ETC. INDICATES TERMINAL CONNECTIONS ON CIRCUIT BOARD.

SEARS, ROEBUCK and CO.

Chassis 528.54670,
Models 4043, 4044

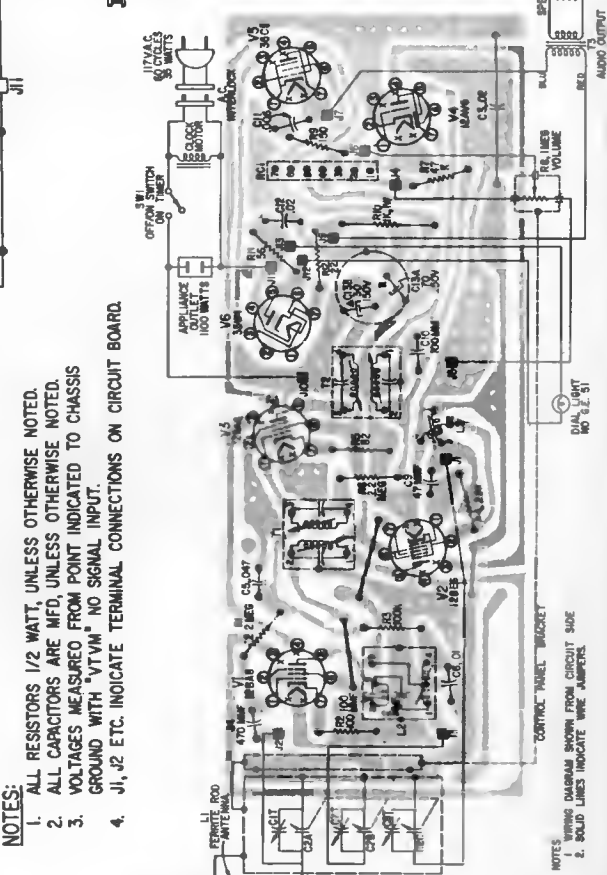
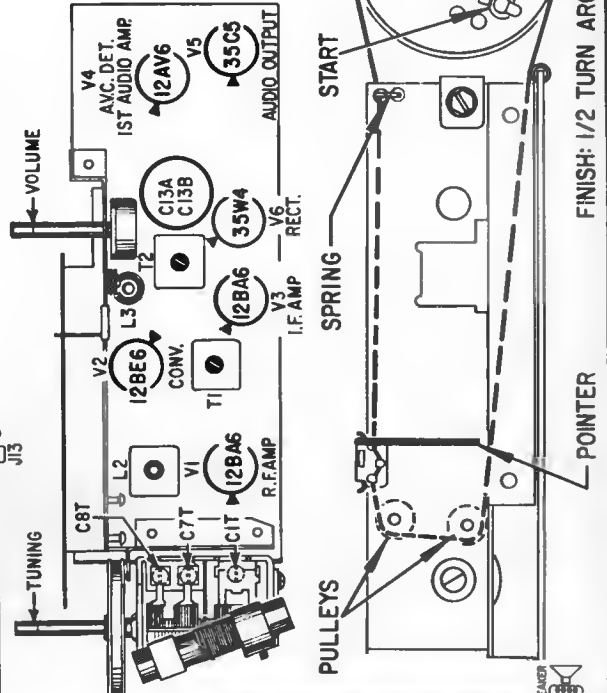
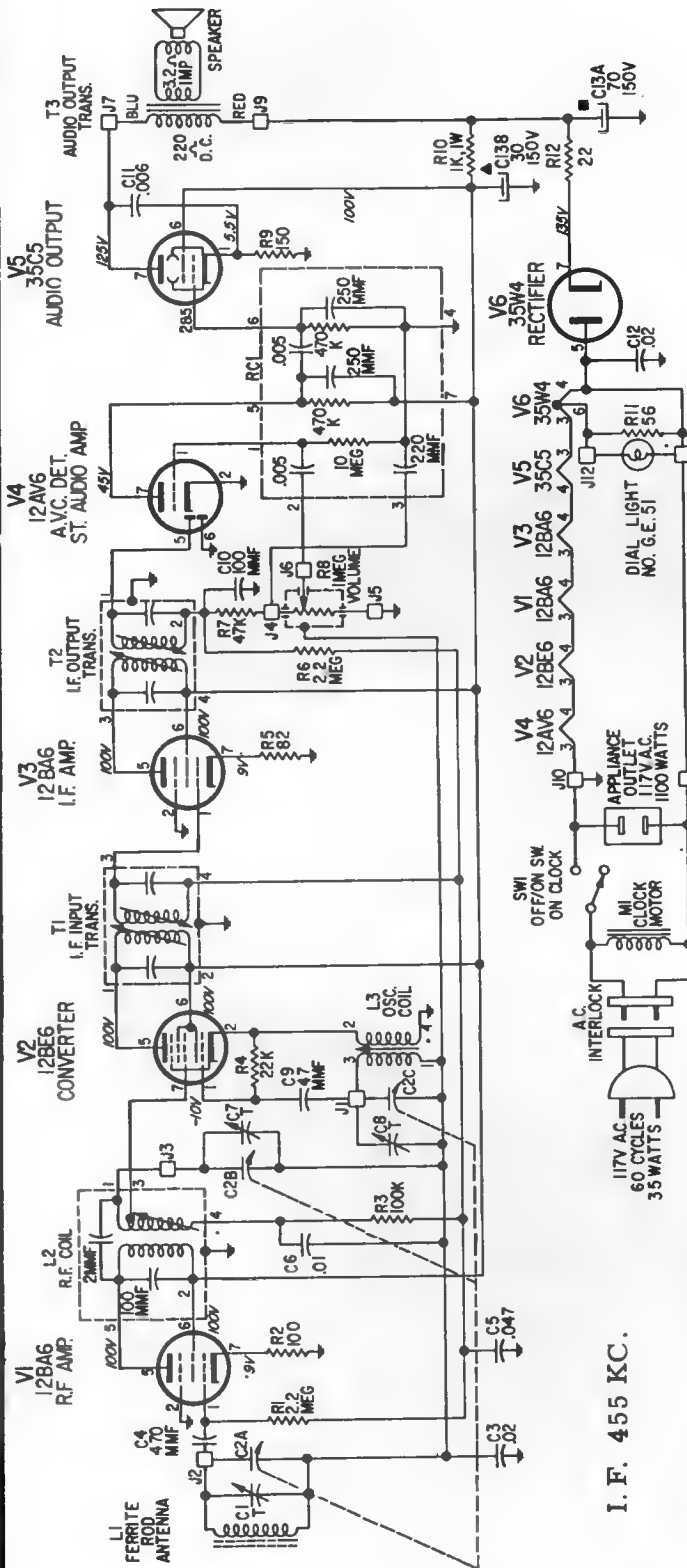

I. F. 455 KC.

- NOTES:
1. ALL RESISTORS 1/2 WATT, UNLESS OTHERWISE NOTED.
 2. ALL CAPACITORS ARE MFD, UNLESS OTHERWISE NOTED.
 3. VOLTAGES MEASURED FROM POINT INDICATED TO CHASSIS GROUND WITH "VTVM" NO SIGNAL INPUT.
 4. J1, J2 ETC. INDICATE TERMINAL CONNECTIONS ON CIRCUIT BOARD.

SEARS, ROEBUCK and CO.

SEARS, ROEBUCK & CO. Chassis 528.54880, Models 4079, 4080, 4081, 4082

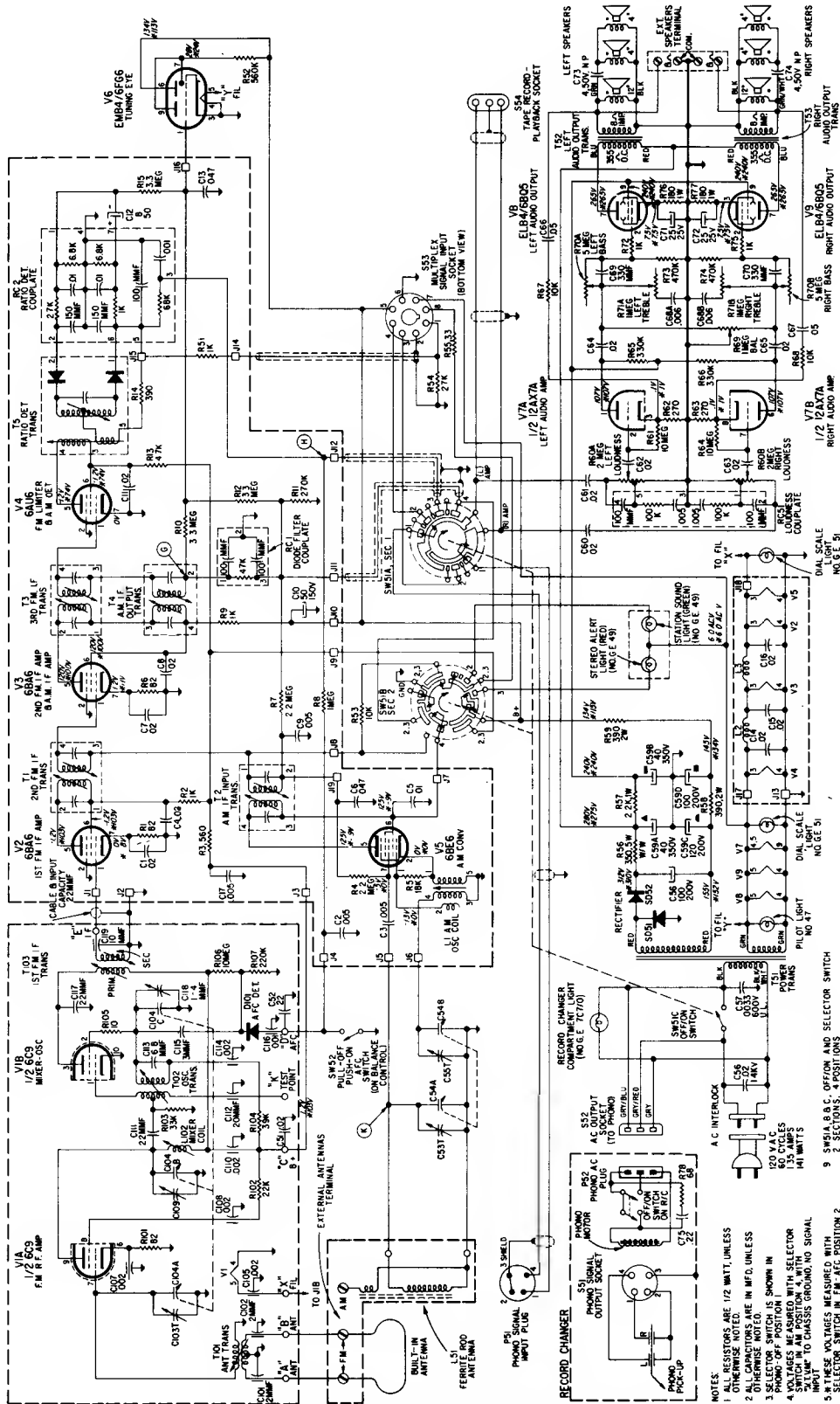

A.M. I.F. 455 KC.
F.M. I.F. 10.7 MC.

SEARS, ROEBUCK & CO. Chassis 528.54880, Models 4079, 4080, 4081, 4082

- NOTES:
1. RESISTORS ARE 1/2 WATT, UNLESS OTHERWISE NOTED.
 2. ALL CAPACITORS ARE IN MICROFARADS UNLESS OTHERWISE NOTED.
 3. PHONO OF POSITION 1 IS SHOWN IN THIS CIRCUIT.
 4. VOLTAGES MEASURED WITH SELECTOR SWITCH IN POSITION 1.
 5. INPUT VOLTAGES MEASURED WITH SELECTOR SWITCH IN POSITION 1.
 6. VOLTAGE TOLERANCE MAY VARY 20%.
 7. J1, J2, ETC. ARE TERMINAL CONNECTION ON CIRCUIT BOARD.
 8. 0000 ON SPEAKERS INDICATES...

SONY TR-727

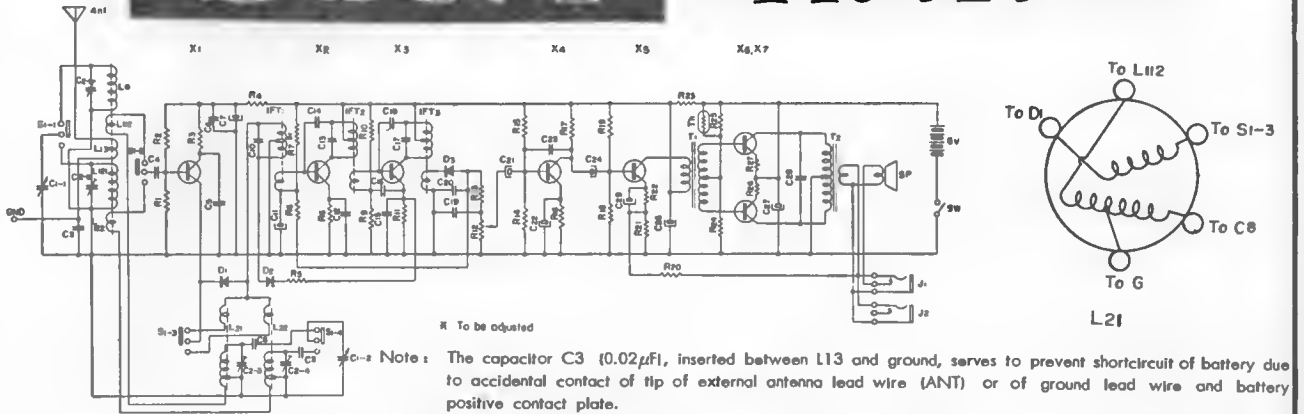

Frequency Coverage: MW 535 Kc—1,605 Kc
SW 3.9 Mc—12 Mc
IF Frequency: 455 Kc

Mounting Diagram for TR-727 —Mounted Side—

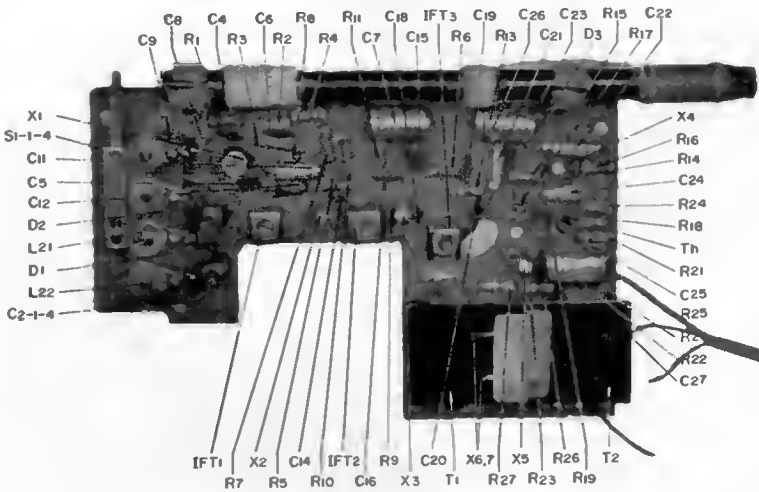

Electronic Parts List for TR-727

Parts No.	Symbol	Description
1-401-118-00	L ₁₁ -L12	Ferrite Bar Antenna
1-405-003-01	L ₂₃	MW, Oscillator Coil
1-405-004-01	L ₂₅	SW, Oscillator Coil
1-513-056-00	S ₁₋₃	Band Setting Switch
1-403-034-00	IFT ₁	IF Transformer
1-403-035-00	IFT ₂	"
1-403-036-00	IFT ₃	"
1-423-043-00	T ₁	Driving Transformer
1-427-061-00	T ₂	Output Transformer
1-507-030-20	SP	Tuning Earphone Jack
1-502-063-00	SP	Speaker 8Ω
	X ₁	Transistor 2SA70
	X ₂	" 2SC769
	X ₃	" 2SC768
	X ₄	" 2SD451
	X ₅	" 2SD450
	X ₆	" 2S8513
	X ₇	" 2S8513
	D ₁	Diodes 1T24G
	D ₂	" 1T23G
	D ₃	Diodes 1T23G
	Th	Thermistor 5-90
1-203-130-00	R ₁	Carbon Resistor
	R ₂	18KΩ RD 1/4L ± 5%
1-203-058-00	R ₃	" 3.3KΩ "
1-203-049-00	R ₄	" 2.2KΩ "
1-203-049-00	R ₅	" 2.2KΩ "
1-203-031-00	R ₆	" 1KΩ "
1-203-065-00	R ₇	" 5.6KΩ "
1-203-583-00	R ₈	" 64KΩ "
1-203-024-00	R ₉	" 470Ω "
1-203-058-00	R ₁₀	" 3.3KΩ "
1-203-129-00	R ₁₁	" 27KΩ "
1-203-024-00	R ₁₂	" 330Ω "
1-221-231-00	R ₁₃	Potentiometer 5KΩ
1-203-024-00	R ₁₄	Carbon Resistor
	R ₁₅	470Ω RD 1/4L ± 5%
1-203-065-00	R ₁₆	" 5.6KΩ "
1-203-130-00	R ₁₇	" 18KΩ "
1-203-031-00	R ₁₈	" 1KΩ "
1-203-058-00	R ₁₉	Carbon Resistor
	R ₂₀	3.3KΩ RD 1/4L ± 5%
1-203-058-00	R ₂₁	" 3.3KΩ "
1-203-045-00	R ₂₂	" 5.6KΩ "
1-203-011-00	R ₂₃	" 100Ω "
1-203-001-00	R ₂₄	" 51Ω "
1-203-018-00	R ₂₅	" 220Ω "
1-203-011-00	R ₂₆	" 100Ω "
1-203-049-00	R ₂₇	" 2.2KΩ "
1-203-011-00	R ₂₈	" 100Ω "
1-203-584-00	R ₂₉	" 3Ω "
1-203-584-00	R ₃₀	" 3Ω "
1-151-057-00	C ₁	Tuning Capacitor 2 Gang
1-141-109-00	C ₂	Trimmer Capacitor 4 Unit
1-101-073-00	C ₃	Ceramic Capacitor 0.02μf ± 10%
1-101-072-00	C ₄	" 0.01μf "
1-101-098-00	C ₅	" 0.005μf "
1-101-072-00	C ₆	" 0.01μf "
1-119-010	C ₇	Electrolytic Capacitor 100μf 6V
1-103-044	C ₈	Shyal Capacitor 370pf ± 5%
1-103-038	C ₉	Shyal Capacitor 3000pf ± 5%
1-119-001	C ₁₀	180pf built in IFT ₁
1-101-073-00	C ₁₁	Electrolytic Capacitor 10μf 3V
1-101-073-00	C ₁₂	Ceramic Capacitor 0.02μf ± 10%
1-101-073-00	C ₁₃	180pf built in IFT ₂
1-101-044-00	C ₁₄	" 2pf ± 0.5pf "
1-101-073-00	C ₁₅	" 0.02μf ± 10% "
1-101-073-00	C ₁₆	" 0.02μf "
1-101-044-00	C ₁₇	180pf built in IFT ₃
1-101-073-00	C ₁₈	" 2pf ± 0.5pf "
1-101-075-00	C ₁₉	" 0.02μf ± 10% "
1-119-001	C ₂₀	Electrolytic Capacitor 10μf 3V
1-119-007	C ₂₁	" 30μf 3V
1-101-098-00	C ₂₂	Ceramic Capacitor 0.005μf ± 10%
1-119-001	C ₂₃	Electrolytic Capacitor 10μf 3V
1-119-007	C ₂₄	" 30μf 3V
1-119-010	C ₂₅	" 100μf 6V
1-119-010	C ₂₆	" 100μf 6V
1-105-097-00	C ₂₇	Mylar Capacitor 0.3μf

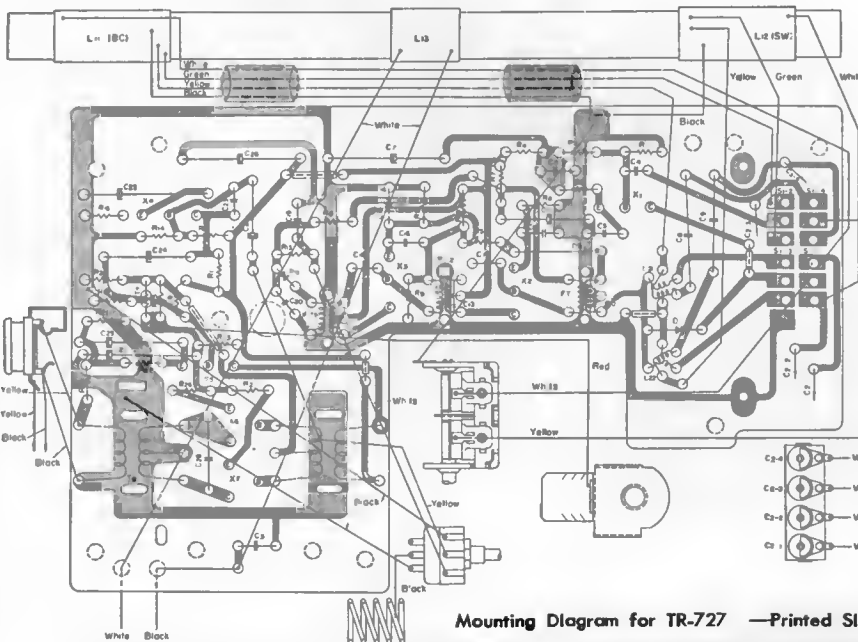

SONY

TR-730

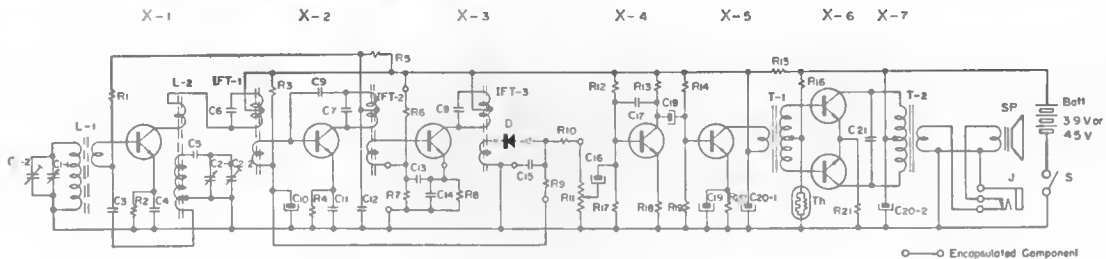

Frequency Coverage : 535 Kc ~ 1,605 Kc
IF Frequency : 455 Kc
Current Drain : 9 mA at zero signal, 42 mA at 92 mW output
Dimensions : 3" x 2-1/4" x 1-1/8" (76 x 57 x 29 mm)
Weight : Less than 7 ounces (180 gr.) with Battery

To take out Circuit Board :

- 1) Remove one gold-plated Philips screw (plus screw) on the left side.
- 2) Unscrew the rear cover securing screw.
- 3) Open the rear cover.
- 4) Remove securing metal post for rear cover.
- 5) Remove one Philips screw (plus screw) on the chassis near volume knob.

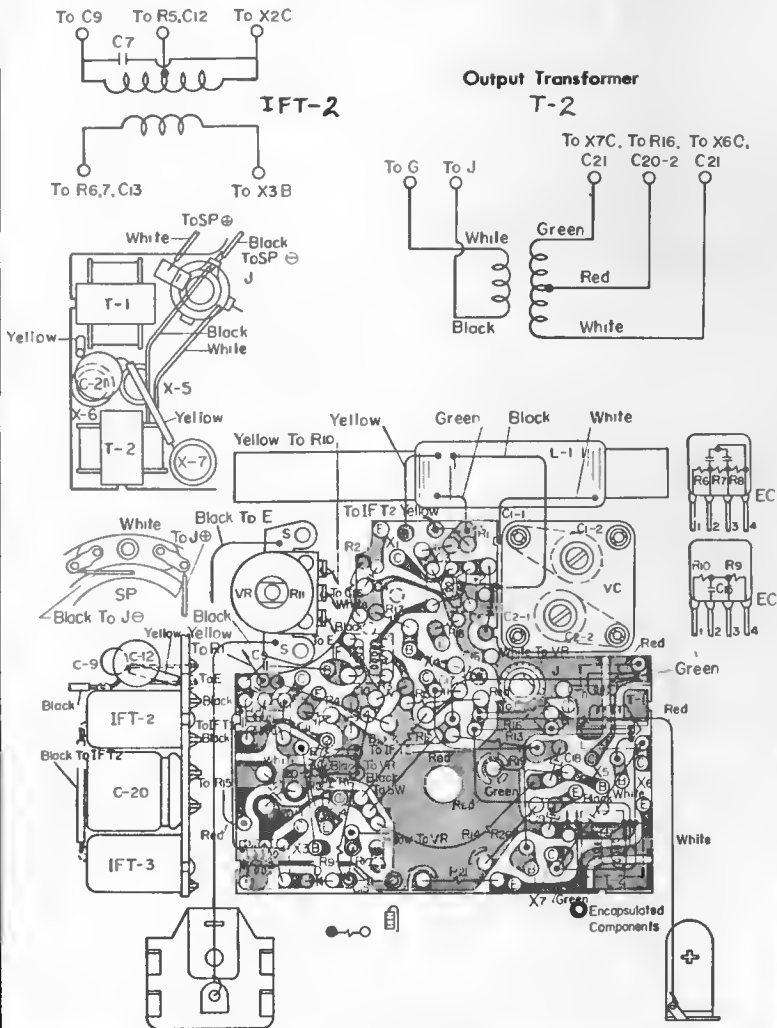

Parts No.	Symbol	Description
1-401-108-01	L ₁	Ferrite Bar Antenna
1-405-001-	L ₂	Oscillator Coil
1-403-057-00	IFT ₁	IF Transformer
1-403-058-00	IFT ₂	"
1-403-059-00	IFT ₃	"
1-423-042-	T ₁	Driving Transformer
1-427-059-	T ₂	Output "
1-502-044	Sp	Speaker
1-507-038-01	J	Earphone Jack
	X ₁	Transistor 2SC73
	X ₂	" 2SC75
	X ₃	" 2SC76
	X ₄	" 2SD65
	X ₅	" "
	X ₆	" "
	X ₇	" "
	D	Diode 1T23G
	Th	Thermistor CS120
	Batt.	Battery
	R ₁	Composition Resistor 10 kΩ 1/10 W ± 10%
	R ₂	15 kΩ "
	R ₃	75 kΩ 1/10 W ± 5%
	R ₄	330 Ω 1/10 W ± 10%
	R ₅	5.6 kΩ "
	R ₆	Encapsulated Components 22 kΩ
	R ₇	" " 3.3 kΩ
	R ₈	" " 330 kΩ
	R ₉	" " 10 kΩ
	R ₁₀	" " 330 Ω
	R ₁₁	Potentiometer 5 kΩ
	R ₁₂	Composition Resistor 56 kΩ 1/10 W ± 10%
	R ₁₃	2.2 kΩ "
	R ₁₄	27 kΩ "
	R ₁₅	Composition Resistor 100 Ω 1/10 W ± 10%
	R ₁₆	" 2.7 kΩ "
	R ₁₇	" 3.3 kΩ "
	R ₁₈	" 33 Ω "
	R ₁₉	" 2.2 kΩ "
	R ₂₀	" 62 Ω "
	R ₂₁	" 5.1 Ω "
	C ₃	Capacitor 0.01 μF +80%/-20% Ceramic
	C ₄	" 0.005 μF " "
	C ₅	" 130 pF ± 50% Styral
	C ₆	" 150 pF built in IFT ₁
	C ₇	" 150 pF built in IFT ₂
	C ₈	" 150 pF built in IFT ₃
	C ₉	" 1 pF 0.5 pF Ceramic
	C ₁₀	" 5 μF ± 10% 3 V Electrolytic
	C ₁₁	" 0.02 μF +80%/-20% Ceramic
	C ₁₂	" 0.01 μF " "
	C ₁₃	0.01 μF (Encapsulated with R ₆ , 7, 8)
	C ₁₄	0.01 μF (Encapsulated with R ₉ , 10)
	C ₁₅	"
	C ₁₆	Capacitor 0.3 μF +100%/-20% 6 V Alox
	C ₁₇	0.02 μF +100%/-20% Ceramic
	C ₁₈	5 μF ± 10% 3 V Electrolytic
	C ₁₉	5 μF +100%/-20% "
	C ₂₀	50 μF x 2 ± 10% 4.5V Electrolytic Block
	C ₂₁	0.01 μF +80%/-20% Ceramic

SONY TR-7170

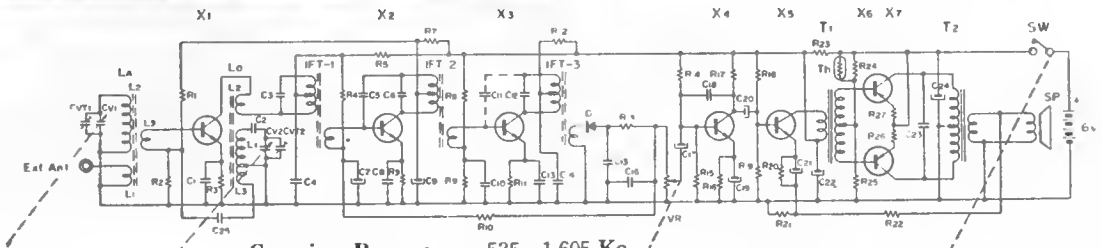

Covering Range: 535—1,605 Kc
IF Frequency: 455 Kc

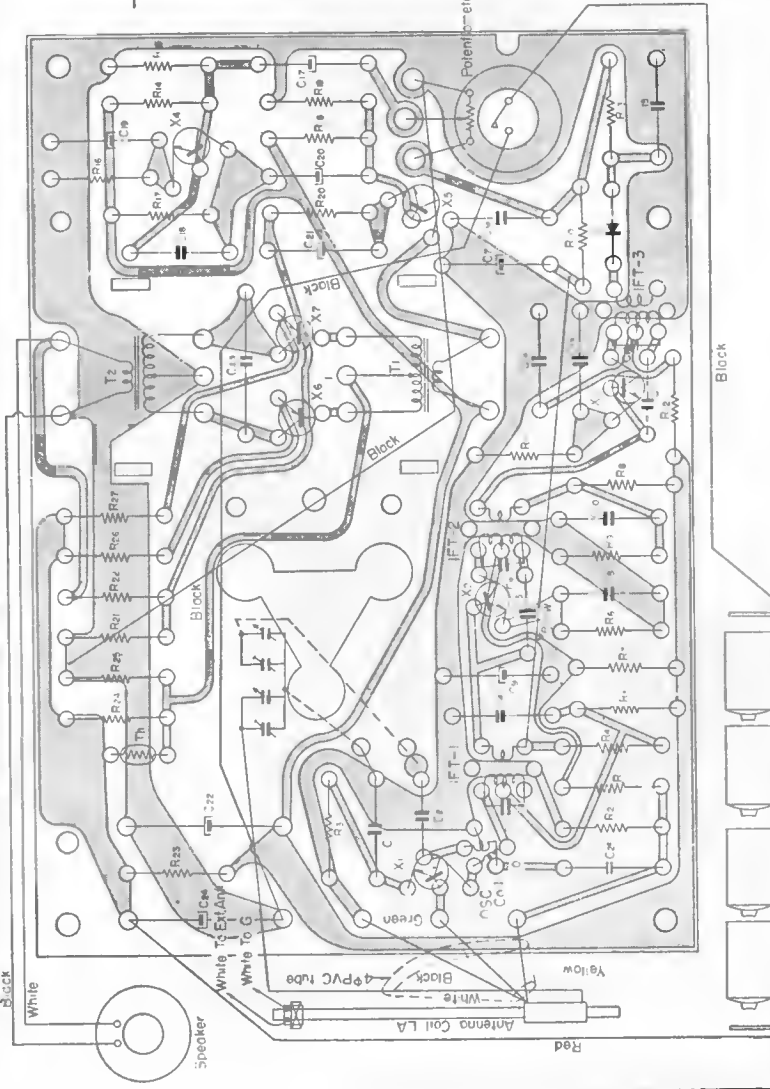
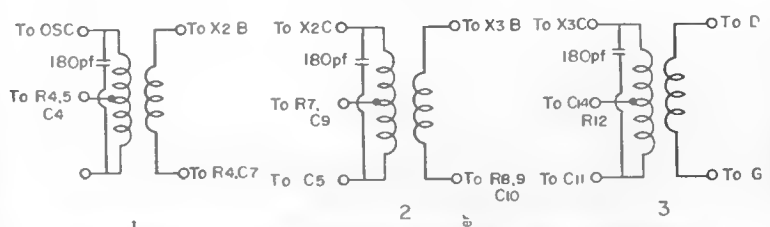

Mounting Diagram (Printed Side)

Symbol	Description
LA	Ferrite Bar Antenna
Lo	Oscillator Coil
IFT-1	IF transformer
VR	Potentiometer
X ₁	Transistor 2SC 73
X ₂	2SC 76
X ₃	2SC 76
X ₄	2SD 65
X ₅	2SD 65
X ₆	2SB 51
X ₇	2SB 51
D	Diode 1T 23
Th	Thermistor S-90
R ₁	Carbon Resistor 12 KΩ 1/2 W ± 10%
R ₂	150 KΩ " "
R ₃	8.2 KΩ " "
R ₄	47 KΩ " "
R ₅	1.0 KΩ " "
R ₆	470 Ω " "
R ₇	6.8 KΩ " "
R ₈	12 KΩ " "
R ₉	2.2 KΩ " "
R ₁₀	5.6 KΩ " "
R ₁₁	470 Ω " "
R ₁₂	470 Ω " "
R ₁₃	1.0 KΩ " "
R ₁₄	5.6 KΩ " "
R ₁₅	2.2 KΩ " "
R ₁₆	470 Ω " "
R ₁₇	Carbon Resistor 1.0 KΩ
R ₁₈	5.6 KΩ " "
R ₁₉	3.3 KΩ " "
R ₂₀	220 Ω " "
R ₂₁	10 Ω " "
R ₂₂	100 Ω " "
R ₂₃	220 Ω " "
R ₂₄	100 Ω " "
R ₂₅	2.2 KΩ " "
R ₂₆	3 Ω " "
R ₂₇	3 Ω " "
C ₁	Capacitor 0.005 μF Electrolytic
C ₂	370 pF Styrol
C ₃	180 pF built in IFT
C ₄	0.05 μF Electrolytic
C ₅	2 pF Styrol
C ₆	180 pF built in IFT
C ₇	10 μF 6 V Electrolytic
C ₈	0.05 μF " "
C ₉	10 μF " "
C ₁₀	0.05 μF " "
C ₁₁	—deleted—
C ₁₂	Capacitor 180 pF built in IFT
C ₁₃	0.05 μF Electrolytic
C ₁₄	0.05 μF " "
C ₁₅	0.02 μF " "
C ₁₆	0.01 μF " "
C ₁₇	10 μF 6 V " "
C ₁₈	0.005 μF " "
C ₁₉	30 μF 3 V " "
C ₂₀	10 μF 6 V " "
C ₂₁	30 μF 3 V " "
C ₂₂	100 μF 6 V " "
C ₂₃	0.3 μF (0.25) " "
C ₂₄	100 μF 6 V " "
C ₂₅	0.01 μF " "

SYLVANIA

Chassis 405-1, Model 45P20

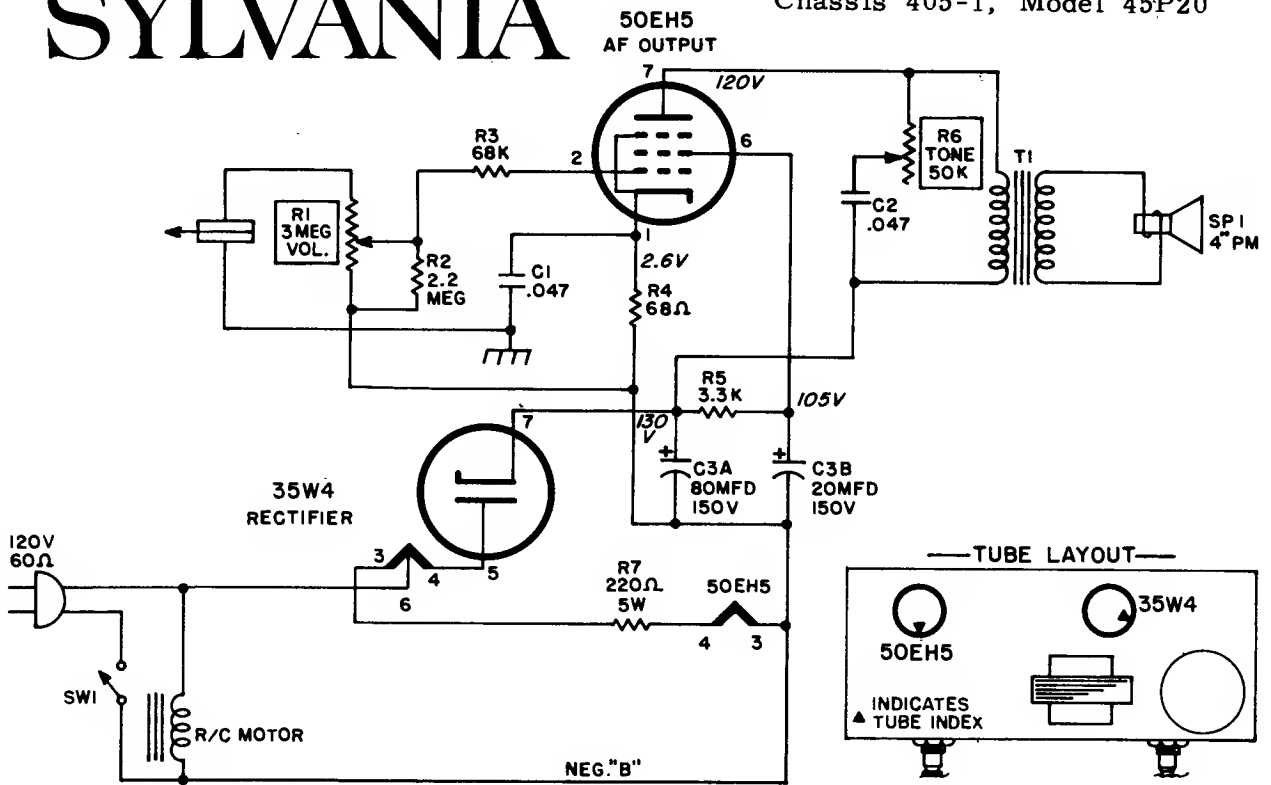

SYLVANIA Chassis 406-1, Model 45P32

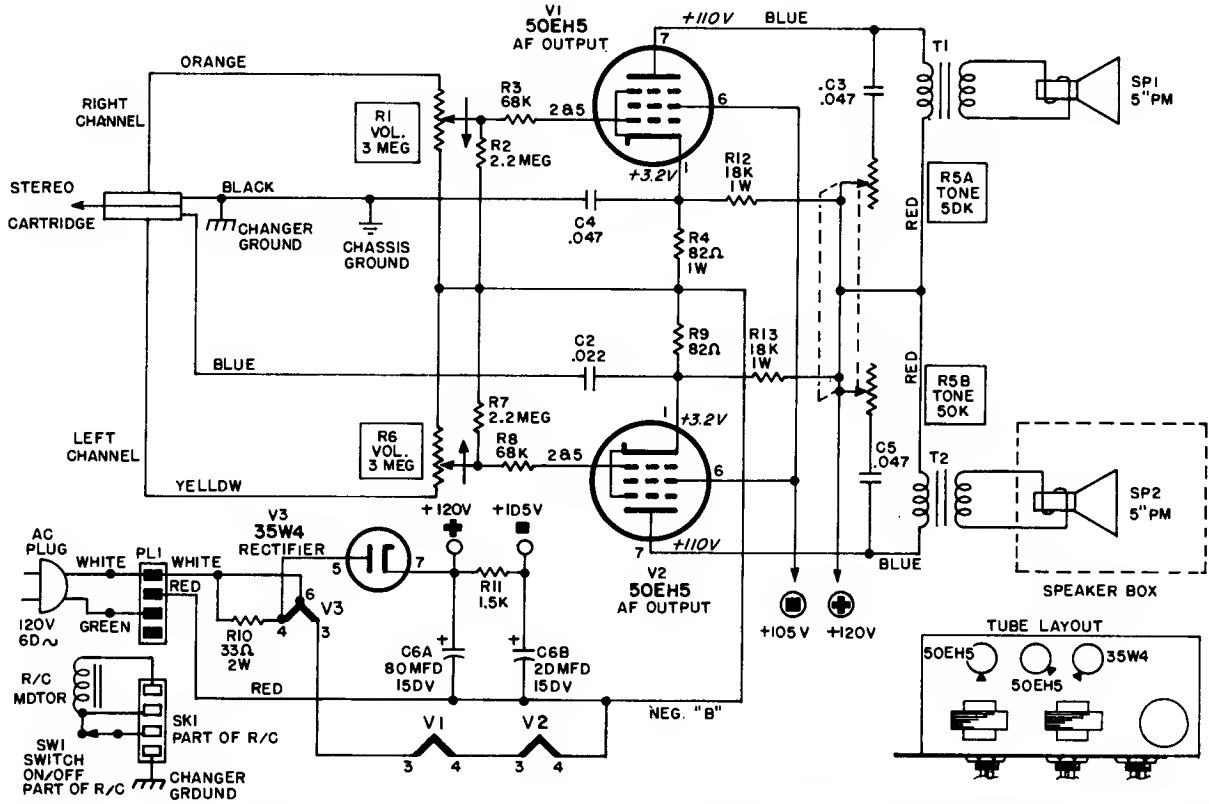

VOLUME R-24, MOST-OFTEN-NEEDED 1964 RADIO SERVICING INFORMATION

SYLVANIA Chassis 702-2, Models SC26 Series, Alignment Information, Continued
 (Alignment continued on the next page, other data preceding and following)

— AM ALIGNMENT —
(Selector switch in AM position)

STEP	TUNING CAPACITOR SETTING	TEST EQUIPMENT HOOK-UP	GENERATOR FREQUENCY	ADJUSTMENT POINT	ADJUST FOR
1	Fully Open	SIGNAL GENERATOR - "Hot" lead thru a .1 Mfd Capacitor to test point (A) . Ground lead to chassis. AC VOLTMETER - Across Speaker terminals of channel set at maximum volume.	455 KC	T5 Bottom T5 Top T4 Bottom T4 Top	Maximum Meter Reading
2	Fully Open	Same as Step 1	1620 KC	C29D AM Osc. Trimmer	Maximum Meter Reading
3	1400	SIGNAL GENERATOR - Radiate signal to receiver through a lobb consisting of several turns of wire. AC VOLTMETER - Same as Step 1.	Set generator to a frequency corresponding to receiver dial (until signal is heard through receiver speaker.)	C29B AM Ant. Trimmer	Maximum Meter Reading

— FM ALIGNMENT —
(Selector switch in FM position)

STEP	TUNING CAPACITOR SETTING	TEST EQUIPMENT HOOK-UP	GENERATOR FREQUENCY	ADJUSTMENT POINT	ADJUST FOR
1	Point of non-interference	SIGNAL GENERATOR - "Hot" lead through a .005 Mfd capacitor to test point (B) . Ground lead to chassis. AC VOLTMETER - "Hot" lead to test point (C) . Ground lead to chassis.	10.7 MC	T3 Bottom T2 Bottom T2 Top T1 Top L5	Maximum Meter Reading
2	Same as Step 1	SIGNAL GENERATOR - Same as Step 1. AC VOLTMETER - "Hot" lead to test point (D) . Ground lead connected to chassis.	10.7 MC	T3 Top	Zero Meter Reading
3	108	SIGNAL GENERATOR - Same as Step 1. AC VOLTMETER - Same as Step 1.	108 MC	C2D FM Osc. Trimmer	Maximum Meter Reading

VOLUME R-24, MOST-OFTEN-NEEDED 1964 RADIO SERVICING INFORMATION
 SYLVANIA Chassis 702-2, Models SC26 Series, Alignment Information, Continued

— FM ALIGNMENT (Continued) —

4	88	SIGNAL GENERATOR - Same as Step 1. AC VOLTMETER - Same as Step 1.	88 MC	C2B FM Ant. Trimmer	Maximum Meter Reading
---	----	--	-------	---------------------	-----------------------

— MULTIPLEX ALIGNMENT PROCEDURE —

Outlined below is an alternate method of FM MULTIPLEX ALIGNMENT using a standard Multiplex Broadcast as the signal source. Whenever FM multiplex alignment equipment is used, follow the procedures specified

by the equipment manufacturer. Peaking of the 19KC and 38KC coils is easily accomplished, however correct phase relationship is absolutely essential for maximum channel separation.

(Selector switch in FM multiplex position)

STEP	TEST EQUIPMENT HOOK-UP	SIGNAL USED	ADJUSTMENT POINT	ADJUST FOR
1	OSCILLOSCOPE - Hot lead to pin 6 of 19EA8. Ground lead to chassis.	Multiplex	T6	Max output of the 19 KC pilot carrier
2	OSCILLOSCOPE - Hot lead to pin 1 of 6C4. Ground lead to chassis	Multiplex	T7	Max output of the 38 KC signal
3	Remove test equipment			
4	Very carefully readjust T6 and T7 for maximum separation of sound. NOTE: Some multiplex stations transmit announcements on one channel only. Adjust T6 or T7 for minimum output on opposite channel being transmitted.			

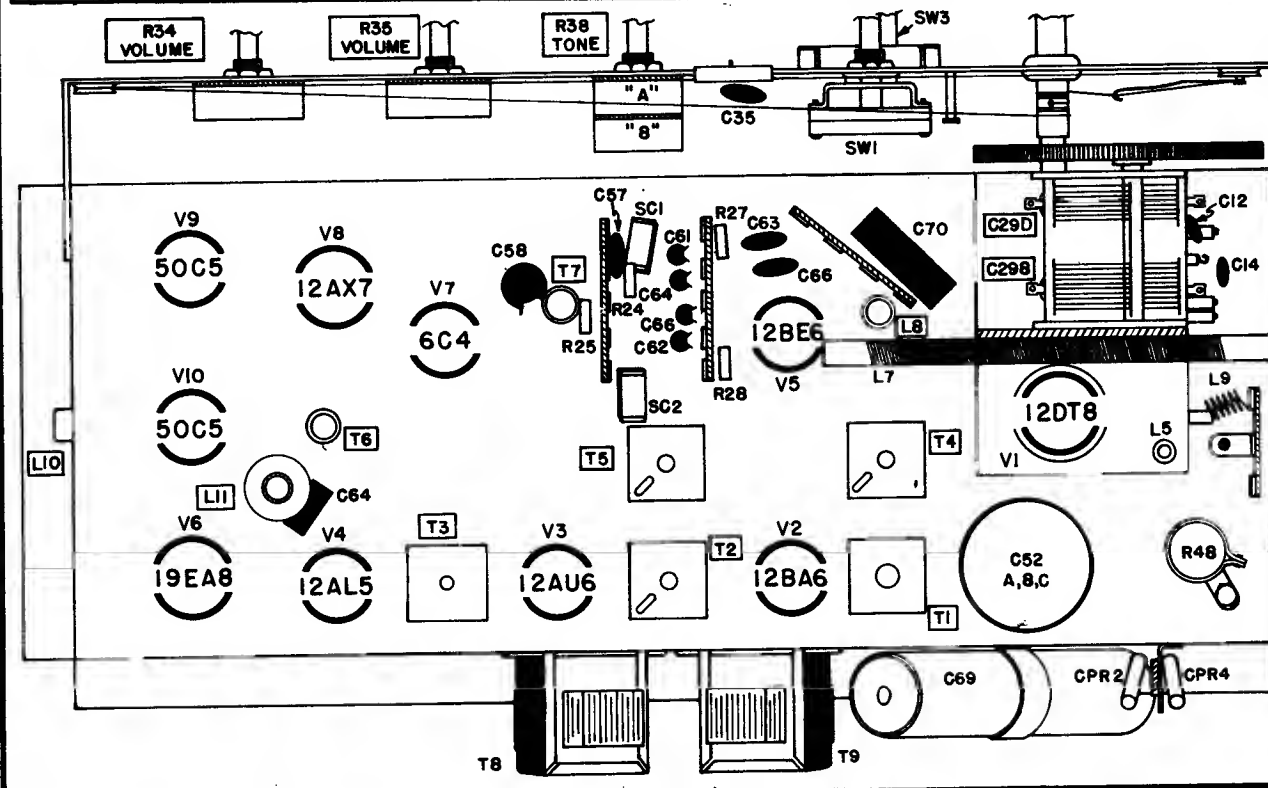

SYLVANIA Chassis 407-1, Models 45P34, 45P35 Series

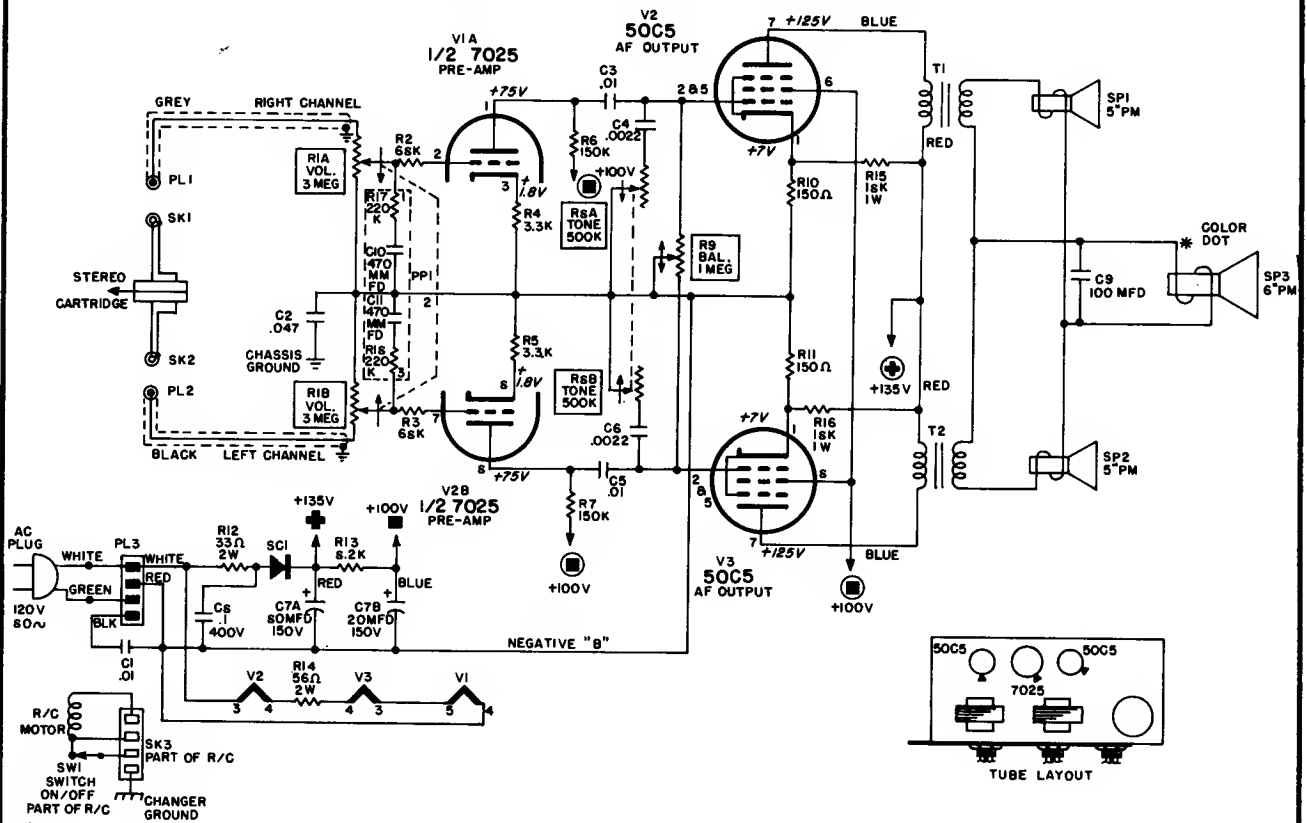

SYLVANIA Chassis 702-2, Models of SC26 Series, Service data continued

CHASSIS REMOVAL

1. Remove screws securing backcover. Remove backcover.
2. Identify and disconnect leads to speakers and record changer.
3. Remove two (2) screws securing interlock to cabinet.
4. Remove screws securing antenna terminal board to cabinet.
5. Remove knobs by pulling straight up.
6. While supporting chassis remove the five (5) screws and two (2) nuts securing chassis to cabinet.
7. To replace chassis reverse the above procedure.

DIAL CORD

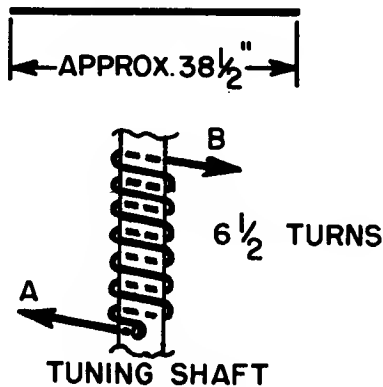

POINTER

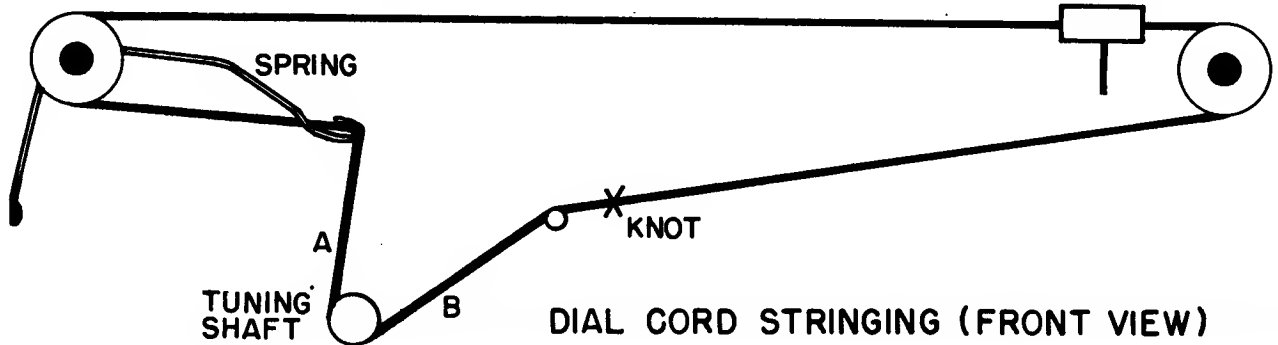



MODELS 7TP-30, 7TP-403Y

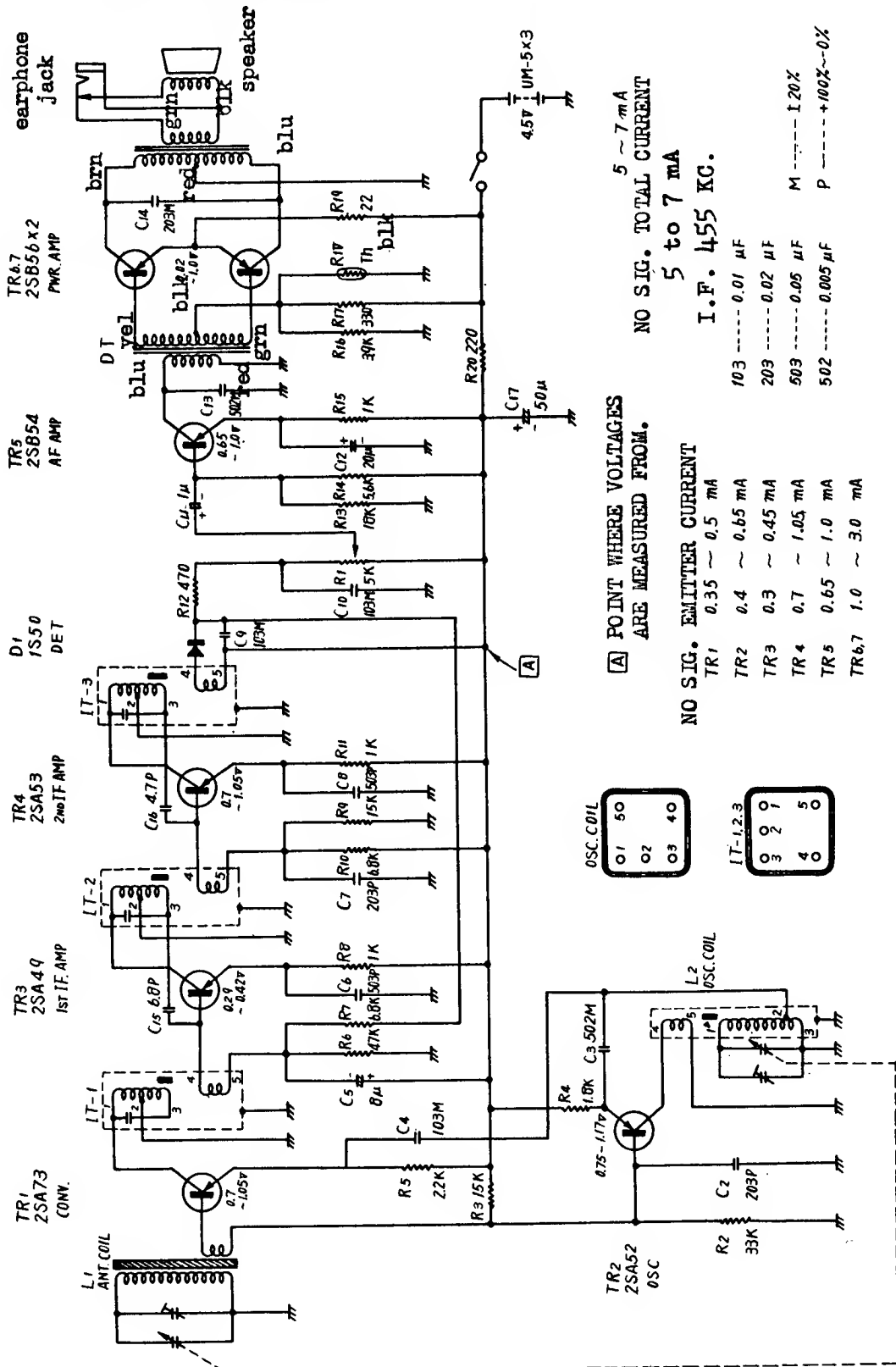

[A] POINT WHERE VOLTAGES ARE MEASURED FROM.

NO SIG. EMITTER CURRENT

TR1	0.35	~ 0.5	mA
TR2	0.4	~ 0.65	mA
TR3	0.3	~ 0.45	mA
TR4	0.7	~ 1.05	mA
TR5	0.65	~ 1.0	mA
TR6,7	1.0	~ 3.0	mA

NO SIG. TOTAL CURRENT

I.F. 455 KC.

103	-----	0.01	μF
203	-----	0.02	μF
503	-----	0.05	μF
502	-----	0.005	μF

5 ~ 7 mA
5 to 7 mA

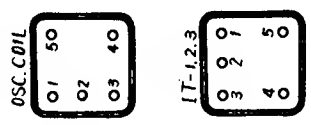

TOSHIBA Models 7TP-30, 7TP-403Y

WEBCOR

DIAGRAM FOR MODEL 1354

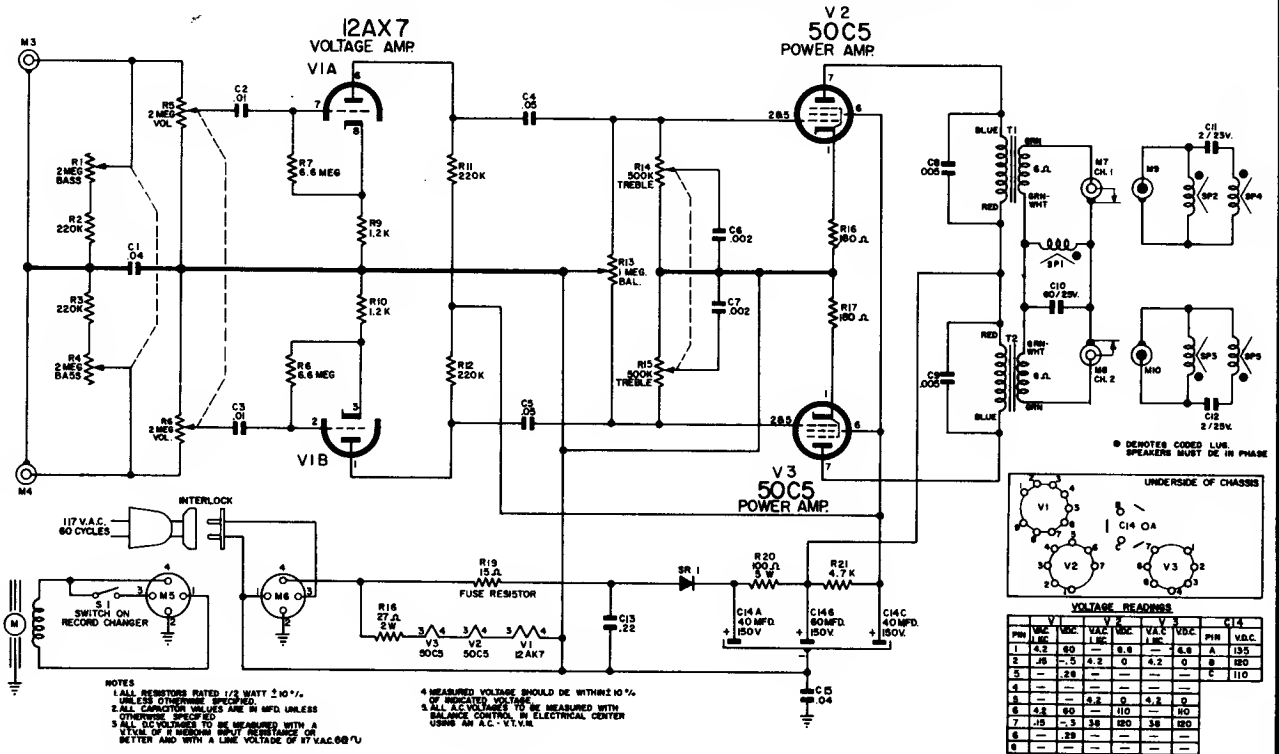

WEBCOR MODEL 1153

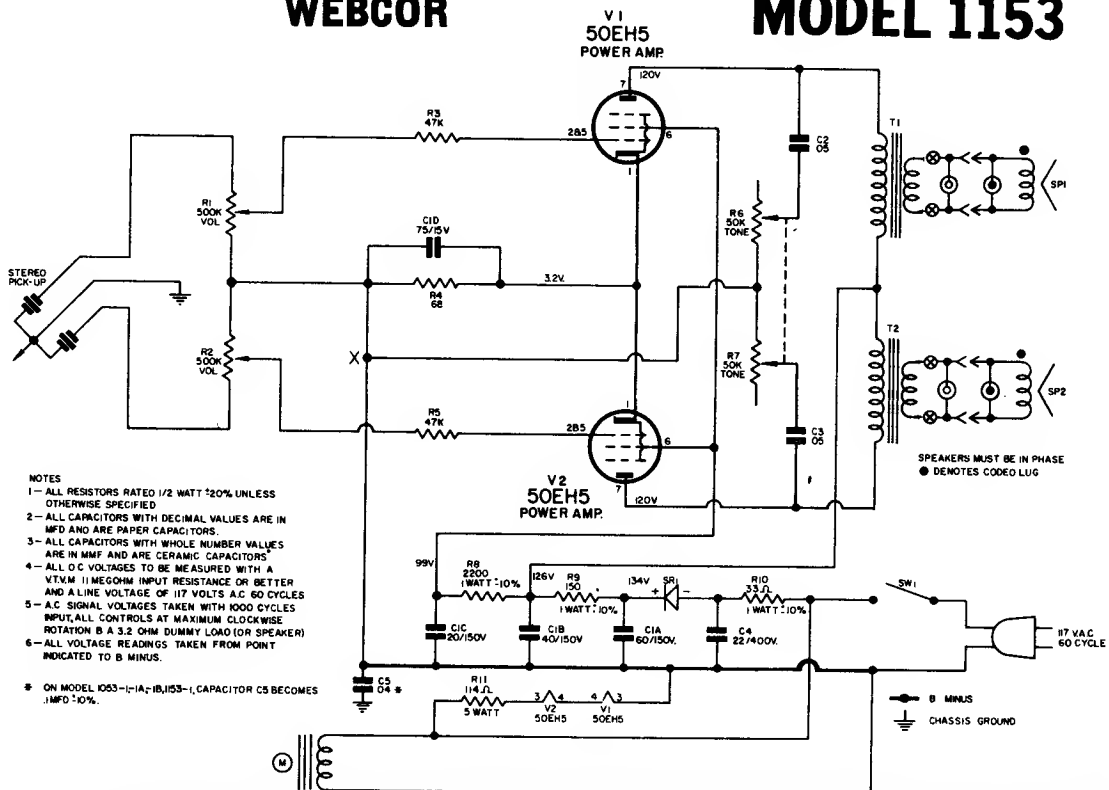

W E B C O R

MODEL 1353 AND 1356

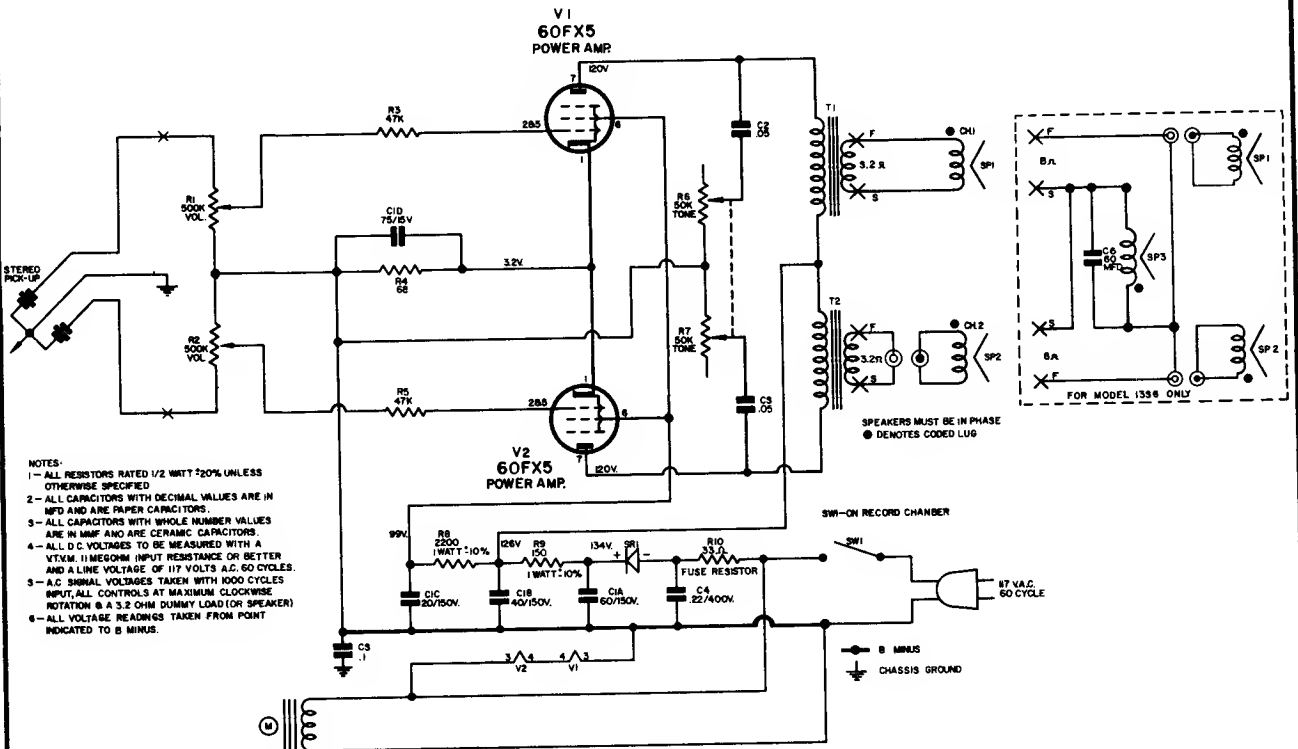

W E B C O R

MODEL 1450

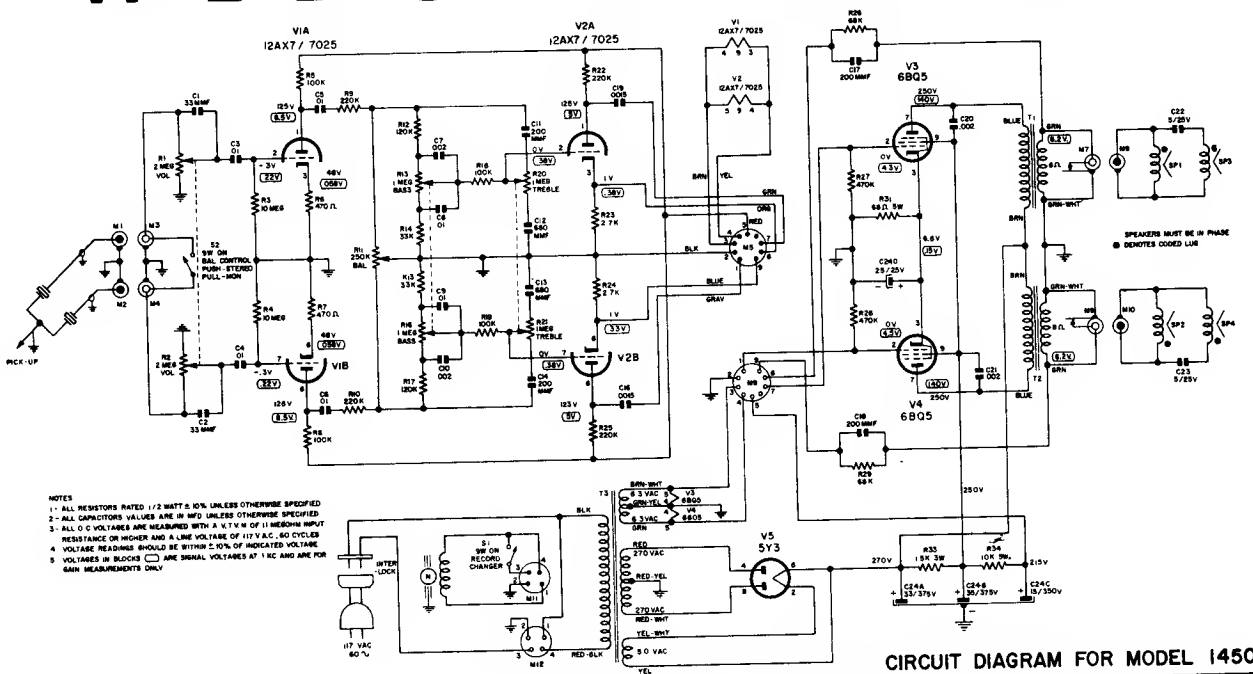

Westinghouse

MODELS
H-846P8GP
H-846P8GPM

CHASSIS
V-2426-3
V-2426-3M

Frequency Range 540 to 1600 KC
 Intermediate Frequency 455 KC

NOTES:

1. DURING SERVICING, BATTERY TERMINALS SHOULD BE METERED, WITH NO SIGNAL & VOL. CONT. AT MINIMUM CURRENT. POINTS AT POINT SHOWN SHOULD BE 14 MA APPROX.
 2. MEASUREMENTS MADE WITH A 470 OHM FROM POINTS INDICATED TO GROUND WITH TUNING CAPACITOR AT MAX. VOLUME CONTROL AT MIN (NO SIGNAL INPUT) BATTERY SOURCE AT 6 VOLTS.
 3. ALL CAPACITANCE VALUES LESS THAN 1 ARE IN μF & VALUES GREATER THAN 1 ARE IN PF. ALL RESISTANCE VALUES ARE IN OHMS 1/2 WATT UNLESS OTHERWISE INDICATED.
- * ON 540 KC IN EARLY PRODUCTION
 * 5M, 10V IN LATE PRODUCTION

FUNCTION	TYPE	PART NO.	TRANS. NO.	ALT. TYPE NO.
TR 1 OSC	6XP6	201038800	11.564	201038801
TR 2 MIXER	6X4	201038801	11.564	201038802
TR 3 1ST IF AMP	6X4	201038802	11.564	201038803
TR 4 2ND IF AMP	6X4	201038803	11.564	201038804
TR 5 AUDIO AMP	6X4	201038804	11.564	201038805
TR 6 AUDIO DRIVER	6X4	201038805	11.564	201038806
TR 7 AUDIO DRIVER	6X4	201038806	11.564	201038807
TR 8 AUDIO OUTPUT	6X4	201038807	11.564	201038808
TR 9 MATCHED PAIR	6X4	201038808	11.564	201038809

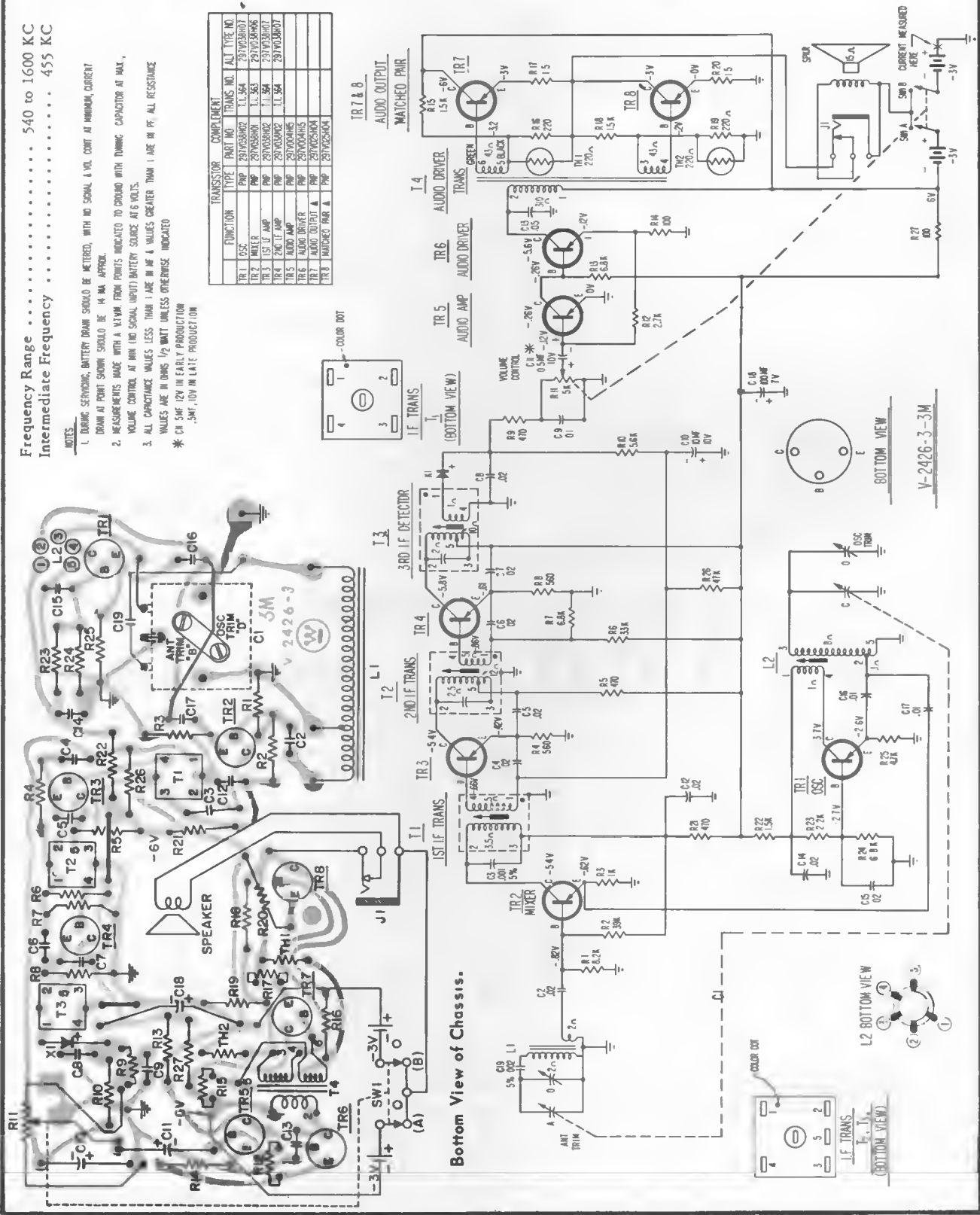

Bottom View of Chassis.

L2 BOTTOM VIEW

V-2426-3-3M

WESTINGHOUSE ELECTRIC

MODELS

ED-1 (Blonde)

ED-2 (Brunette)

TALKING DOLL

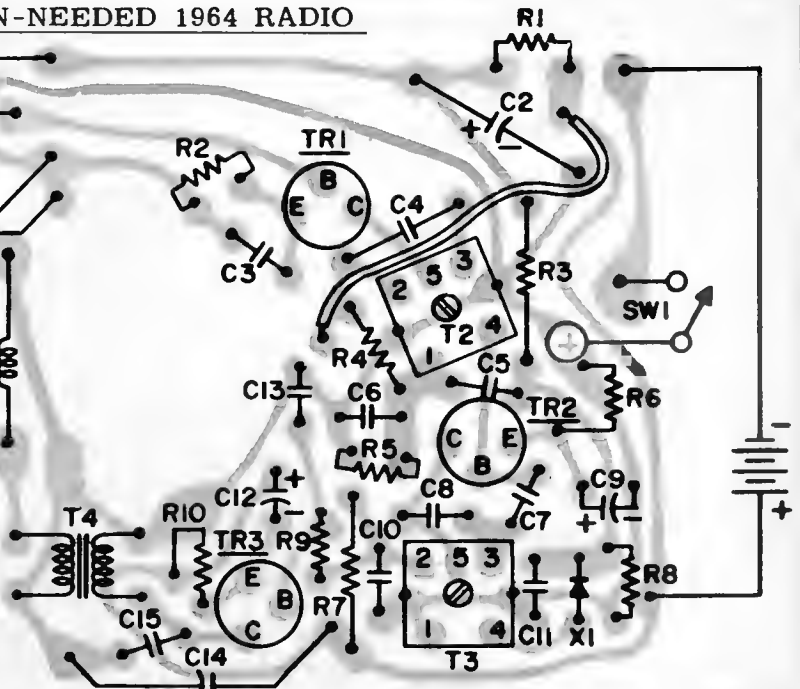

Bottom View of Doll's PC Board With Top Components Shown in Solid Outline.

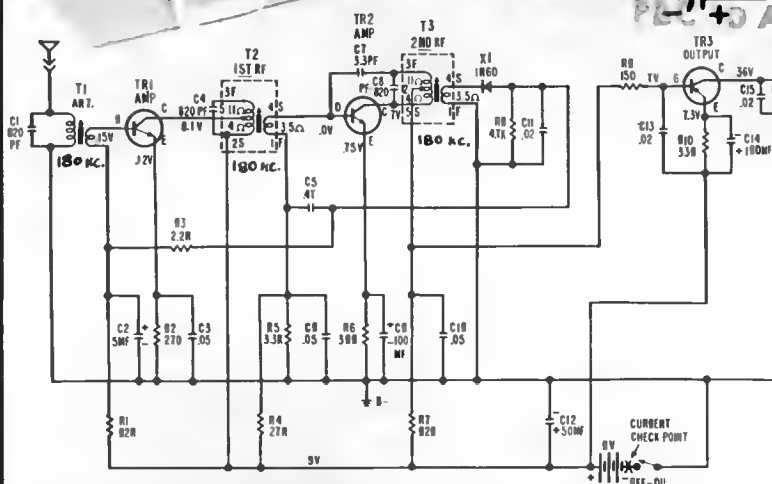

Schematic of Doll's Receiver

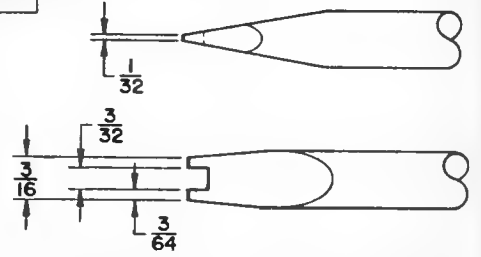

Special tool used for Motorboard Screw Removal. Should be made from a 3/16" screwdriver.

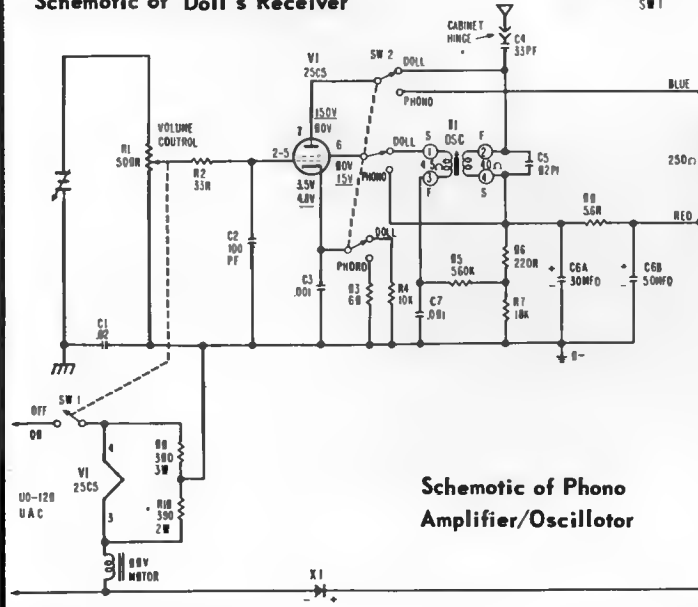

Schematic of Phono Amplifier/Oscillator

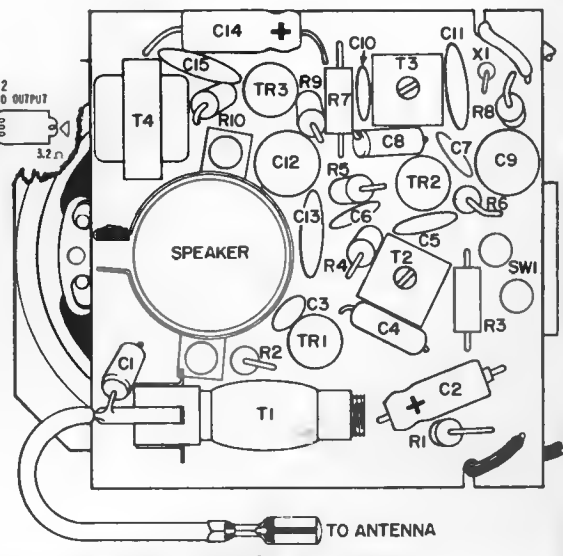

Top View of Doll's PC Board.

VOLUME R-24, MOST-OFTEN-NEEDED 1964 RADIO SERVICING INFORMATION

WESTINGHOUSE Chassis V-2428-3 and -4, used in Models H-850N6, H-851N6, H-852N6, H-855LN6, H-856LN6, H-871N6, H-872N6, H-873N6, H-875LN6, H-876LN6, H-877LN6.

(Continued on next page)

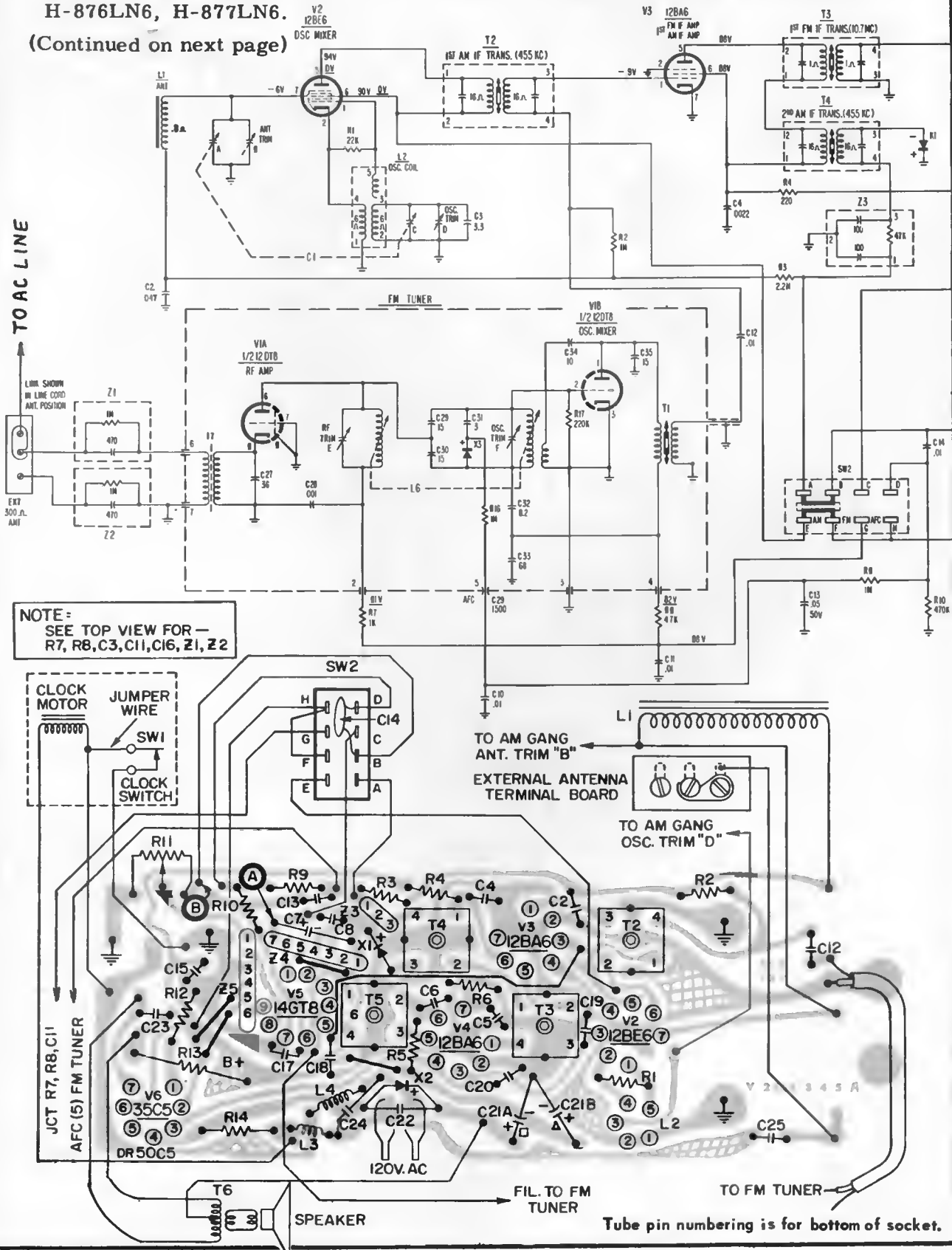

Tube pin numbering is for bottom of socket.

Bottom view of PC board showing location of top components in solid outlines.

VOLUME R-24, MOST-OFTEN-NEEDED 1964 RADIO SERVICING INFORMATION

WESTINGHOUSE Chassis V-2428-3 and -4, used in Models H-850N6, H-851N6, H-852N6, H-855LN6, H-856LN6, H-871N6, H-872N6, H-873N6, H-875LN6, H-876LN6, H-877LN6.

(Continued from preceding page, at right)

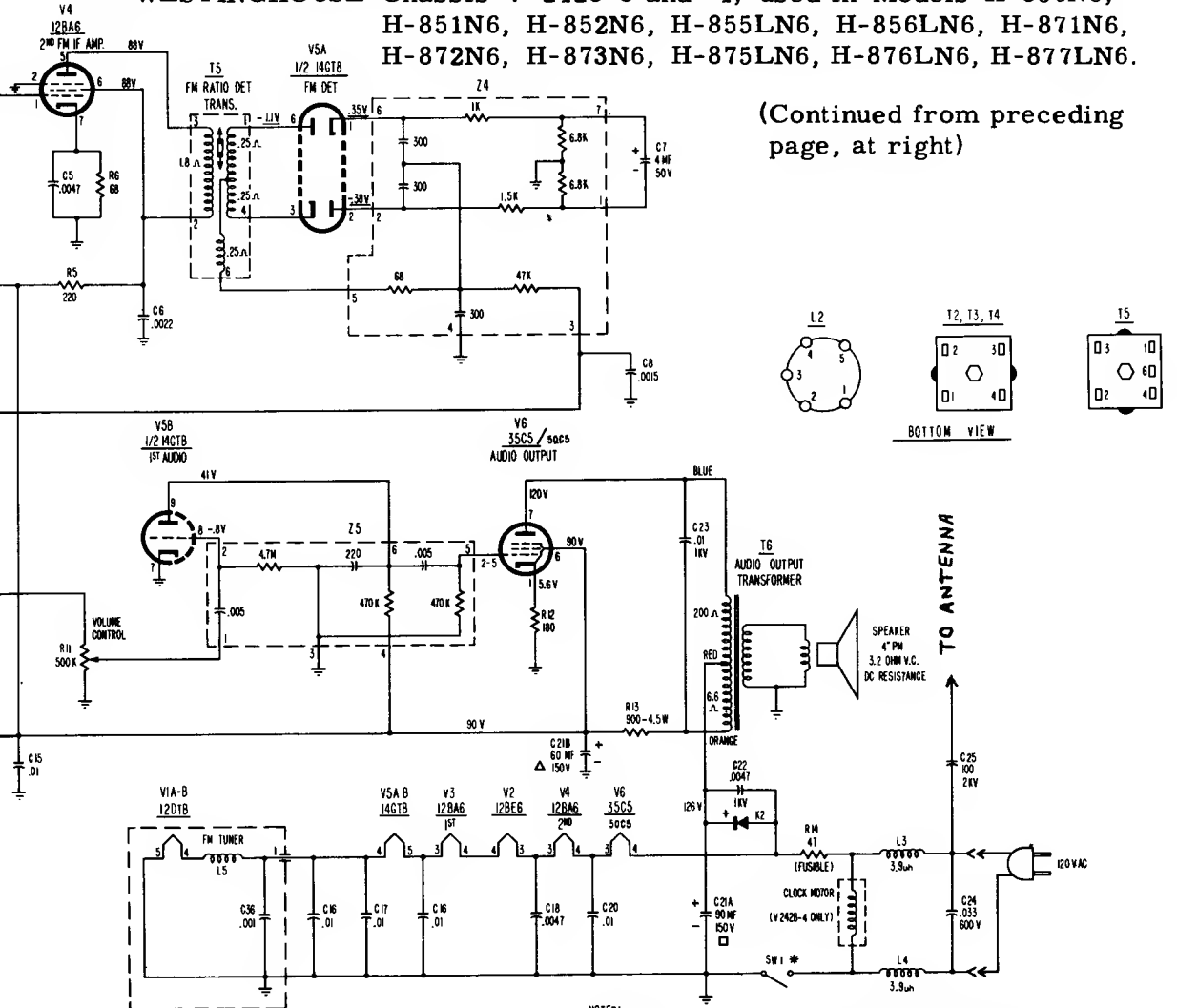

NOTES:

1. ALL CAPACITANCE VALUES LESS THAN 1(ONE) ARE IN PF AND VALUES GREATER THAN 1(ONE) ARE IN PF (PICOFARAD). ALL RESISTANCE VALUES ARE IN OHMS 1/2 UNLT UNLESS OTHERWISE INDICATED.
 2. VOLTAGES TAKEN WITH A VTVM FROM POINTS INDICATED TO B-, TUNING CAPACITOR AT MAXIMUM, VOLUME CONTROL AT MINIMUM, LINE VOLTAGE AT 120V AC NO SIGNAL INPUT. SW 2 IN AM POSITION.
- UNDERLINED VOLTAGES SW 2 IN FM POSITION.
 * SW 1 IS PART OF VOLUME CONTROL CHASSIS V 2428-3
 SW 1 IS PART OF CLOCK CHASSIS V 2428-4

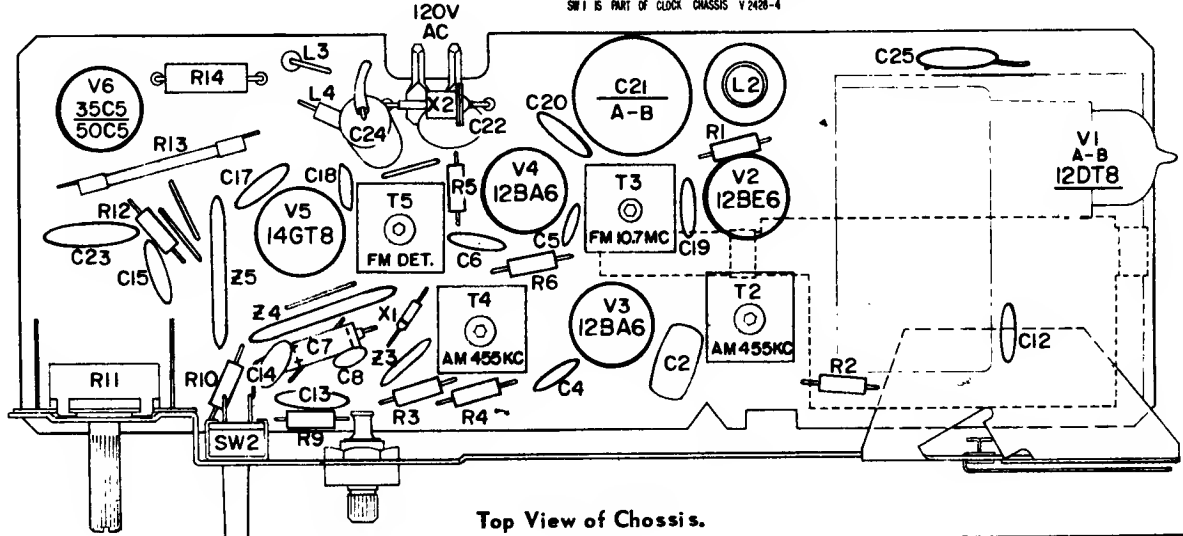

Top View of Chassis.

Westinghouse

CHASSIS V-2450-1
 MODELS H-880T5, H-881T5

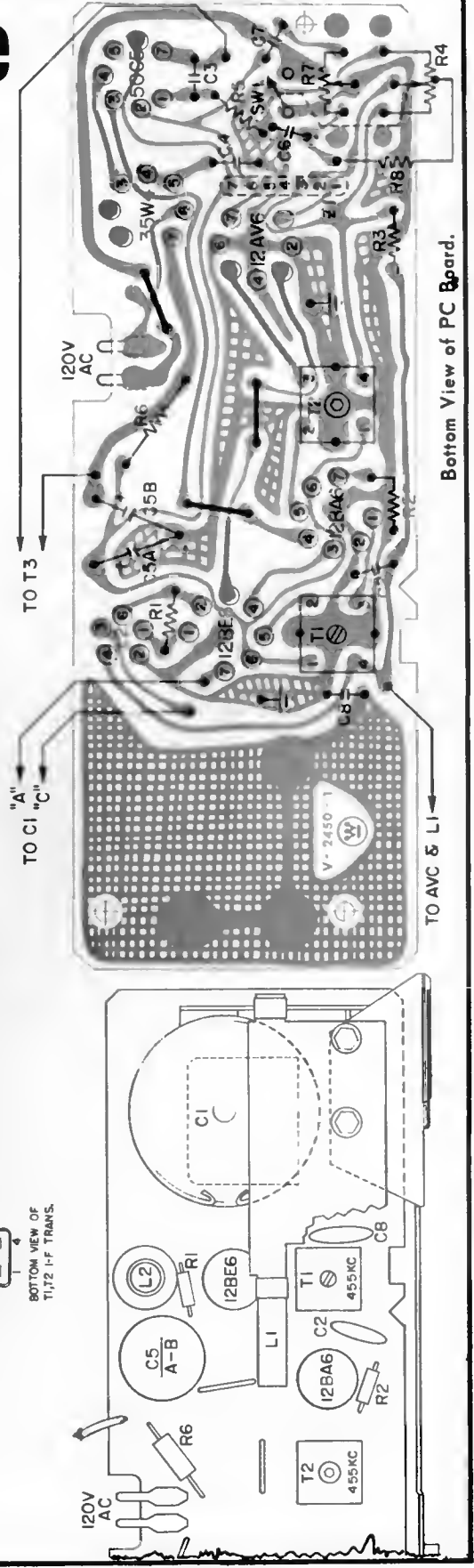
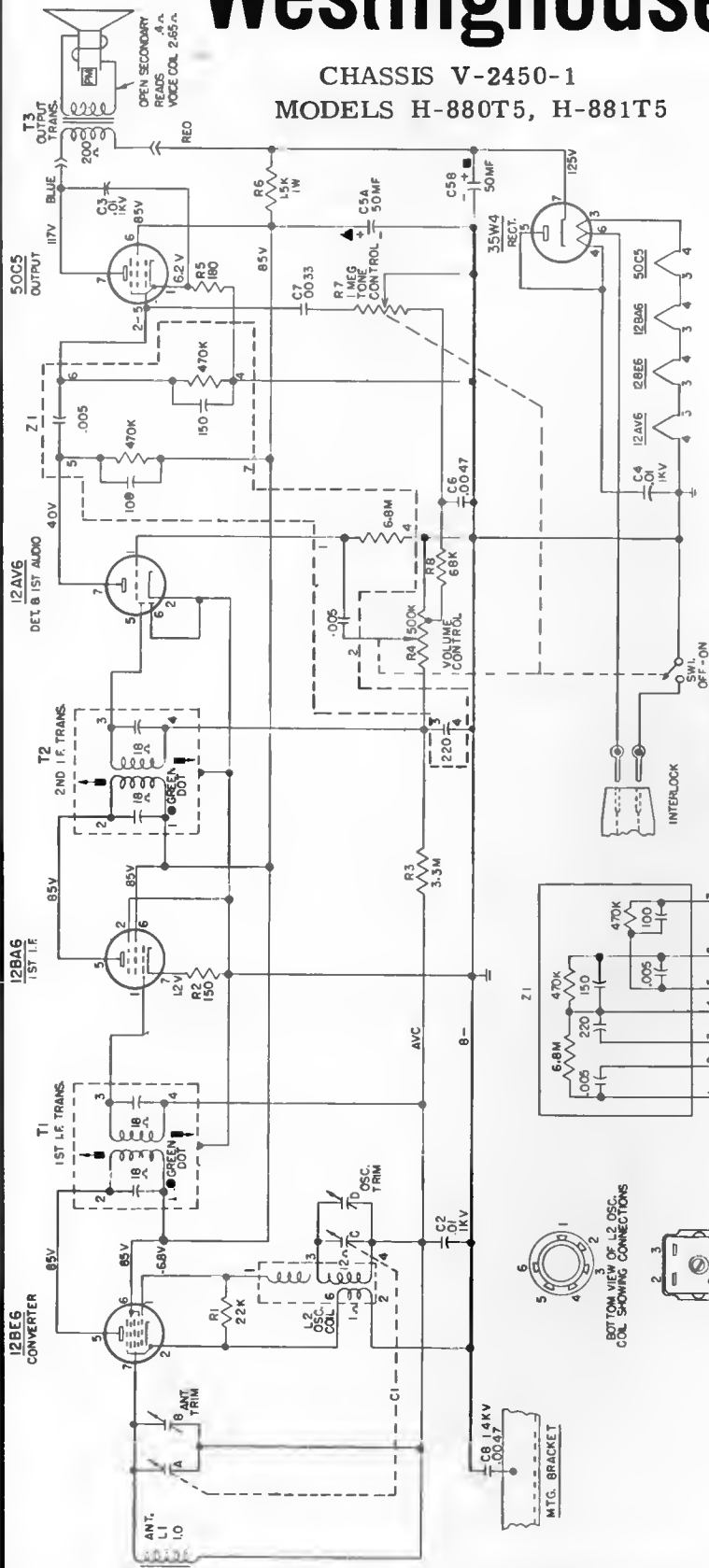

Bottom View of PC Board.

VOLUME R-24, MOST-OFTEN-NEEDED 1964 RADIO SERVICING INFORMATION

WESTINGHOUSE Chassis V-2507-7, Model H-69ACS1A

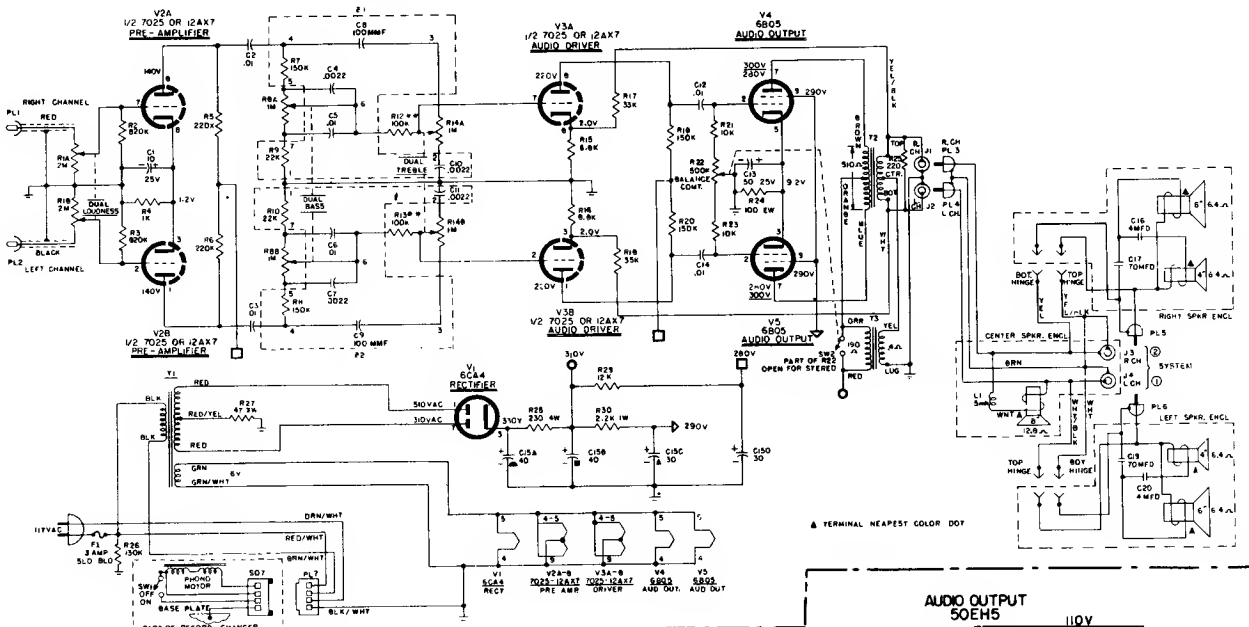

- NOTES:
1. ALL CAPACITANCE VALUES IN MFD & ALL RESISTANCE VALUES IN OHMS UNLESS OTHERWISE STATED.
 2. ALL VOLTAGES MEASURED FROM CHASSIS GROUND USING A V.T.V.M. NO SIGNAL INPUT. LINE VOLTAGE SET AT 117 V.A.C. READINGS SHOULD BE AS SHOWN $\pm 20\%$.
 3. REAR SECTIONS OF ALL CONTROLS ARE THE RIGHT CHANNEL.
 4. ALL AMPULF CONNECTORS VIEWED FROM CONTACT END.
 5. R & B & H IS ARE NOT INCLUDED IN R1 OR R2.
 6. VOLTAGES UNDERLINED WITH SW 2 IN MONAURAL POSITION.
 7. FUSE F1 IN LATER PRODUCTION ONLY.

Models H-62MPS1A, H-62MPS2A, H-62MPS3A, Chassis V-2508-2

- NOTES:
1. ALL CAPACITANCE VALUES IN MFD AND ALL RESISTANCE VALUES IN OHMS UNLESS OTHERWISE STATED.
 2. ALL VOLTAGES MEASURED FROM 0- USING A V.T.V.M. LINE VOLTAGE SET AT 117 V.A.C. READINGS SHOULD BE AS SHOWN $\pm 20\%$.
 3. CHASSIS GROUND COMMON B-

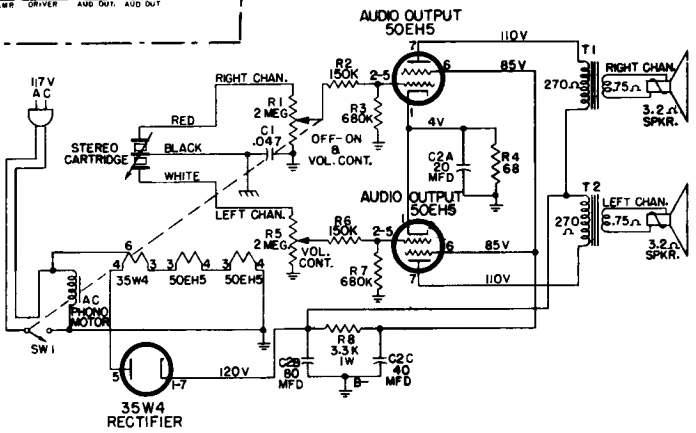

Chassis V-2508-5, Models H-75AC1A, H-75AC2A

Chassis V-2508-14, Models H-96AC1, H-96AC2

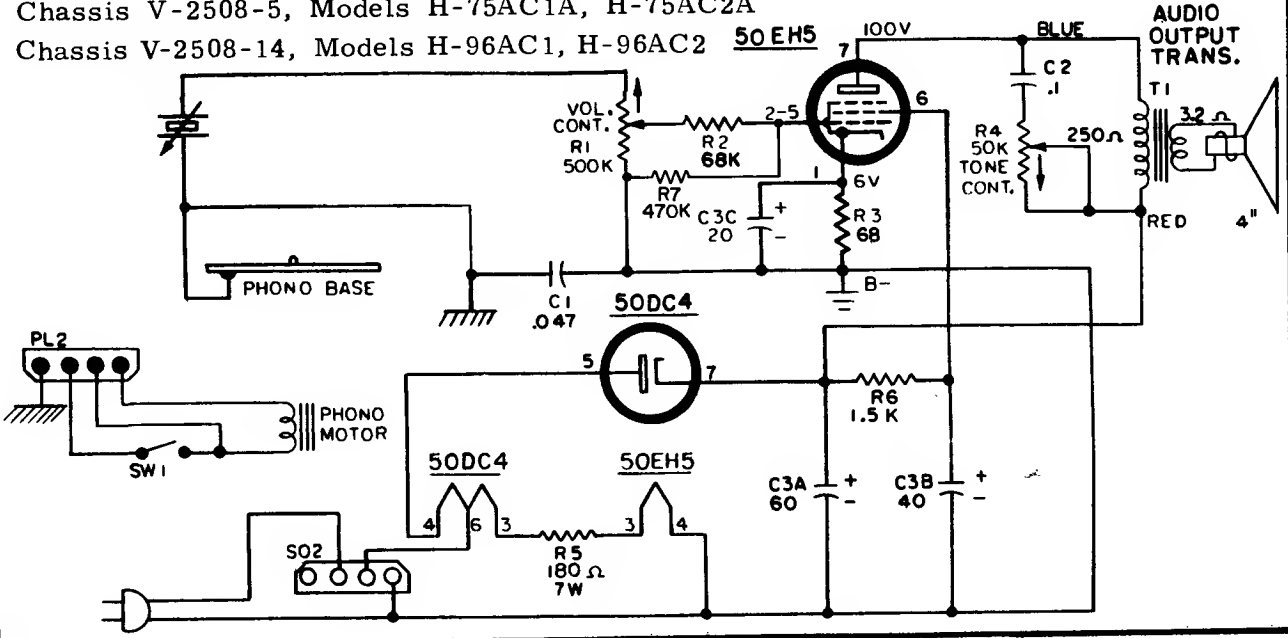

VOLUME R-24, MOST-OFTEN-NEEDED 1964 RADIO SERVICING INFORMATION

WESTINGHOUSE Chassis V-2508-13, Models H-85MP1, H-85MP2, H-85MP3

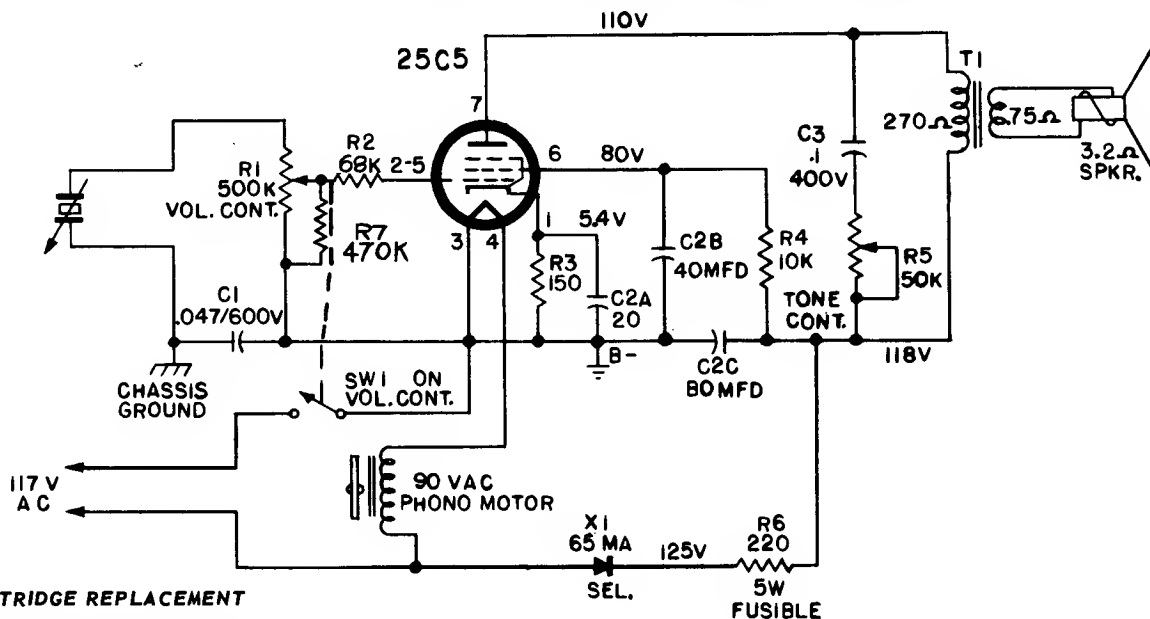

CARTRIDGE REPLACEMENT

1. Remove the knob retainer screw and turnover knob.
2. Pull the cartridge out from the tone arm. Remove the spring, washer, and push-on connectors.

CHASSIS REMOVAL

1. Remove two nylon-head screws from bottom of cabinet base.
2. Remove turntable.
3. Remove two screws located underneath turntable.
4. Snap the edge of the motorboard out of the retaining grooves in the cabinet. Lift motorboard out of cabinet.

CHASSIS REMOVAL

1. Remove the tube service cover.
2. Remove the speaker compartment cover on the left side of the cabinet.
3. Remove the screws holding the motorboard. Lift the motorboard out of the cabinet.
4. Disengage the amp-lok from the changer. Unsolder the leads to the changer terminal board and the leads to the speakers.
5. Remove the control panel screws and lift the control panel out of the cabinet. The chassis is attached to studs on the underside of this panel.

CHASSIS V-2508-11, MODEL H-87ACS1

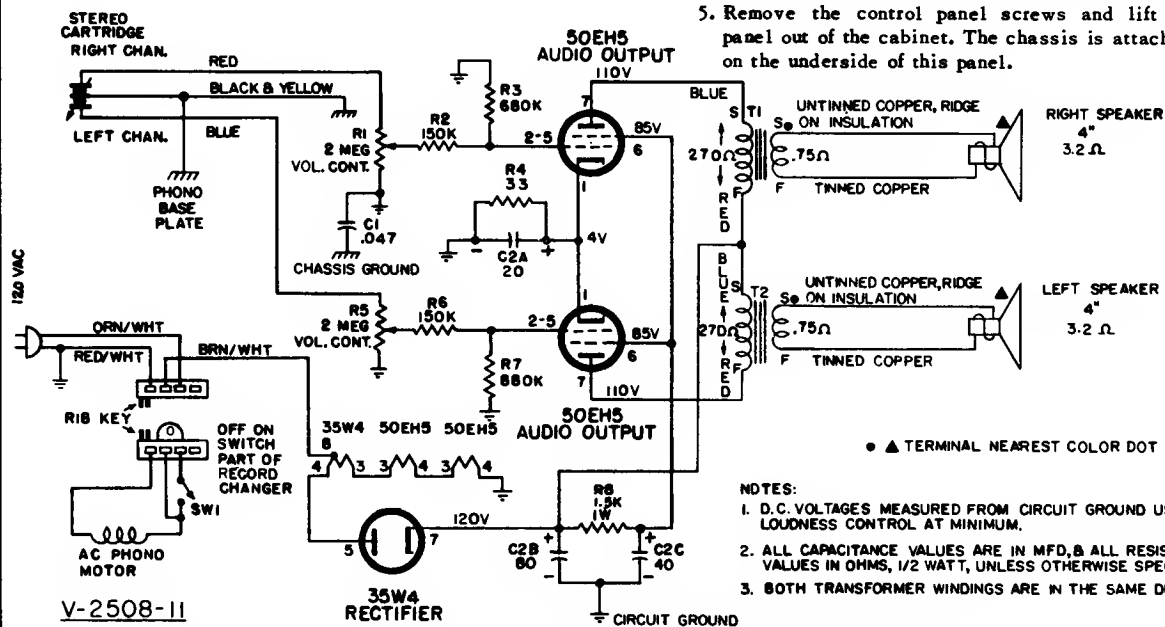

NOTES:

1. D.C. VOLTAGES MEASURED FROM CIRCUIT GROUND USING A V T V M, LOUDNESS CONTROL AT MINIMUM.
2. ALL CAPACITANCE VALUES ARE IN MFD, & ALL RESISTANCE VALUES IN OHMS, 1/2 WATT, UNLESS OTHERWISE SPECIFIED.
3. BOTH TRANSFORMER WINDINGS ARE IN THE SAME DIRECTION.

WESTINGHOUSE Chassis V-2523-1, Model H-89ACS1

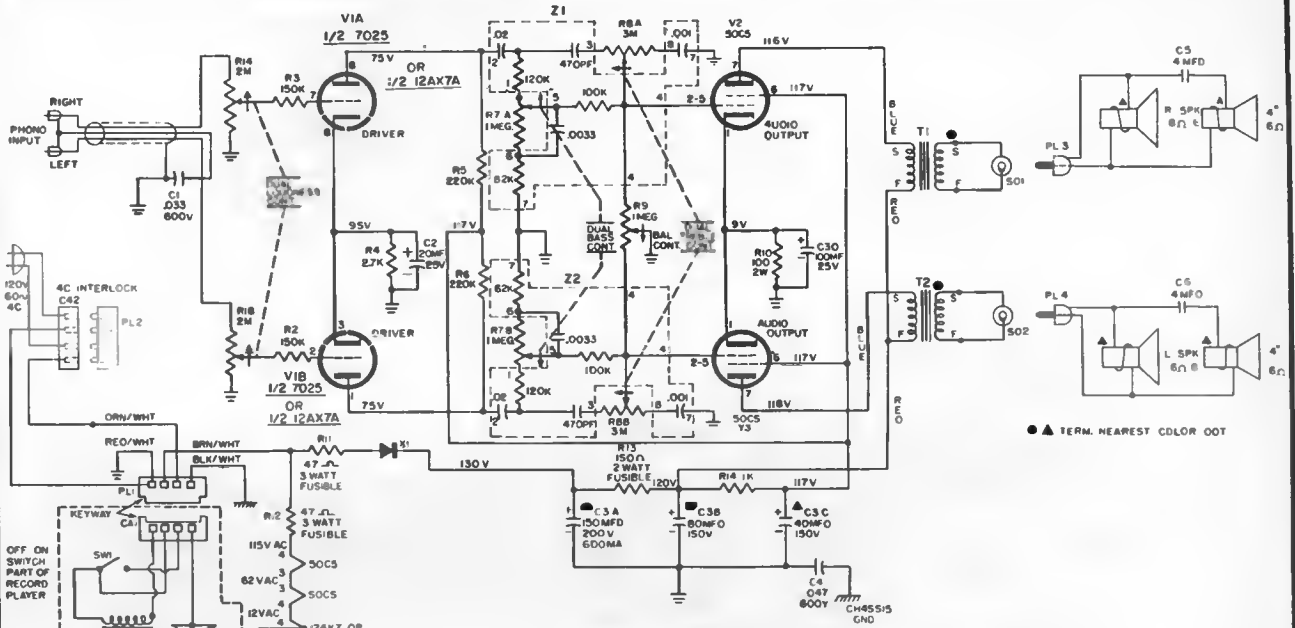

MOTORBOARD REMOVAL

1. Remove 4 rubber feet from bottom of case.
2. Lift entire motor board up and out of the case. Interlock plate screws must be removed before you can lift motor board. Be careful when pulling the motorboard out of the case. See that all components on the bottom of the board clear the case. In some instances it may be necessary to remove the tube service cover and pry the interlock out of its socket.
3. Unsolder the leads connected to phono output jacks. Note the colors and resolder the leads to the same terminals when they are replaced.

CHASSIS REMOVAL FROM MOTORBOARD

1. Remove knobs.
2. Remove 2 screws from control escutcheon.
3. Remove 2 screws from hoard underneath the control escutcheon.
4. Remove 2 screws located underneath the wooden escutcheon. These are accessible through holes in the escutcheon.
5. Disconnect the amplok and phono plug from the changer.
6. Remove one screw holding power supply section of chassis to motorboard.
7. Remove all chicken bands and tape from wires.
8. Remove the screw holding the line cord, located inside the plastic cup.

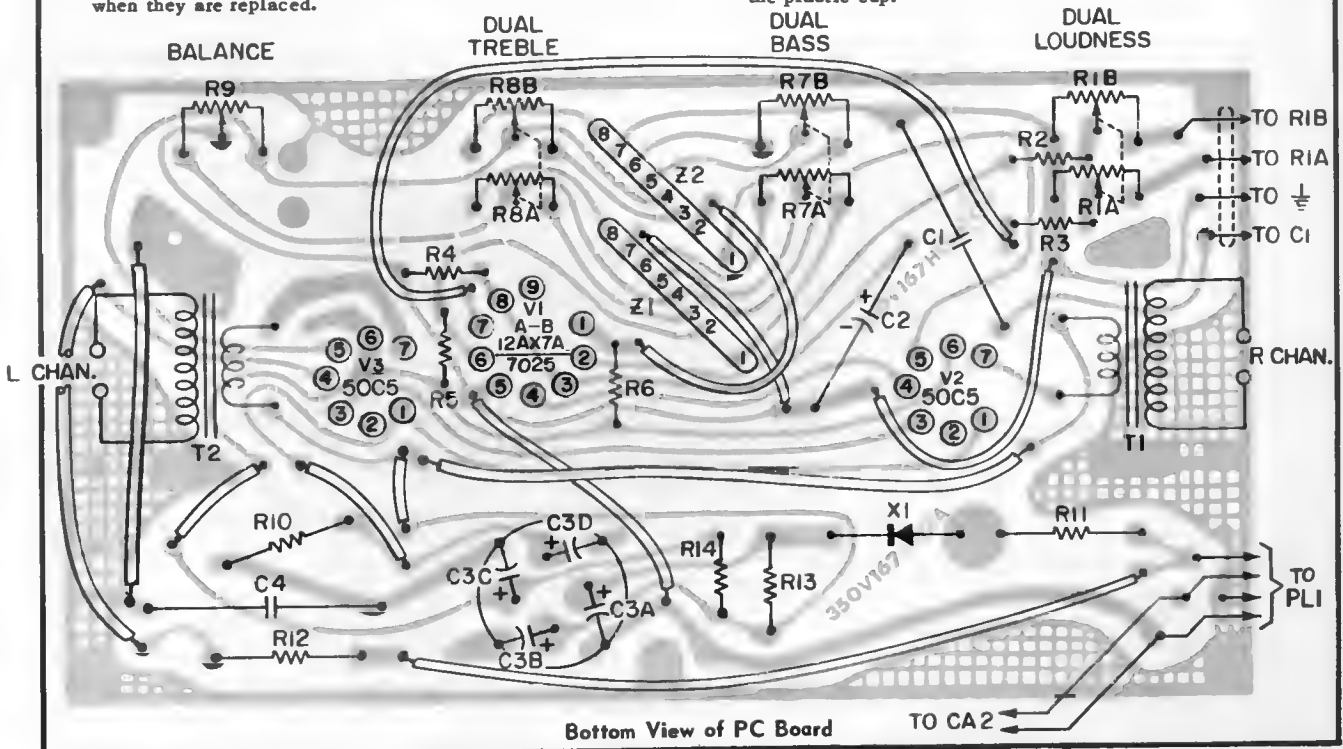

Bottom View of PC Board

WESTINGHOUSE Chassis V-2527-2, Models H-86ACS1A, H-86ACS2A,
Also applicable to Chassis V-2527-1 used in same models and H-86ACS3.

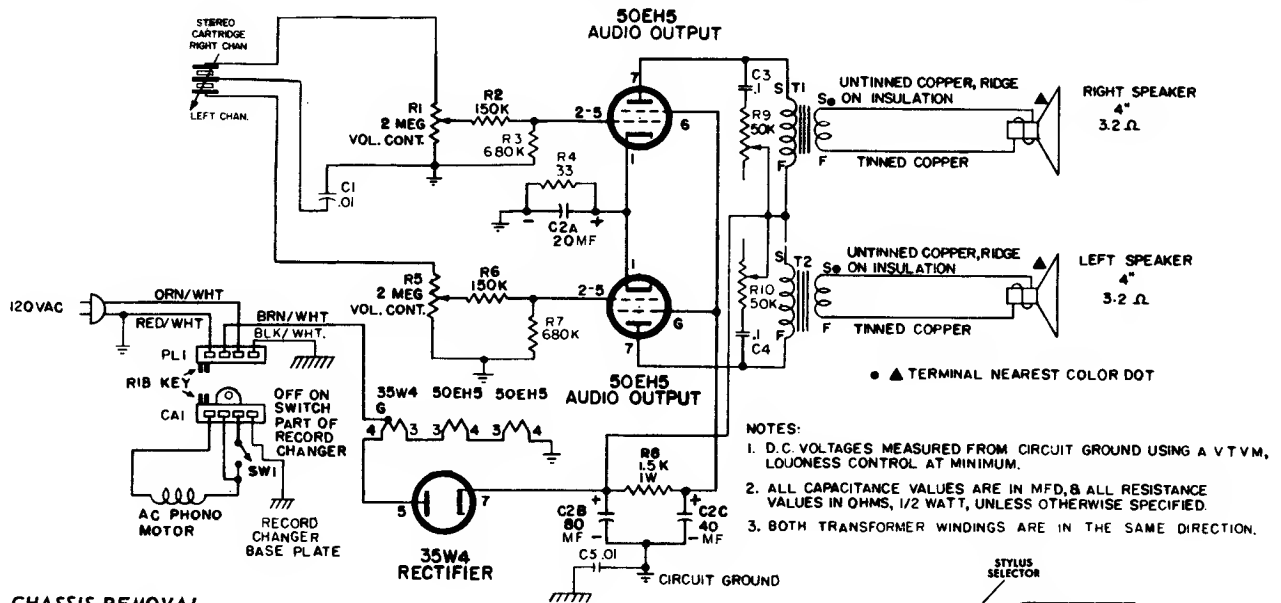

CHASSIS REMOVAL

1. Remove the perforated tube service cover, attached by one phillips screw.
2. Remove 4 phillips screws holding the motor-board. Lift the motor-board out of the cabinet.
3. Disengage the amp-lok and unsolder the three input leads to the amplifier. Unsolder the leads connected to the output transformers.
4. Remove the 3 knobs.
5. Remove the 4 speed nuts holding the chassis to the cabinet side. Remove the chassis from the cabinet.

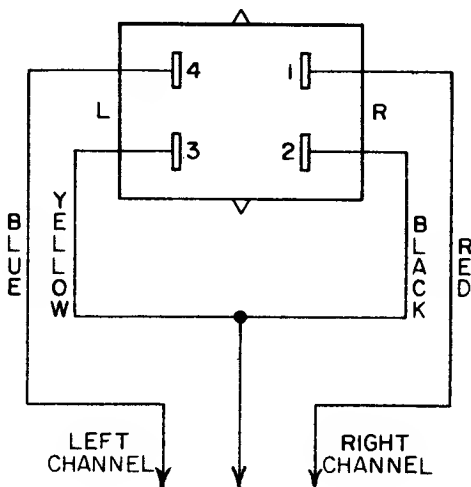

Figure 1 - Cartridge Wiring Diagram

CARTRIDGE REPLACEMENT (CHASSIS V-2527-2)

1. Observe the sequence of wires, as shown in Figure 1.
2. Remove the push-on connectors from the terminals.
3. Remove the cartridge, pulling it away from the cartridge holder. CAUTION: A spring and 2 washers are located on the mounting shaft.

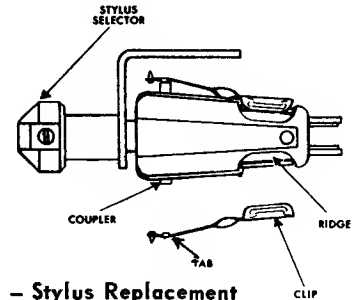

Figure 2 - Stylus Replacement

4. Slide the new cartridge into the cartridge holder with the stylus marked SA-250 facing in the same direction as the side of the stylus marking 33-45.
5. Apply slight pressure to the rear of the cartridge to align the holes in the stylus selector knob and mounting shaft. Replace the screw in the stylus selector knob.

STYLUS REPLACEMENT (see Figure 2)

1. Pull the stylus clip off the cartridge ridge.
2. Push the clip of the replacement stylus onto the ridge.
3. Lift the front part of the stylus a small amount so that it is not pressing against the coupler - then let it fall back and engage the coupler. The tabs on the stylus should be centered, with one on each side of the projecting end of the coupler.

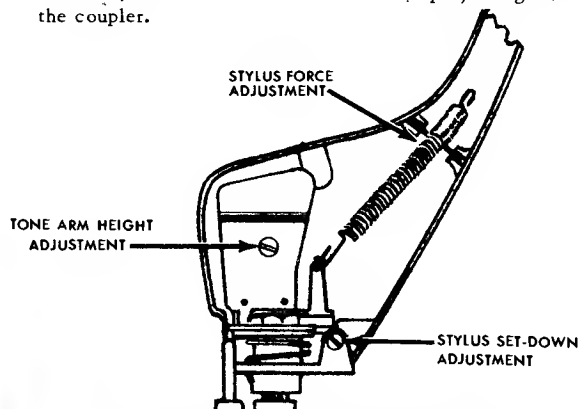
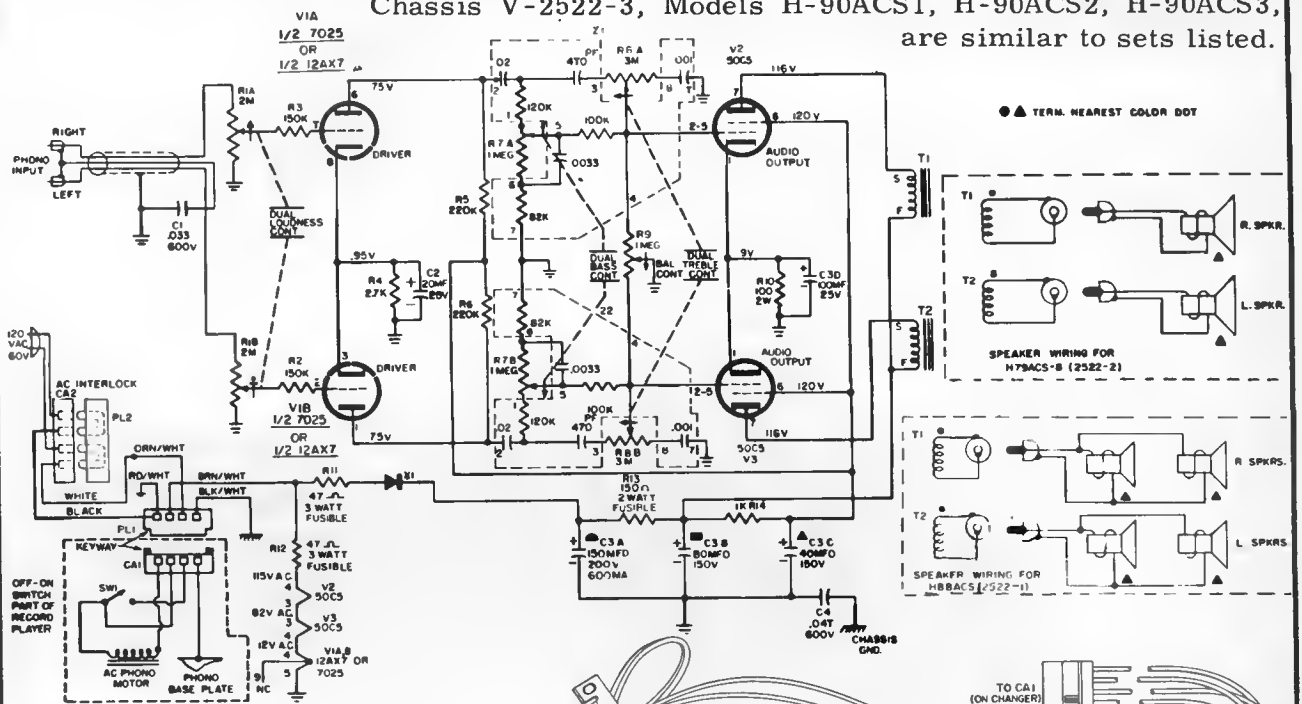

Figure 3 - Tone Arm Adjustments

VOLUME R-24, MOST-OFTEN-NEEDED 1964 RADIO SERVICING INFORMATION

WESTINGHOUSE Chassis V-2522-1, -2, Models H-79ACS1B, H-79ACS2B, H-88ACS1
 Chassis V-2522-3, Models H-90ACS1, H-90ACS2, H-90ACS3,
 are similar to sets listed.



- NOTES**
- 1 DC VOLTAGES MEASURED FROM CIRCUIT GROUND USING A VTVM, LOUDNESS CONTROL AT MINIMUM
 - 2 ALL CAPACITANCE VALUES ARE IN MFD. ALL RESISTANCE VALUES IN OHMS, 1/2 WATT UNLESS OTHERWISE SPECIFIED
 - 3 REAR SECTIONS OF CONTROLS ARE RIGHT CHANNEL.
 - 4 CHASSIS GROUND - B - COMMON GROUND
 - 5 ARROWS ON CONTROLS INDICATE CLOCKWISE ROTATION (CONTROL VIEWED FROM SHAFT END)

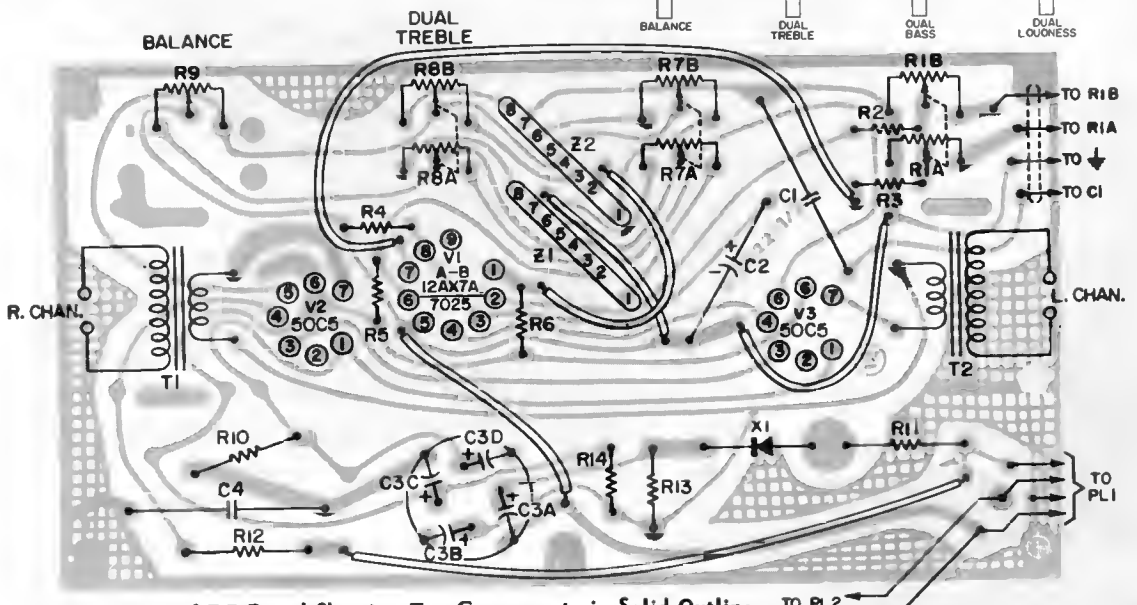
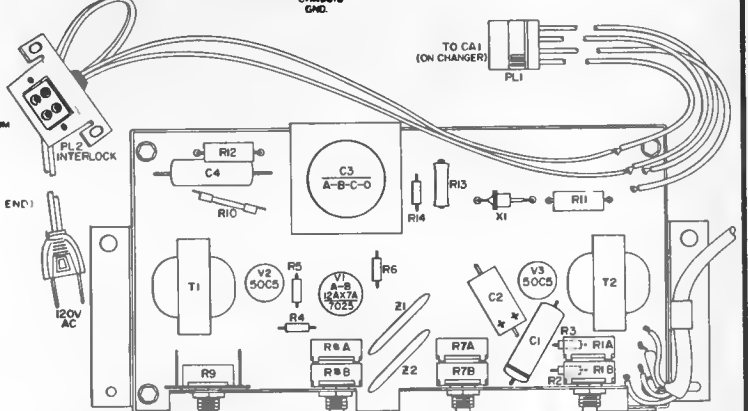

Bottom View of PC Board Showing Top Components in Solid Outline. TO PL2

Westinghouse

(Continued on page at right)

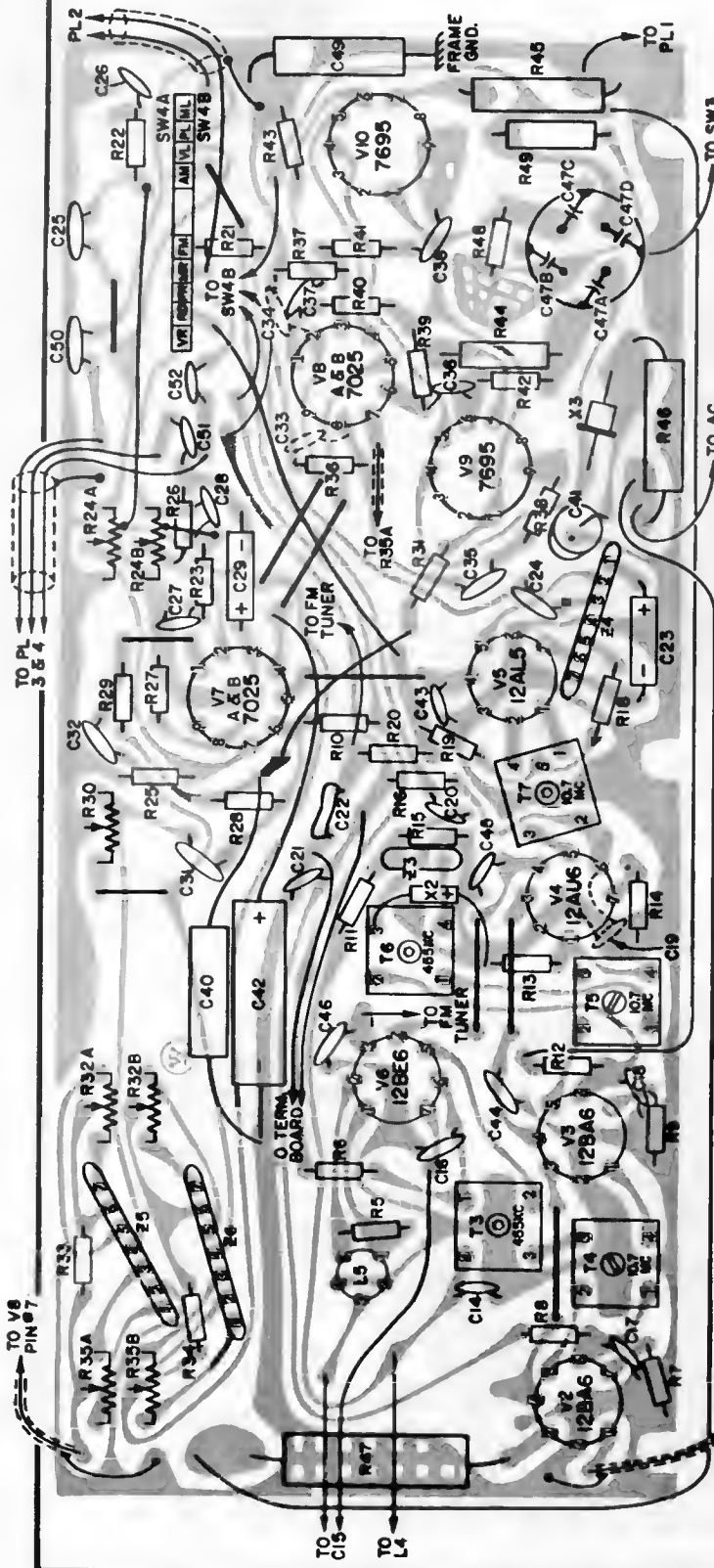

Bottom view of Chassis V-2515-4 PC board showing location of top components in solid outline. Tube pin numbering is for bottom of socket.

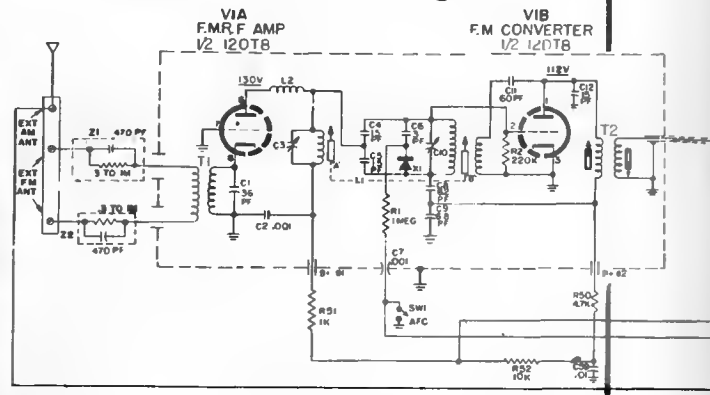

MODELS

- H-M1790 H-M1810/A/B
- H-M1791 H-M1811/A/B
- H-M1793 H-M1813/A/B
- H-M1793 H-M1815/A/B

H-M1910 (walnut)

H-M1911 (cherry)

H-M1913 (maple)

H-M1914 (butternut)

CHASSIS V-2515-4

and similar Models H-M1760, H-M1761, H-M1763, using Chassis V-2515-8.

(Continued on the next page adjacent at right)

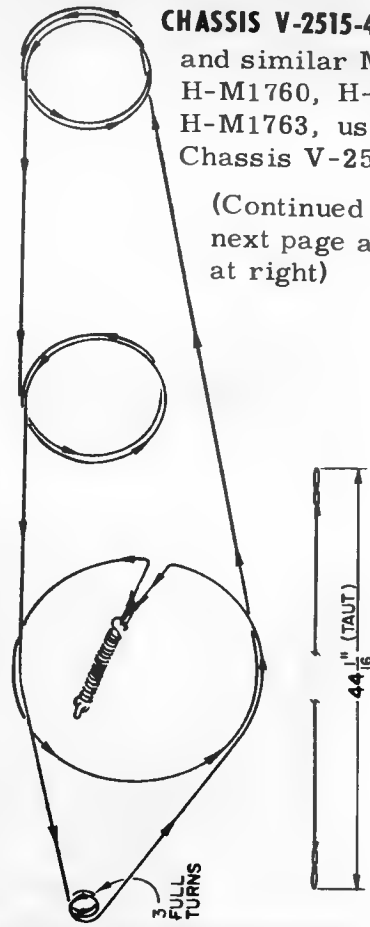

Diol Cord Stringing

VOLUME R-24, MOST-OFTEN-NEEDED 1964 RADIO SERVICING INFORMATION

WESTINGHOUSE Chassis V-2515-4, Models H-M1810/A/B, H-M1811/A/B, H-M1813/A/B, H-M1815/A/B, H-M1910, H-M1911, H-M1913, and H-M1914, and others models,

continued from preceding page.

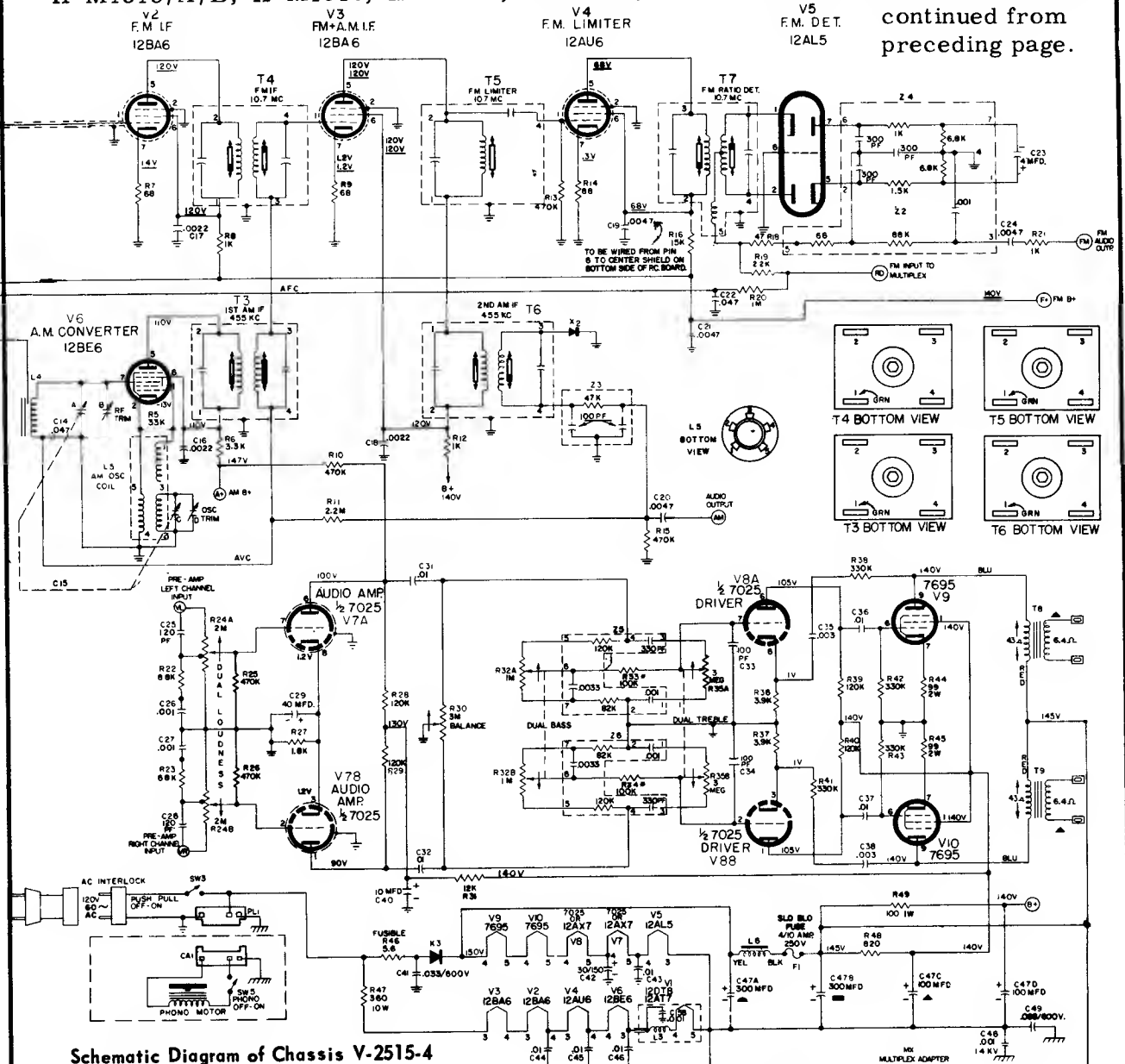

Schematic Diagram of Chassis V-2515-4

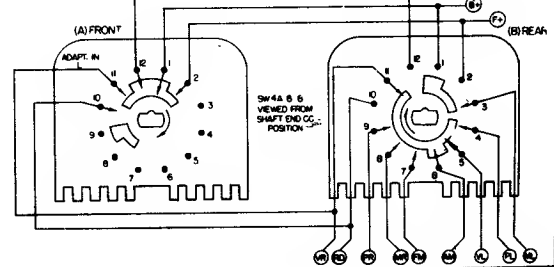
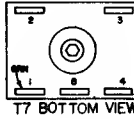
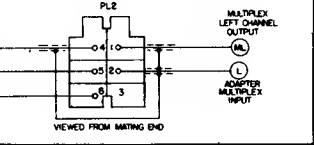
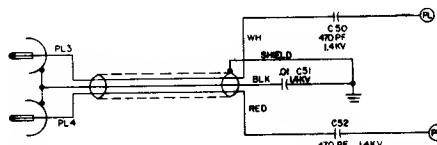

- ALL CAPACITANCE VALUES IN MFD. AND ALL RESISTANCE VALUES IN OHMS, $\frac{1}{2}$ WATT, UNLESS OTHERWISE SPECIFIED.
- D.C. VOLTAGES MEASURED FROM POINTS INDICATED TO CIRCUIT GROUND, NO SIGNAL APPLIED, USING A V.T.V.M., LINE VOLTAGE SET AT 120 VAC.
- * R33 & R34 NOT INCLUDED IN PACKAGE CIRCUITS Z5 & Z6.
- UNDERLINED VOLTAGES ARE TAKEN IN FM POSITION.
- ALL REFERENCES TO LEFT & RIGHT ARE AS VIEWED FACING FRONT OF SET
- SW4A, B IS SHOWN IN THE CCW POSITION, (AM POSITION)
- REAR SECTIONS OF CONTROLS (FARTHEST FROM SHAFTS) ARE RIGHT CHANNEL.
- ARROWS ON CONTROLS INDICATE CW ROTATION (CONTROL VIEWED FROM SHAFT END)

VOLUME R-24, MOST-OFTEN-NEEDED 1964 RADIO SERVICING INFORMATION

ZENITH Model Royal 130, Chassis 6KT47Z1

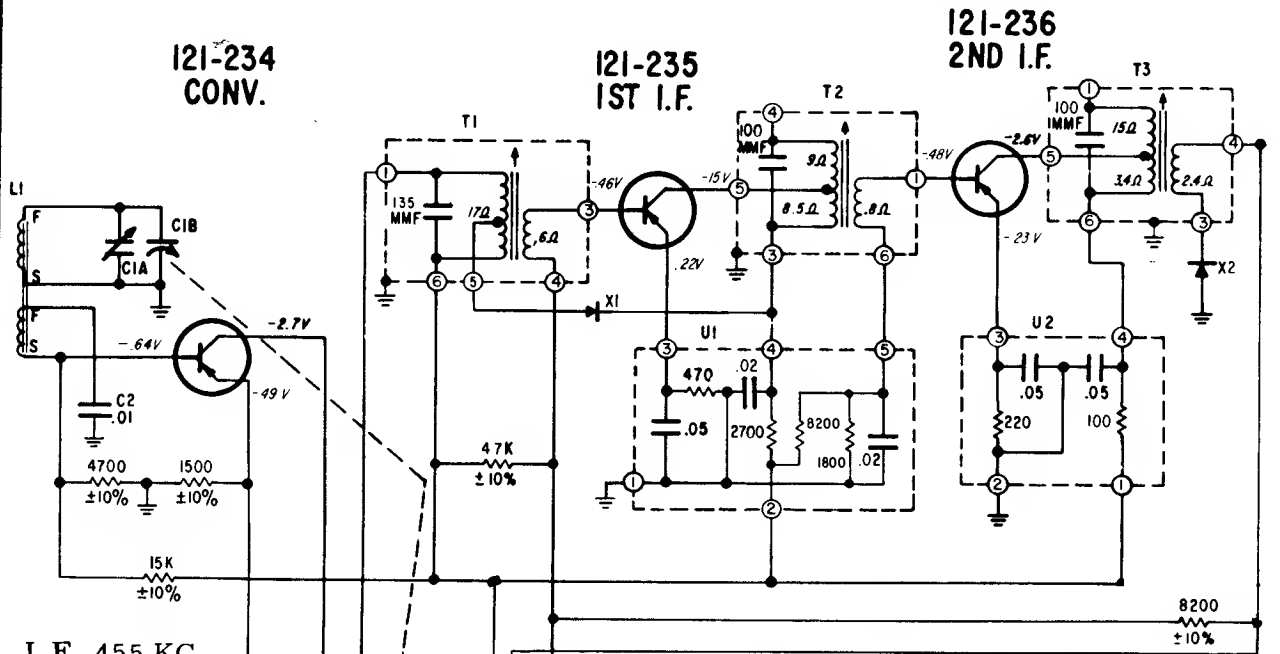

I. F. 455 KC.

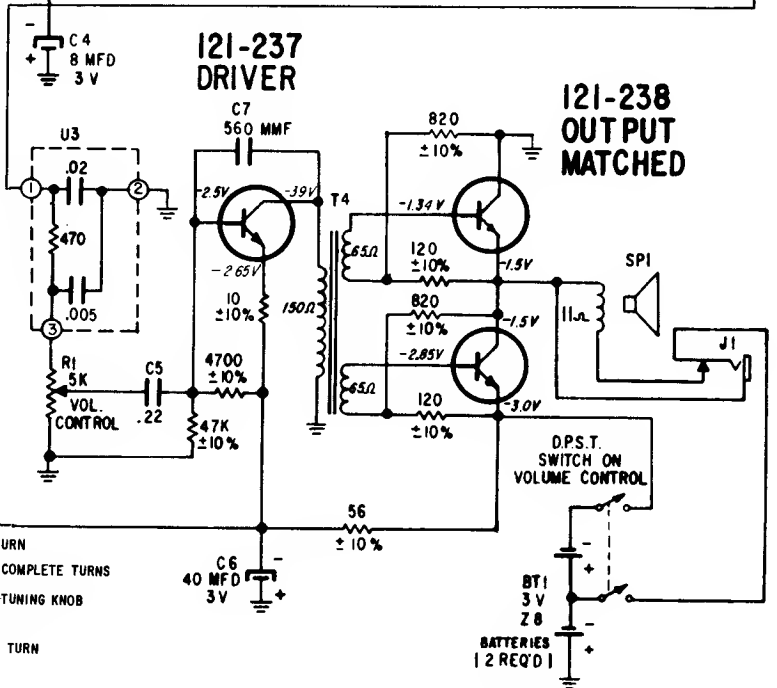

COLLECTOR
 SOLDER IN TYPE TRANSISTOR
 BASE
 EMITTER

NPN TRANSISTOR



PNP TRANSISTOR

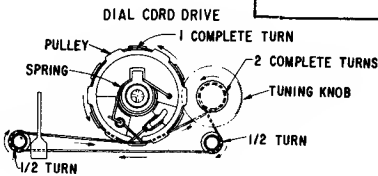
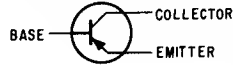

SHOWN WITH GANG IN FULL CCW POSITION AS VIEWED FROM FRONT OF CHASSIS.

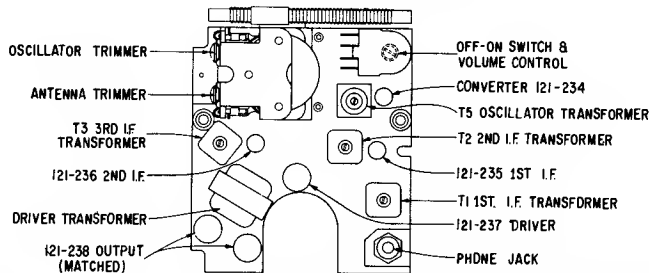

NOTES:

ALL RESISTORS ARE CARBON, 1/2 WATT, ±20% TOLERANCE UNLESS OTHERWISE SPECIFIED.
 ALL VOLTAGES ARE D.C. UNLESS OTHERWISE SPECIFIED.
 ALL CONDENSERS ARE IN MICROFARADS UNLESS OTHERWISE SPECIFIED.
 D.C. VOLTAGES SHOWN ARE MEASURED FROM GROUND WITH NO SIGNAL USING A VACUUM TUBE VOLTMETER.
 † DENOTES GROUND.

BATTERY CURRENT DRAIN: APPROXIMATELY 12 M.A. WITH VOLUME CONTROL AT MINIMUM.

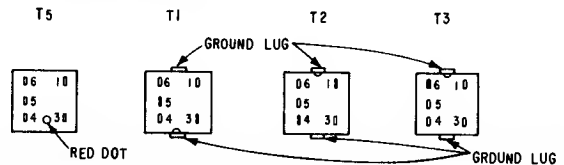

ZENITH RADIO MODELS L519C, F, G, W CHASSIS 5L07

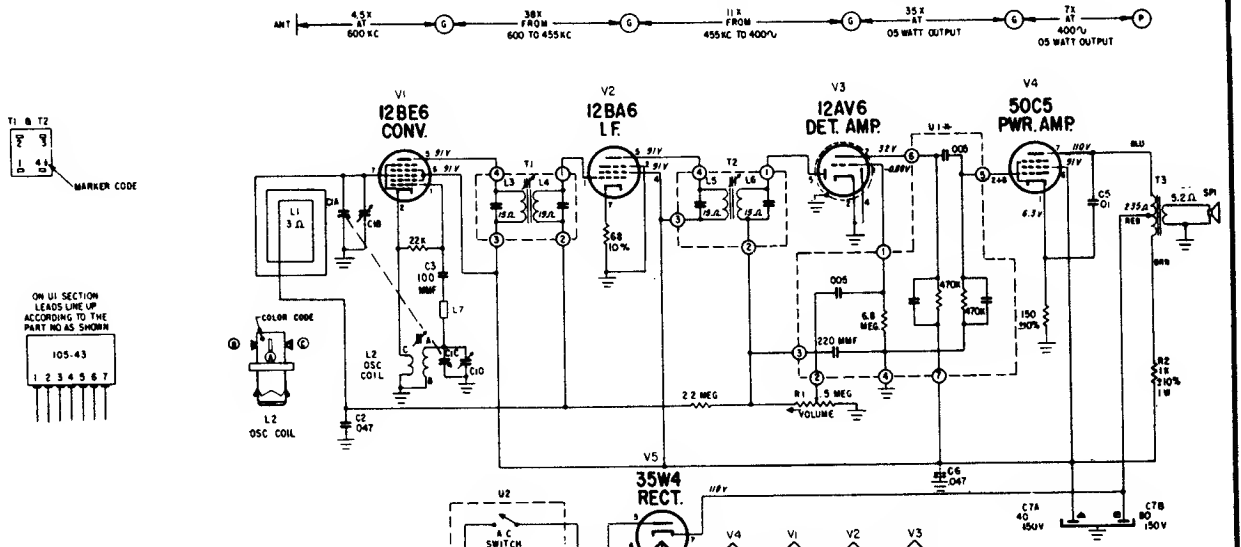

NOTES

ALL VOLTAGES MEASURED FROM CHASSIS TO POINTS INDICATED WITH A V.T.V.M.

USE ONLY ZENITH NON-INDUCTIVE ELECTROLYTIC CONDENSERS FOR REPLACEMENT. IF ANY OTHER TYPE OF ELECTROLYTIC IS USED IT WILL BE NECESSARY TO ADD C6 SHOWN IN DOTTED LINES.

I.F. TRANSFORMER NUMBERING STARTS WITH R1 TERMINAL AS FIRST TERMINAL CLOCKWISE FROM MARKER CODE TERMINAL AS VIEWED FROM BOTTOM OF CHASSIS.

I.F. FREQUENCY 455 KC

TUNING RANGE 535-1620 KC

ALL RESISTORS 20% TOLERANCE, 1/2 WATT, CARBON UNLESS OTHERWISE SPECIFIED.

ALL CAPACITOR VALUES IN MICROFARADS UNLESS OTHERWISE SPECIFIED.

DENOTES CHASSIS

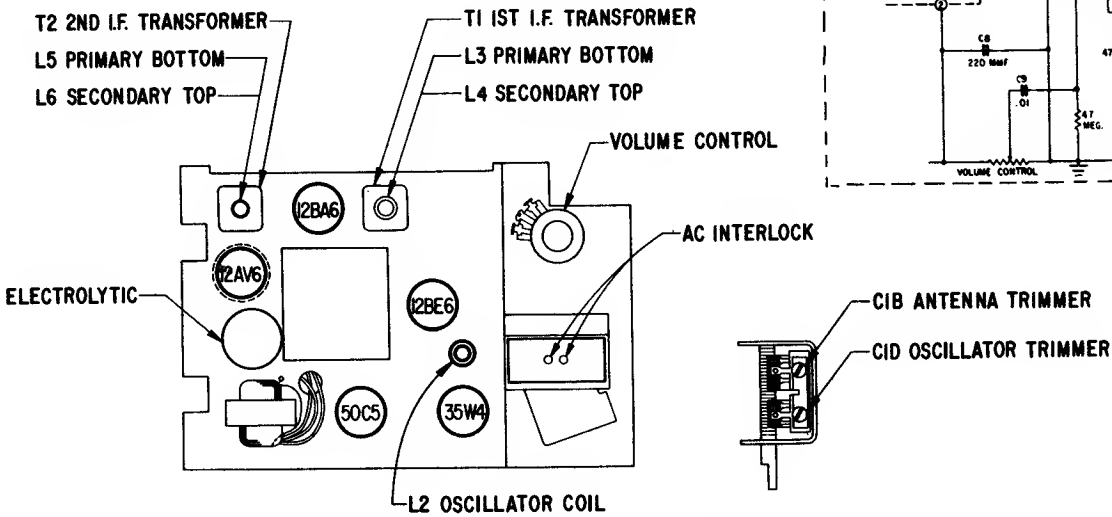
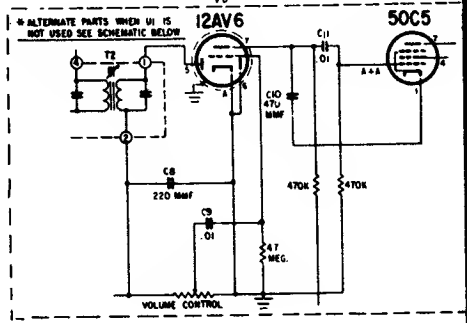

ALIGNMENT PROCEDURE

Operation	Connect Oscillator To	Dummy Antenna	Input Sig. Frequency	Set Dial At	Trimmers	Purpose
1	Converter Grid	.5 Mfd.	455 Kc.	600 Kc.	L3,L4,L5, L6	For I.F. Alignment.
2	One Turn Loop Coupled Loosely to Wave Magnet	—	1600 Kc.	1600 Kc.	C1D	Set Oscillator to Dial Scale
3		—	1400 Kc.	1400 Kc.	C1B	Align Antenna Stage



121-235
 1ST I.F.

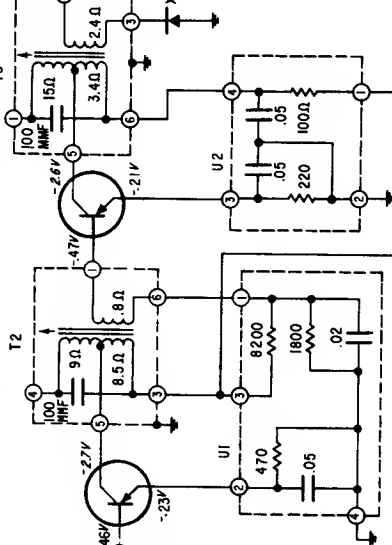
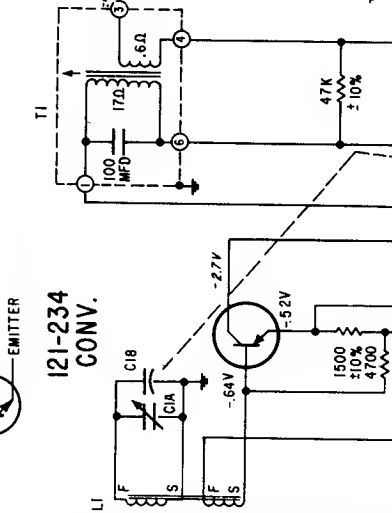

121-237
 DRIVER

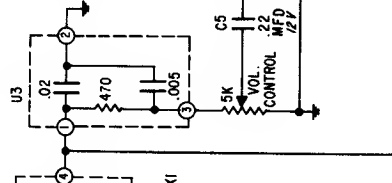

121-238
 OUTPUT
 MATCHED

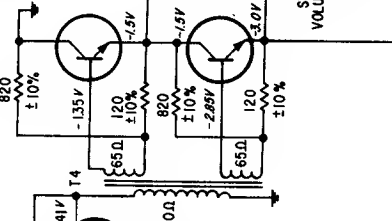

NOTES:
 ALL RESISTORS ARE CARBON, 1/2 WATT, ±20% TOLERANCE UNLESS OTHERWISE SPECIFIED.
 ALL VOLTAGES ARE D.C. UNLESS OTHERWISE SPECIFIED.
 ALL CONDENSERS ARE IN MICROFARADS UNLESS OTHERWISE SPECIFIED.
 D.C. VOLTAGES SHOWN ARE MEASURED FROM GROUND WITH NO SIGNAL USING A VACUUM TUBE VOLTMETER.
 ↓ DENOTES GROUND.
 BATTERY CURRENT DRAIN: APPROXIMATELY 12 M.A. WITH VOLUME CONTROL AT MINIMUM.

CHASSIS 6KT40Z1

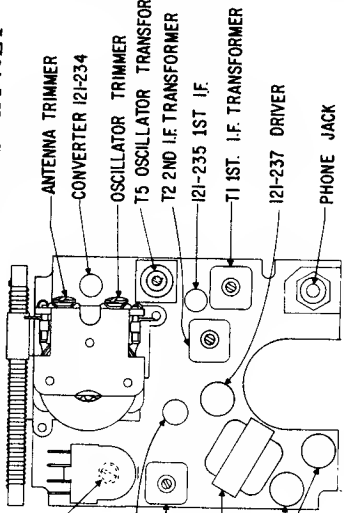

TRANSISTOR & TRIMMER
 LAYOUT FOR CHASSIS 6KT40Z1

ZENITH Model Royal 50L
 using Chassis 6KT40Z1

(For alignment information see
 data on next page, at right)

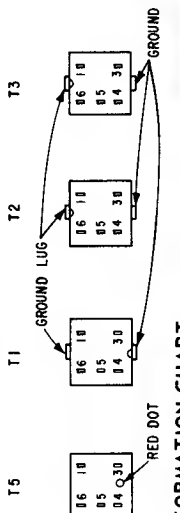

CHASSIS INFORMATION CHART

Chassis	Transistor Layout Label Color	Part No.	Conv.	1st I.F.	2nd I.F.	Crystal Diode Detector	Driver	Output-Output	Supplier
6KT40Z1	Black 102-9403	Zenith E1A Type	121-234 GC282 PNP	121-235 GC283 PNP	121-236 GC284 PNP	103-44 IN191	121-237 GC286 NPN	121-238 GC285 Matched Pair NPN NPN	Texas Instrument
6KT40Z8	Red 102-9419	Zenith E1A Type	121-244 2N993 PNP	121-242 2N993 PNP	121-243 2N993 PNP	103-44 IN191	121-245 C-1438 PNP	121-246 C-1437 Matched Pair PNP PNP	AMPREX

12I-246
OUTPUT
MATCHED

12I-245
DRIVER

12I-243
2ND I.F.

12I-242
1ST I.F.

PNP TRANSISTOR

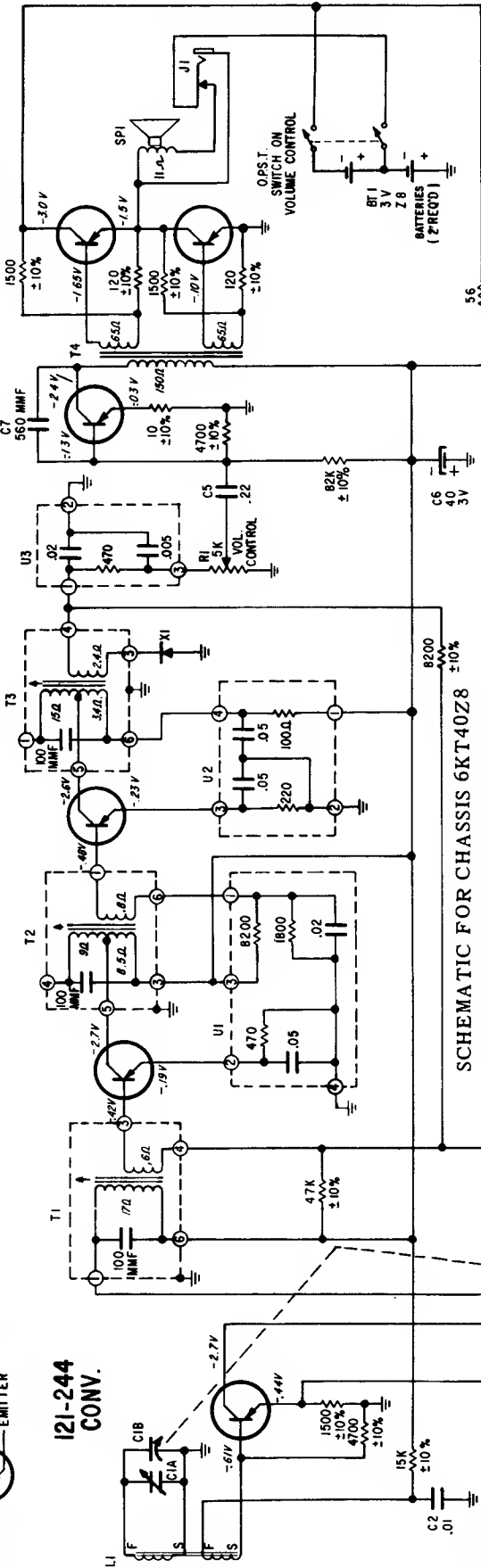

SCHEMATIC FOR CHASSIS 6KT40Z8

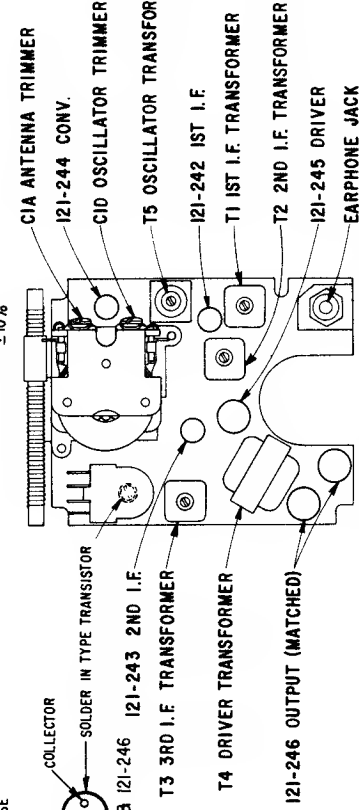

TRANSISTOR & TRIMMER
LAYOUT FOR CHASSIS 6KT40Z8

ZENITH Model Royal 50L
using Chassis 6KT40Z8

(For schematic notes and other
information see preceding page)

ALIGNMENT PROCEDURE

Operation	Input Signal Frequency	Connect Inner Conductor From Oscillator To	Set Dial At	Trimmers	Purpose
1	455 KC	ONE TURN	600 KC	Adj. T1, T2, T3 for maximum output.	For I.F. Alignment
2	1620 KC	LOOSELY COUPLED	Gang wide open.	CID	Set Oscillator to dial scale
3	600 KC	TO WAVEMAGNET	Near 600 KC	Adjust slug in T5	While rocking gang, adjust T5 for maximum output regardless of dial accuracy.
4	1260 KC		1260 KC	CIA	Align loop ant.
5	REPEAT STEPS 2 & 3				

VOLUME R-24, MOST-OFTEN-NEEDED 1964 RADIO SERVICING INFORMATION

ZENITH Models 265, 645, 670, Chassis 6KT41Z1, 6KT42Z1, 6KT45Z1

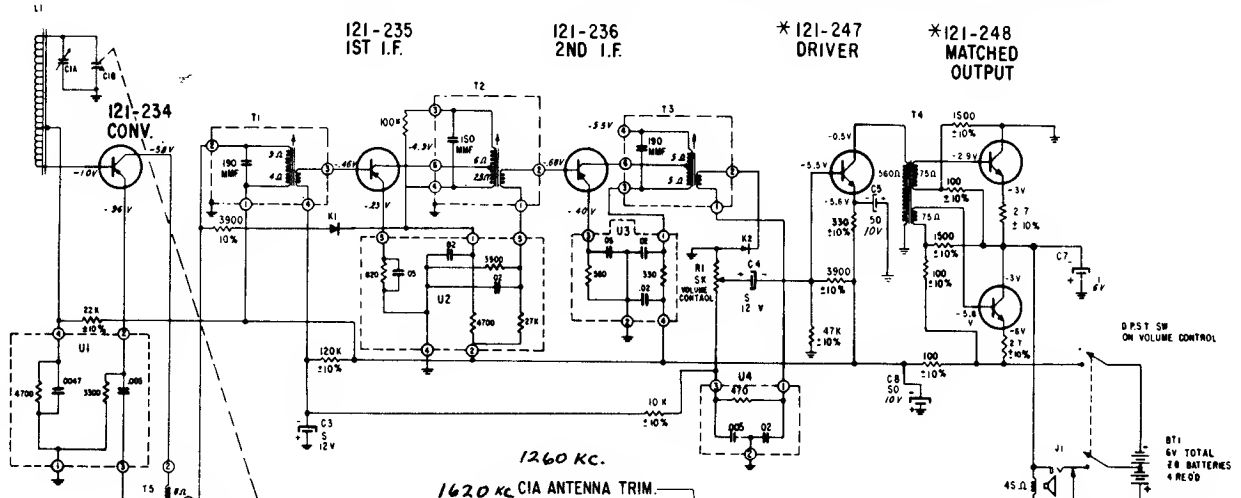

SCHEMATIC FOR CHASSIS 6KT42Z1

NOTES:
 ALL RESISTORS ARE CARBON, 1/2 WATT, ±20% TOLERANCE UNLESS OTHERWISE SPECIFIED.
 ALL VOLTAGES ARE D.C. UNLESS OTHERWISE SPECIFIED.
 ALL CAPACITORS ARE IN MICROGRAMS UNLESS OTHERWISE SPECIFIED.
 D.C. VOLTAGES SHOWN ARE MEASURED FROM CHASSIS WITH NO SIGNAL USING A VACUUM TUBE VOLTMETER.
 DEMOTES CHASSIS
 BATTERY CURRENT DRAIN APPROX. 4.5 MA WITH VOLUME CONTROL AT MINIMUM.
 *SPEAKER IMPEDANCE 22Ω AT 400 CPS

T5 COLOR CODE

D 4	4 D
D 3	
D 4	3 D

DRIVER	MATCHED OUTPUT
121-247	121-248
VIOLET	BLACK
BLACK	VIOLET
WHITE	BLUE

* THE MATCHING IDENTIFICATION WILL BE A COLORED DOT.
 THE MATCHING OF TRANSISTORS WILL BE AS INDICATED IN THE ABOVE CHART

PNP TRANSISTORS

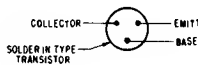
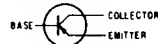

NPN TRANSISTOR



TRANSISTOR & TRIMMER LAYOUT FOR CHASSIS 6KT45Z1 & 6KT41Z1

121-235 1ST I.F.
 121-236 2ND I.F.
 *121-247 DRIVER
 *121-248 MATCHED OUTPUT

455 KC. T2 2ND I.F. TRANS.
 600 KC. T5 OSCILLATOR TRANS.
 455 KC. T1 1ST I.F. TRANS.
 T3 3RD I.F. TRANS.

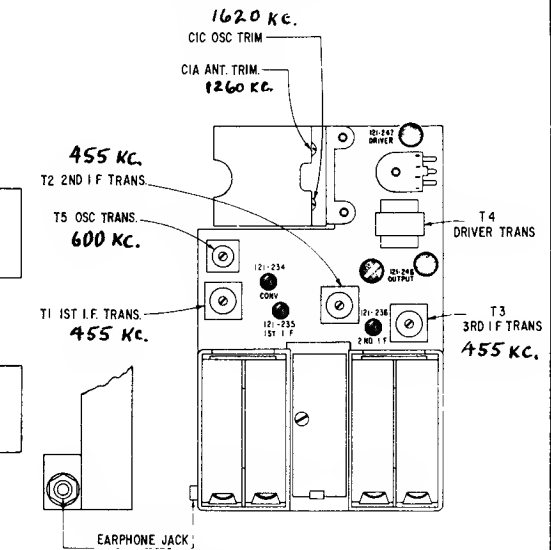

TRANSISTOR & TRIMMER LAYOUT FOR CHASSIS 6KT42Z1

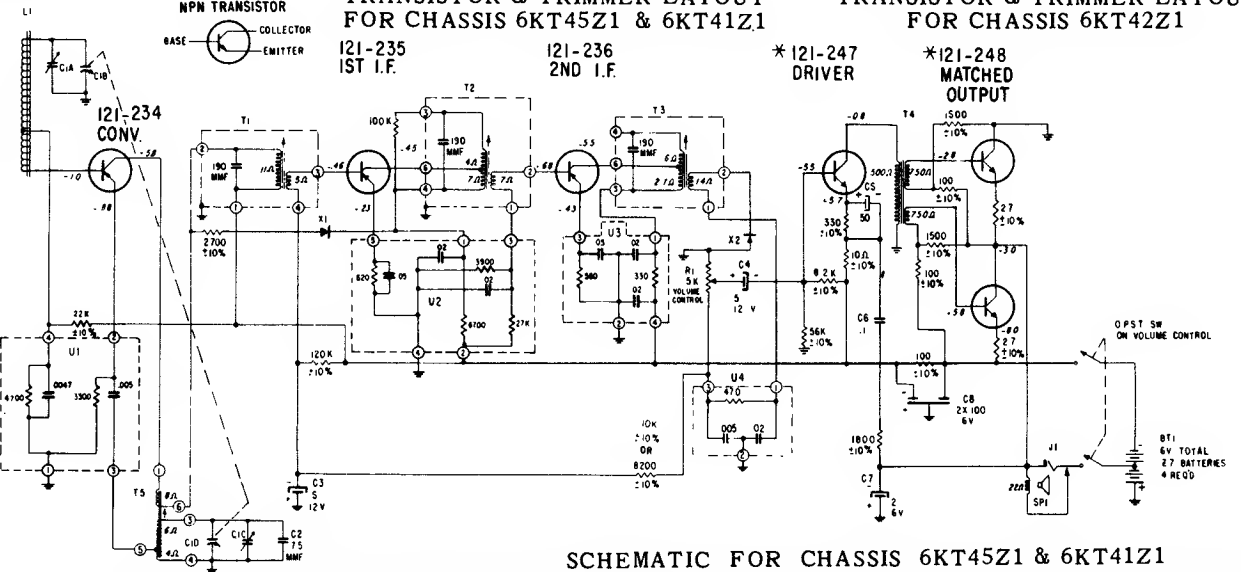

SCHEMATIC FOR CHASSIS 6KT45Z1 & 6KT41Z1

VOLUME R-24, MOST-OFTEN-NEEDED 1964 RADIO SERVICING INFORMATION

ZENITH MODELS 265, 645, 670, CHASSIS 6KT41Z1, 6KT42Z1, 6KT45Z1

(Diagram on preceding page)

CHASSIS, WIRING AND COMPONENTS
VIEWED FROM WIRING SIDE

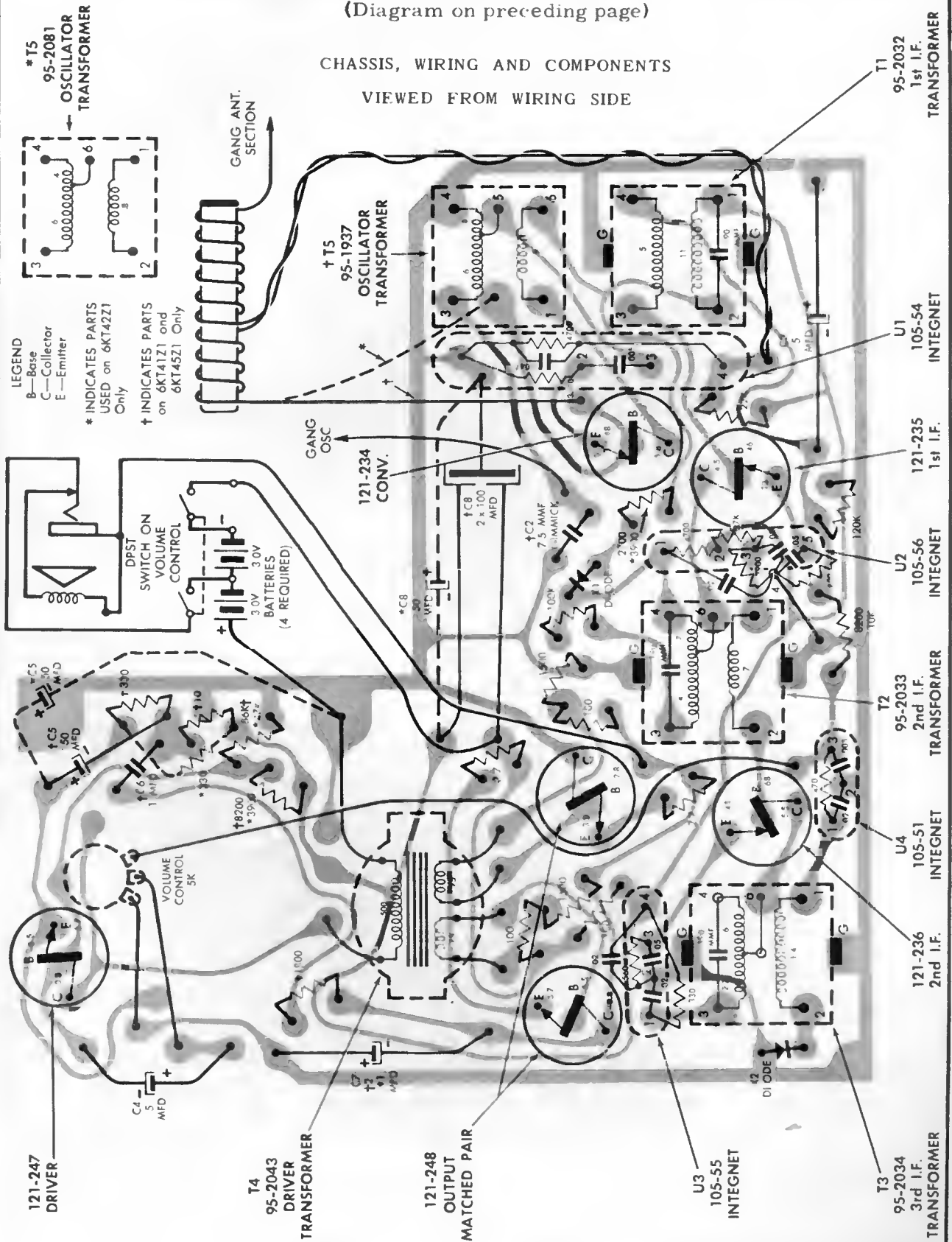

LEGEND
 B—Base
 C—Collector
 E—Emitter

* INDICATES PARTS USED ON 6KT42Z1 Only
 † INDICATES PARTS USED ON 6KT41Z1 and 6KT45Z1 Only

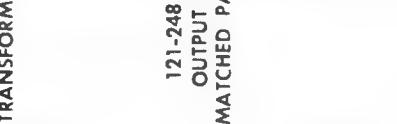
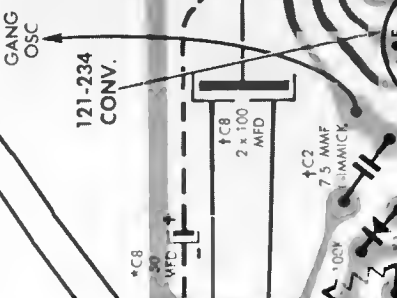
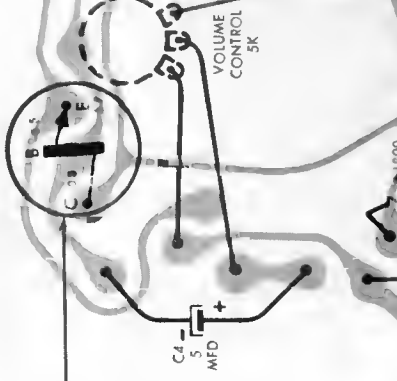
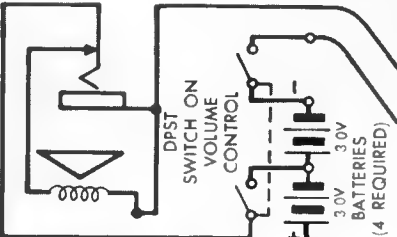
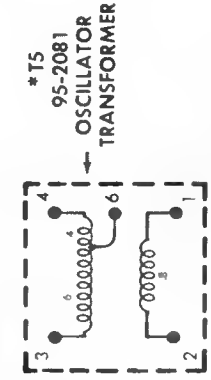

VOLUME R-24, MOST-OFTEN-NEEDED 1964 RADIO SERVICING INFORMATION

ZENITH Model "Royal 490" Chassis 7KT45Z1

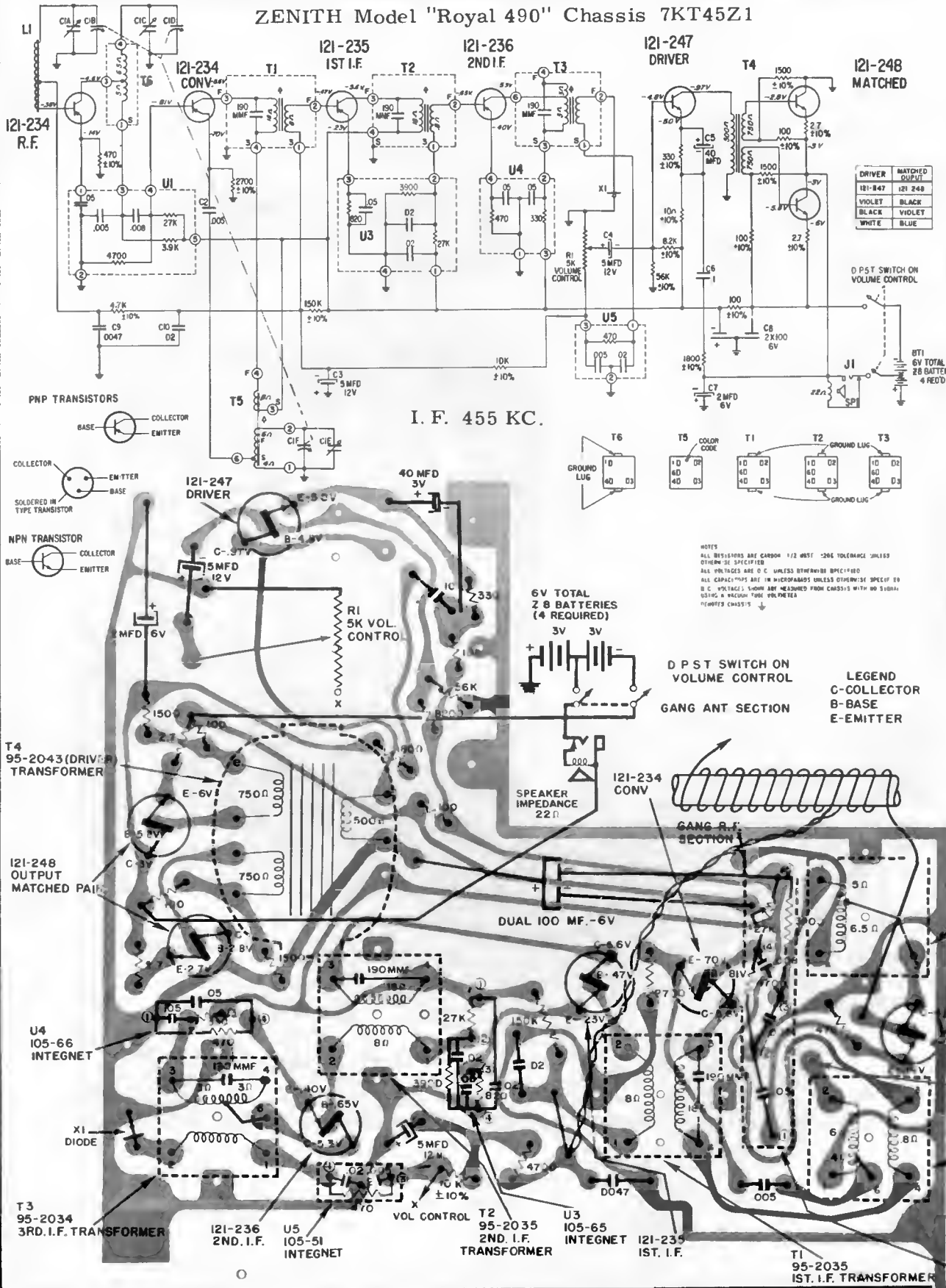

DRIVER	MATCHED OUTPUT
121-247	121-248
VIOLET	BLACK
BLACK	VIOLET
WHITE	BLUE

I. F. 455 KC.

NOTES
ALL RESISTORS ARE CARBON 1/2 WATT ±5% TOLERANCE UNLESS OTHERWISE SPECIFIED
ALL CAPACITORS ARE IN MICROFARADS UNLESS OTHERWISE SPECIFIED
ALL CAPACITORS ARE IN MICROFARADS UNLESS OTHERWISE SPECIFIED
D.C. VOLTAGE IS SHOWN AND REQUIRED FROM CHASSIS WITH NO SIGNAL
USING A MATCHING TOOL UNLESS INDICATED OTHERWISE

LEGEND
C-COLLECTOR
B-BASE
E-EMITTER

D.P.S.T. SWITCH ON VOLUME CONTROL

DUAL 100 MF.-6V

6V TOTAL
2 8 BATTERIES
(4 REQUIRED)

SPEAKER IMPEDANCE
22 Ω

VOL CONTROL

T2 95-2035
2ND. I.F. TRANSFORMER

U3 105-65
INTEGNET

U5 105-51
INTEGNET

U4 105-66
INTEGNET

U1 105-63
INTEGNET

GANG ANT SECTION

GANG R.F. SECTION

GANG OSCILLATOR SECTION

VOLUME R-24, MOST-OFTEN-NEEDED 1964 RADIO SERVICING

ZENITH RADIO Model K615B, C, W, Chassis 6K05

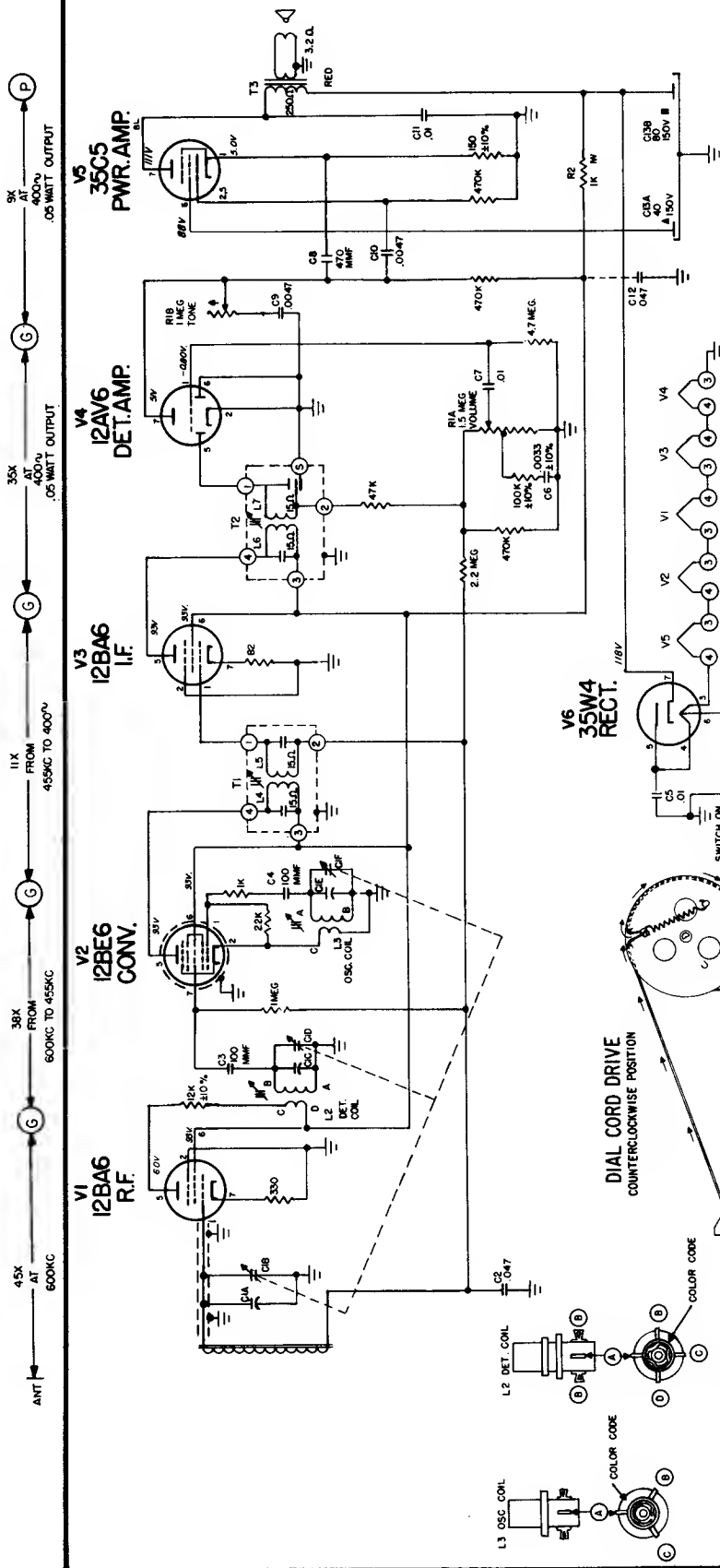

NOTES:
 ALL VOLTAGES MEASURED FROM CHASSIS TO POINTS INDICATED WITH AC-DC OR VACUUM TUBE VOLTMETER.
 ALL RESISTORS ARE 5% TOLERANCE, 1/2 WATT CARBON UNLESS OTHERWISE SPECIFIED.
 ALL CAPACITOR VALUES IN MICROFARADS UNLESS OTHERWISE SPECIFIED.
 USE ONLY ZENITH NON-INDUCTIVE ELECTROLYTIC CONDENSERS FOR RE-PAIR.
 IF ANY OTHER TYPE OF ELECTROLYTIC IS USED, IT WILL BE NECESSARY TO ADD C12 SHOWN IN DOTTED LINE.
 I.F. TRANSFORMER WINDING STARTS WITH #1 TERMINAL, AS FIRST TERMINAL, AS VIEWED FROM BOTTOM OF COIL.
 I.F. FREQUENCY 455 KC, TUNING RANGE 535 KC TO 1620 KC.

ALIGNMENT PROCEDURE

Operation	Connect Dscillator To	Dummy Antenna	Input Sig. Frequency	Set Dial At	Trimmers	Purpose
1	Converter Grid	.5 Mfd.	455 Kc.	600 Kc	L4, L5, L6, L7	For I.F. Alignment.
2	One Turn Loop Coupled Loosely to Wave Magnet	—	1600 Kc.	1600 Kc.	C1F	Set Oscillator to Dial Scale
3	Wave Magnet	—	1400 Kc.	1400 Kc.	C1D, C1B	Align Detector and Antenna Stage

DENOTES CHASSIS

117 V.A.C.
30 WATTS.

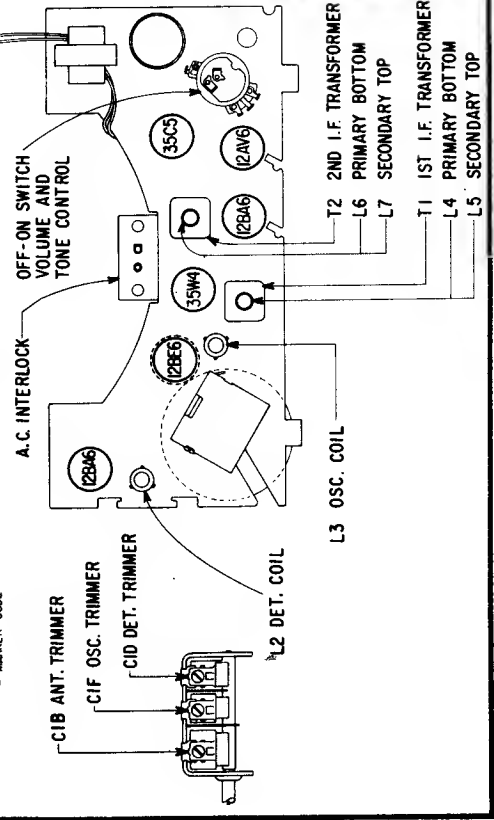
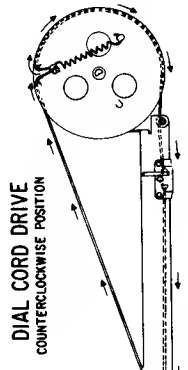

ZENITH RADIO

MODEL L624

CHASSIS 6L03

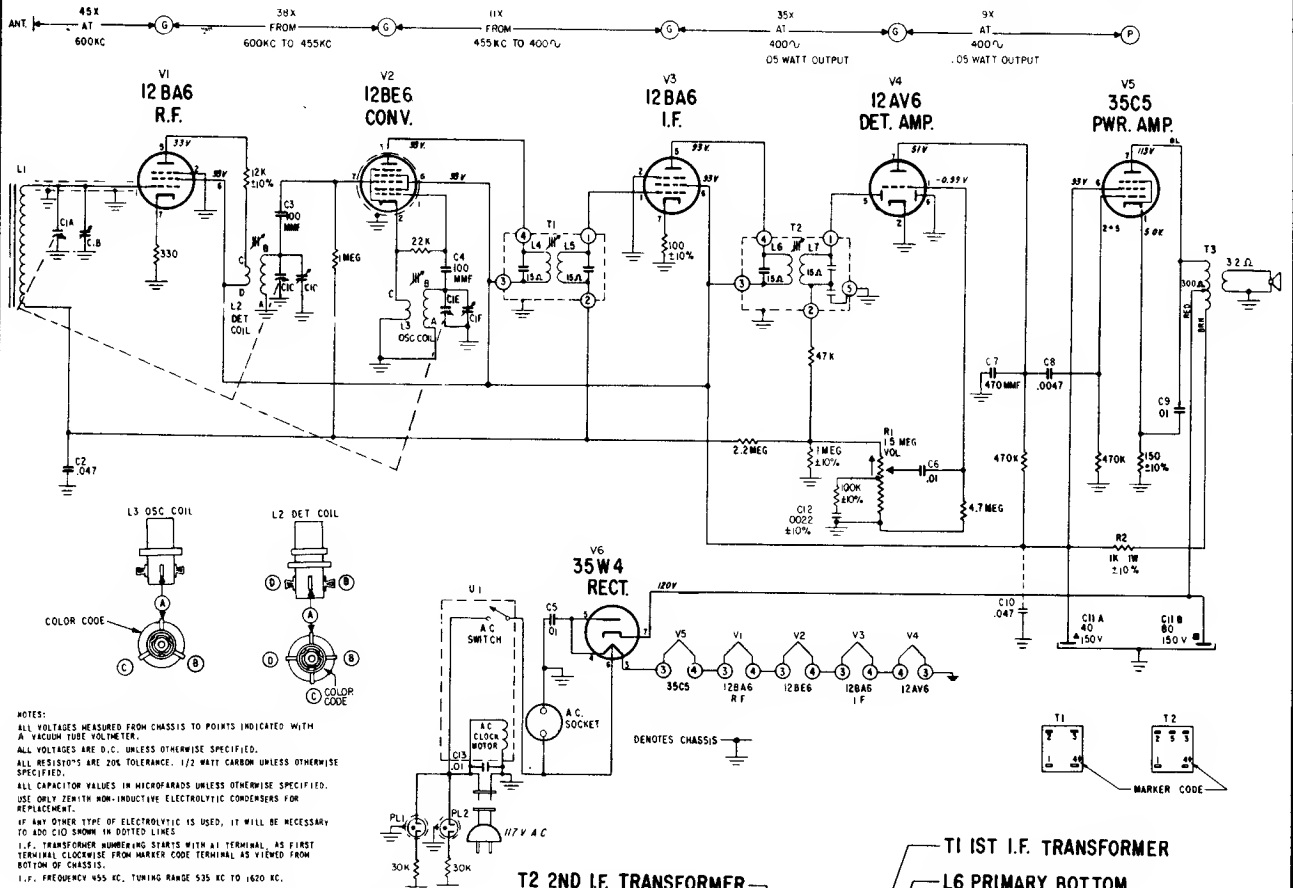

NOTES:
 ALL VOLTAGES MEASURED FROM CHASSIS TO POINTS INDICATED WITH A VACUUM TUBE VOLTMETER.
 ALL VOLTAGES ARE D.C. UNLESS OTHERWISE SPECIFIED.
 ALL RESISTORS ARE 20% TOLERANCE. 1/2 WATT CARBON UNLESS OTHERWISE SPECIFIED.
 ALL CAPACITOR VALUES IN MICROFARADS UNLESS OTHERWISE SPECIFIED.
 USE ONLY ZENITH NON-INDUCTIVE ELECTROLYTIC CONDENSERS FOR REPLACEMENT.
 IF ANY OTHER TYPE OF ELECTROLYTIC IS USED, IT WILL BE NECESSARY TO ADD C10 SHOWN IN DOTTED LINES.
 I.F. TRANSFORMER NUMBERING STARTS WITH A1 TERMINAL, AS FIRST TERMINAL CLOCKWISE FROM MARKER CODE TERMINAL AS VIEWED FROM BOTTOM OF CHASSIS.
 I.F. FREQUENCY 455 KC, TUNING RANGE 535 KC TO 1670 KC.

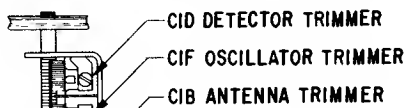

DIAL CORD DRIVE
 SHOWN IN FULL COUNTER
 CLOCKWISE POSITION

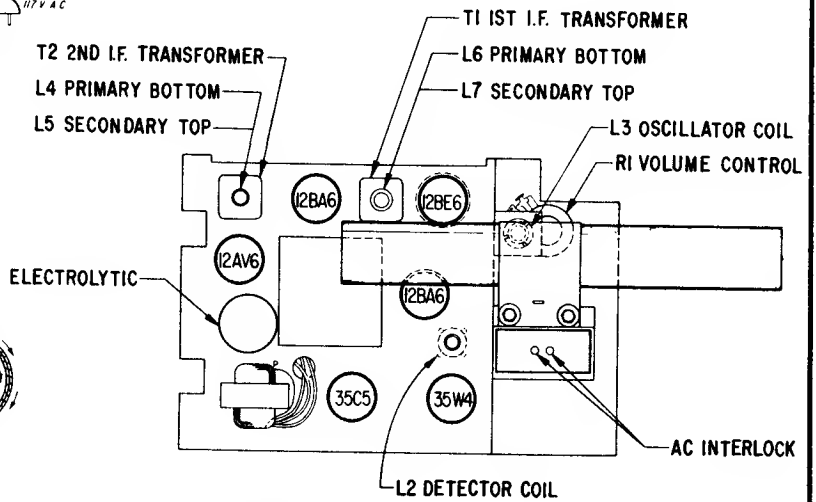

ALIGNMENT PROCEDURE

Operation	Connect Oscillator To	Dummy Antenna	Input Sig. Frequency	Set Dial At	Trimmers	Purpose
1	Converter Grid	.5 Mfd.	455 Kc.	600 Kc.	L4, L5, L6, L7	For I.F. Alignment.
2	One Turn Loop Coupled Loosely to Wave-magnet	—	1600 Kc.	1600 Kc.	C1F	Set Oscillator to Dial Scale.
3		—	1400 Kc.	1400 Kc.	C1D, C1B	Align Detector and Antenna Stage.

ZENITH RADIO MODEL L722C, G & W CHASSIS 6L06

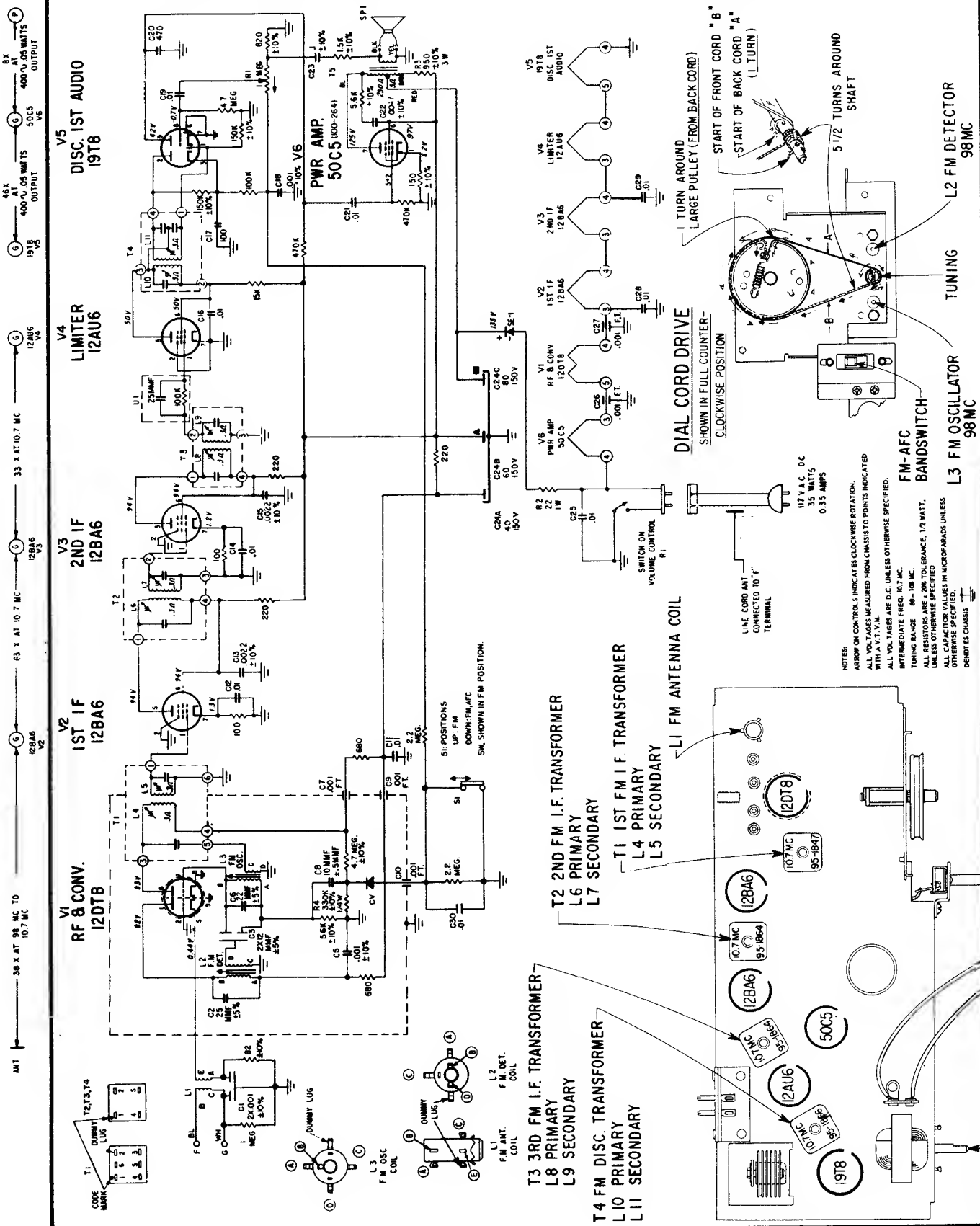

ZENITH 3L01 FOR MODELS SP401, MP401, ST1951, MT1951, MT1955, ST1959, SL2501 AND ML2601.

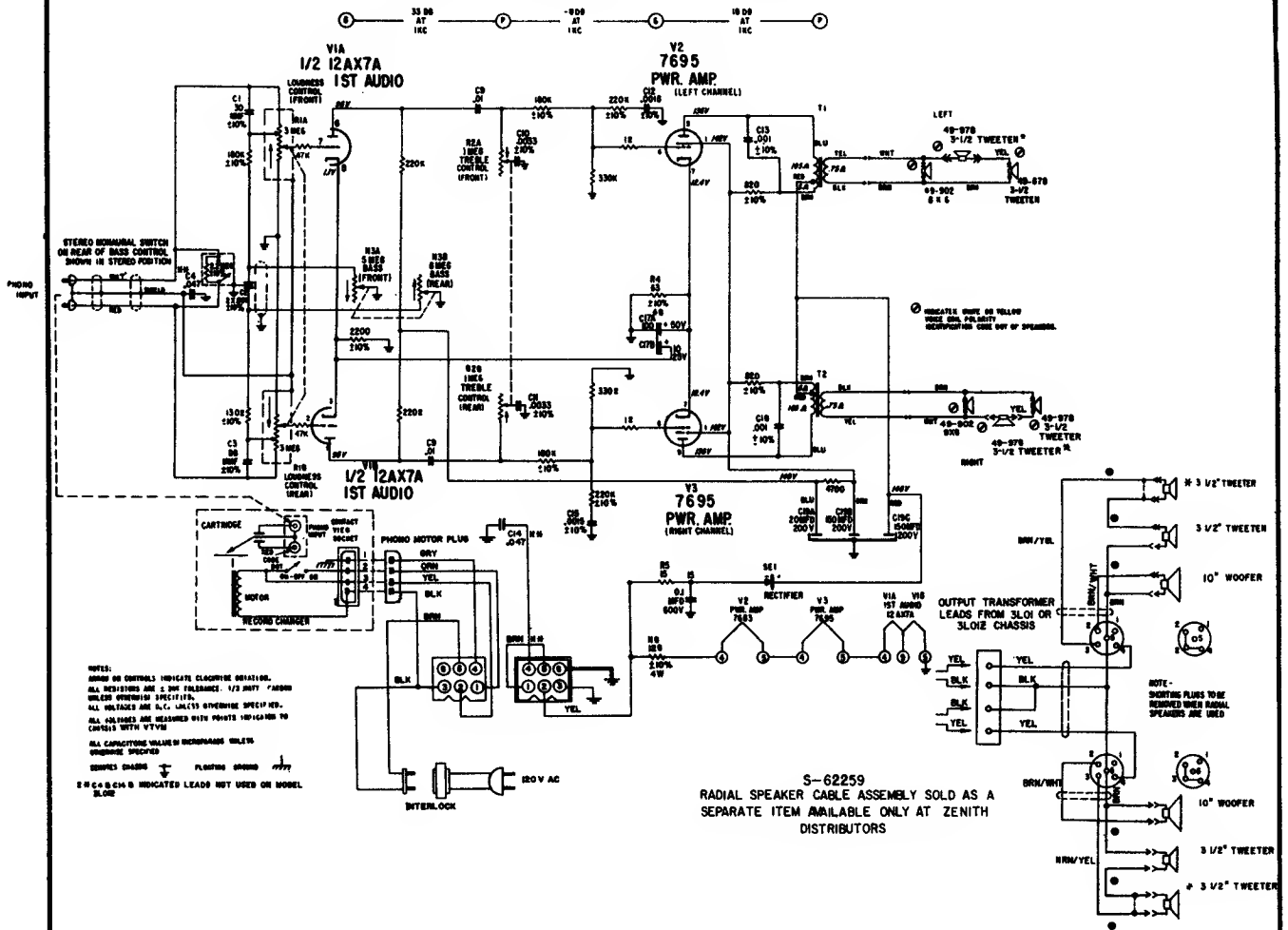

ZENITH Type 2L20 used in Models LPS45J, L

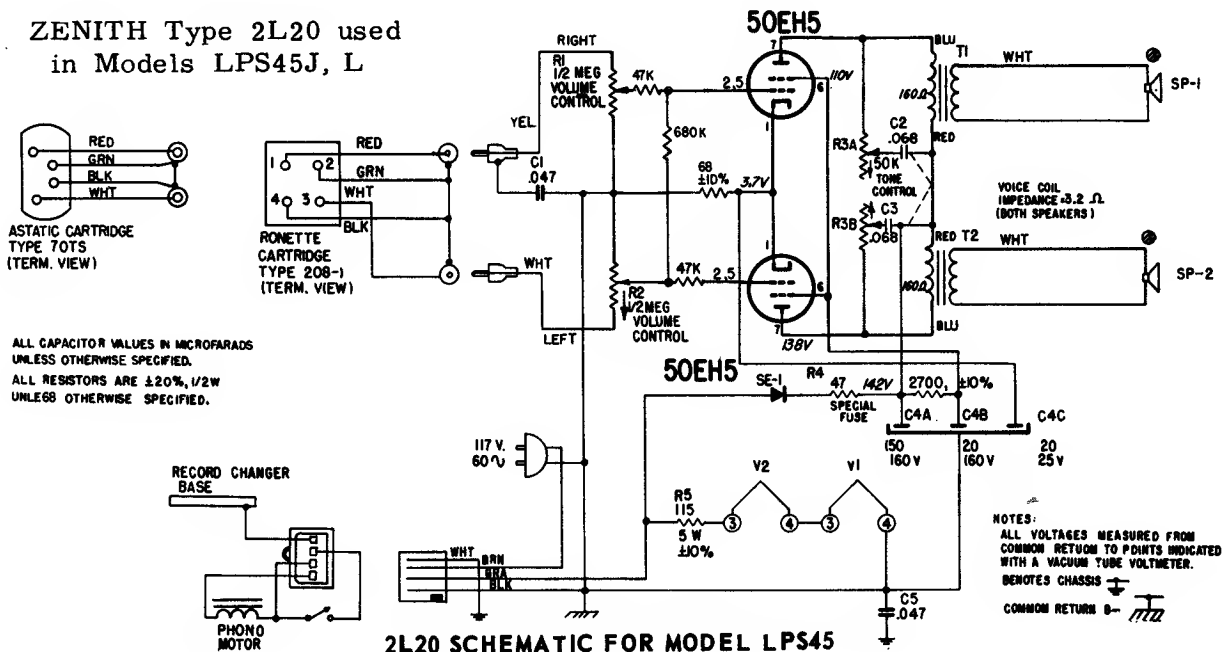

VOLUME R-24, MOST-OFTEN-NEEDED 1964 RADIO SERVICING INFORMATION

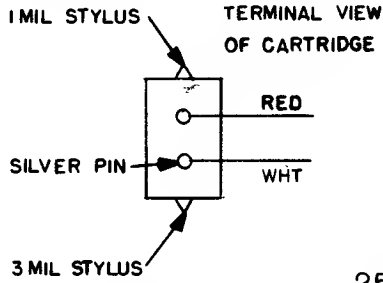

ZENITH 1L20 used in Models ZP2 types, and 1L21 used in Models LP8 types.

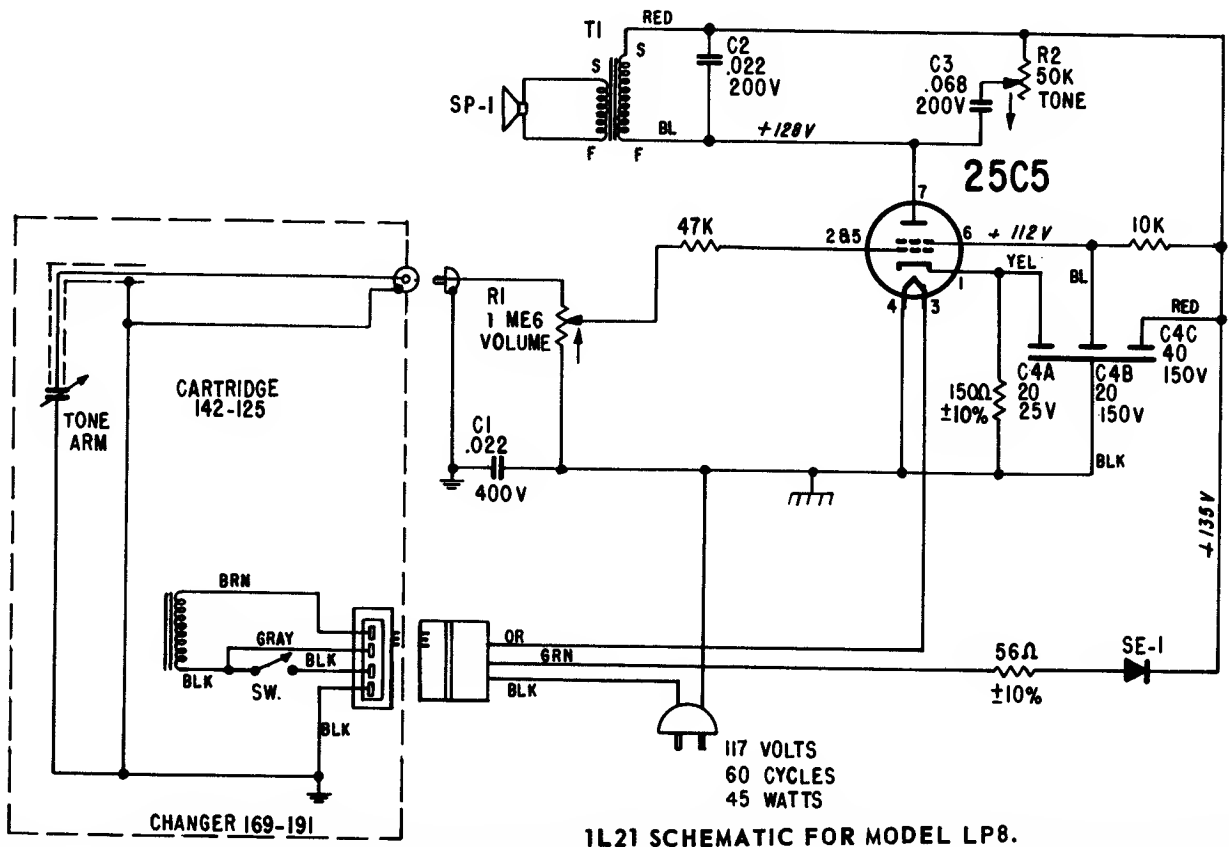
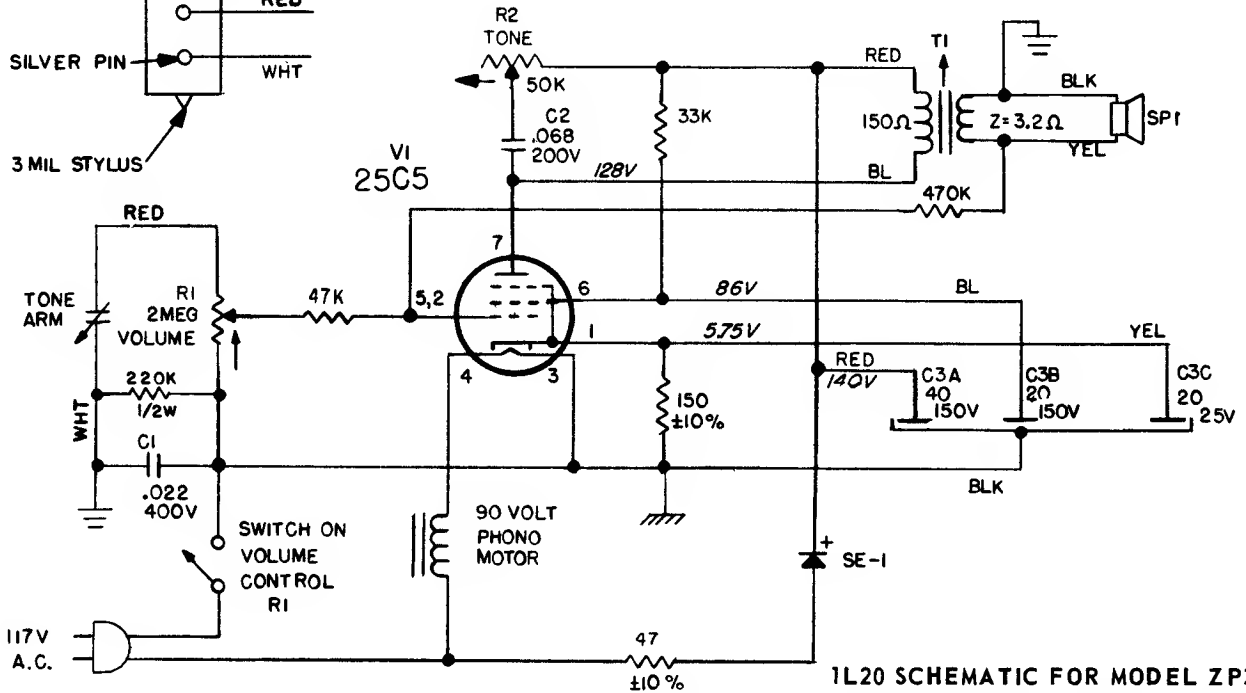

ZENITH 4L21 SCHEMATIC FOR MODELS ST1971, MT1971, ST1981, MT1981, ML2786 AND 7200. AUDIO OUTPUT SPEAKER TERMINAL STRIP

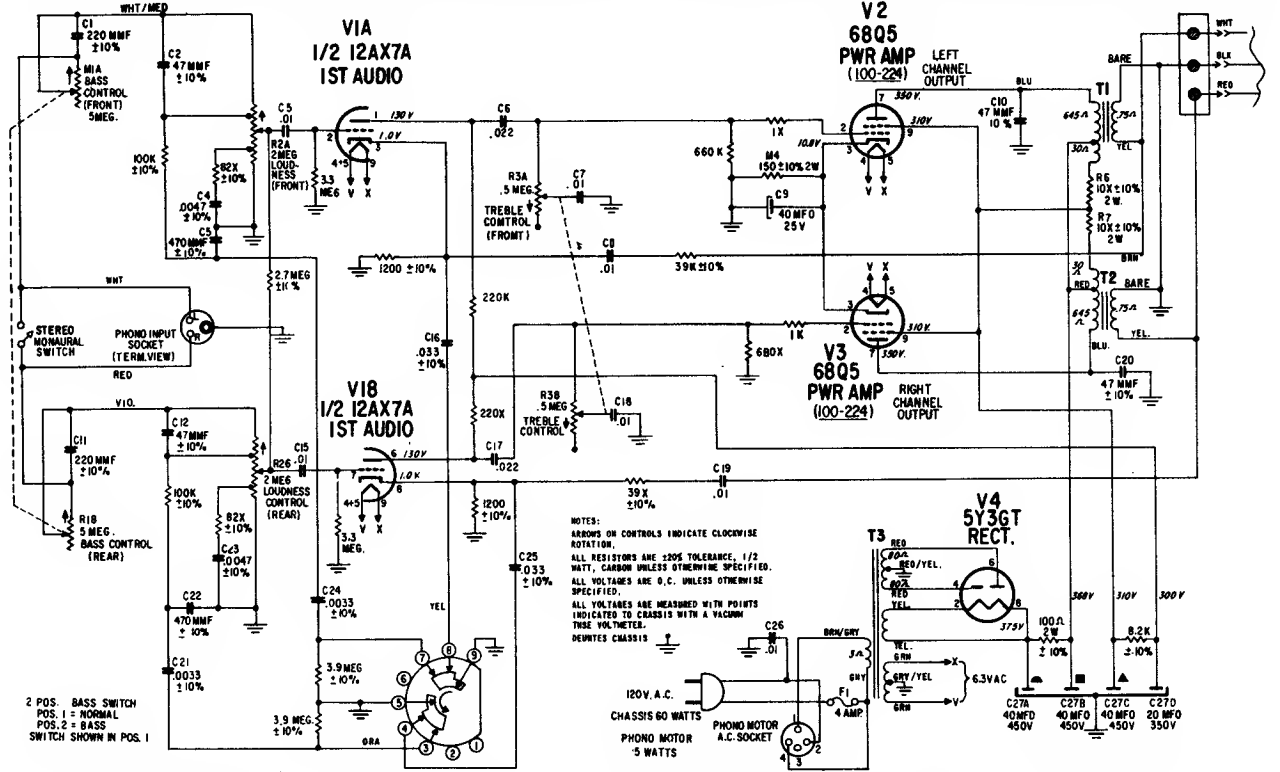

5L29 SCHEMATIC FOR MODELS SL2505, ML2605, ML2606, ML2607, ML2608, ML2610 AND ML2636.

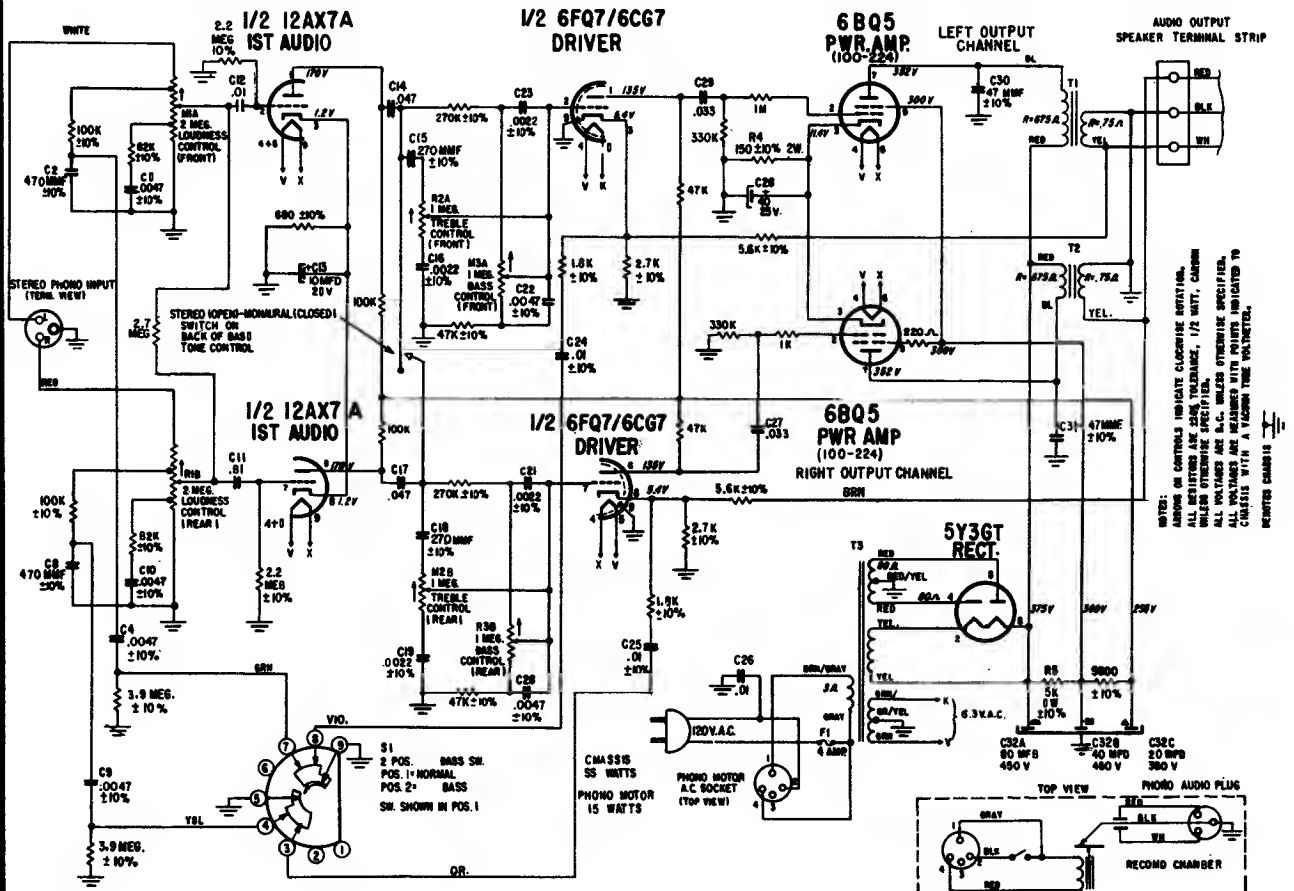

ZENITH

9L20 SCHEMATIC FOR MODELS ML2605, ML2606, ML2607, ML2608, ML2610, ML2636, ML2785, ML2786 AND 7200.

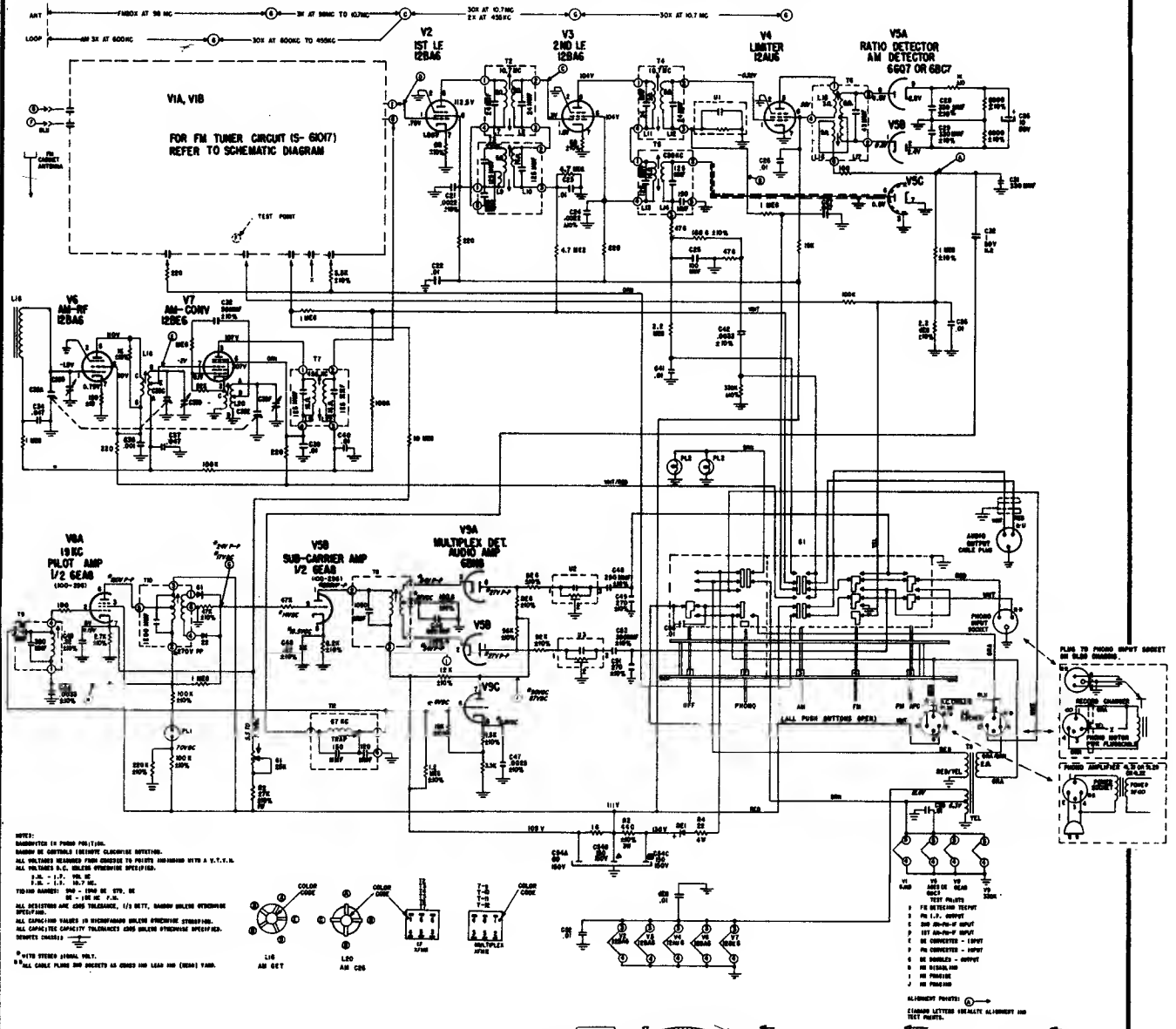

DIAL CORD DRIVE

SHOWN IN FULL COUNTERCLOCKWISE POSITION

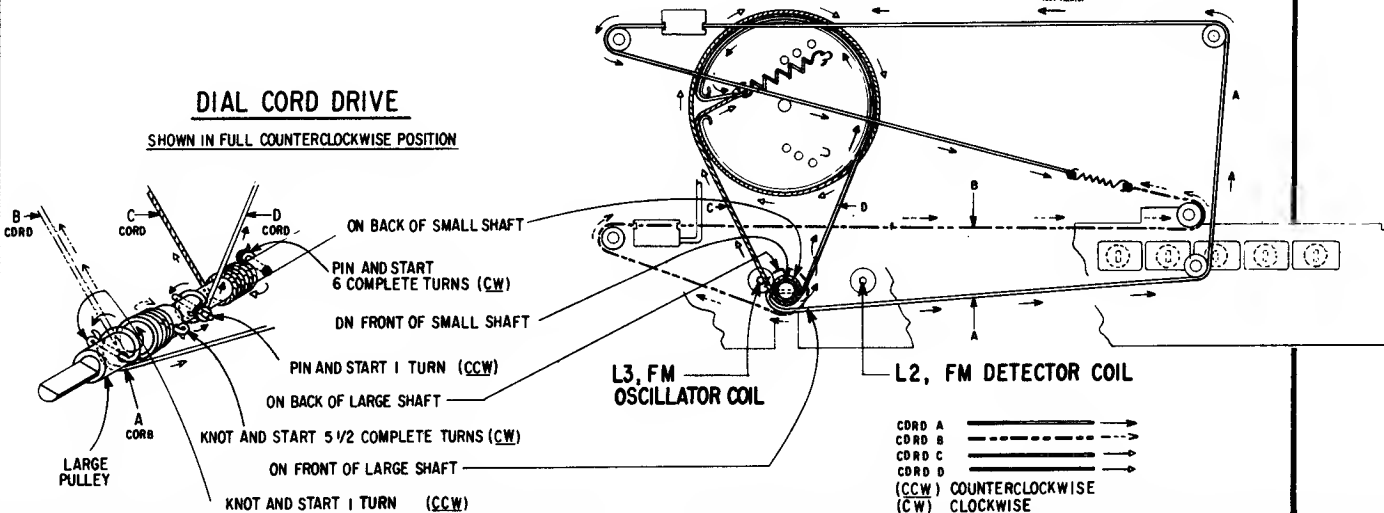

ZENITH

11L8T25 TUBE LAYOUT FOR MODELS
ML2668, ML2670, ML2675, ML2685 AND 7500.

TEST POINTS	
A	1st FM LIMITER GRID
B	2nd FM-AM I.F. GRID
C	2nd FM LIMITER GRID
D	AM CONV. GRID
E	1st FM-AM I.F. GRID
F	FM CONV. GRID
G	AM RF GRID
H	FM ANTENNA
J	RATIO DET. OUTPUT-67KC TRAP
K	MX, STEREO MONAURAL
L	19KC-DOUBLER
M	DET. COIL PEAK-PHASING
N	MX PHASING

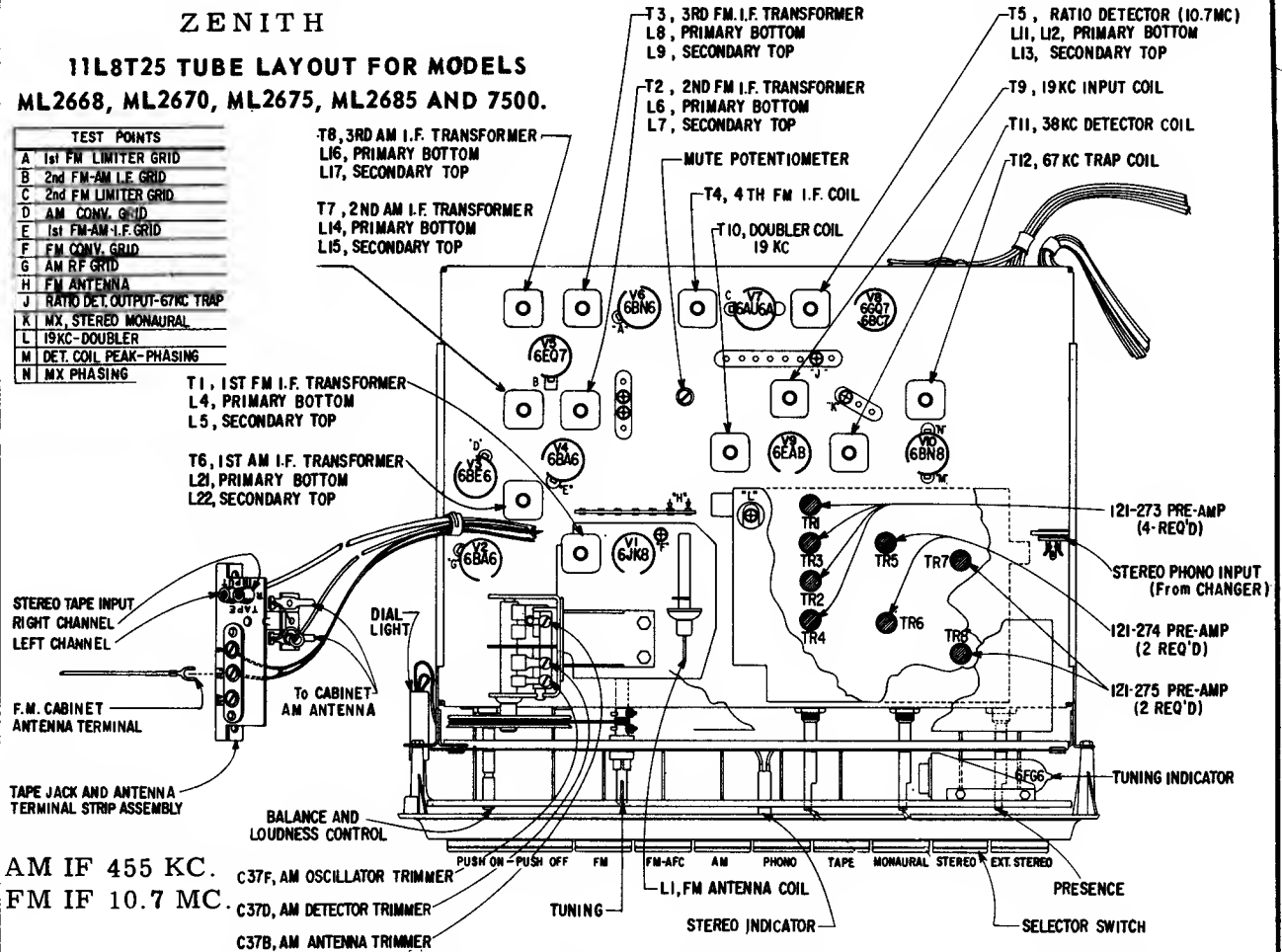

AM IF 455 KC.
FM IF 10.7 MC.

- C37F, AM OSCILLATOR TRIMMER
- C37D, AM DETECTOR TRIMMER
- C37B, AM ANTENNA TRIMMER

S-61017 AND S-61363 SCHEMATIC FOR FM TUNER USED ON CHASSIS 9L20 AND 11L8T25.

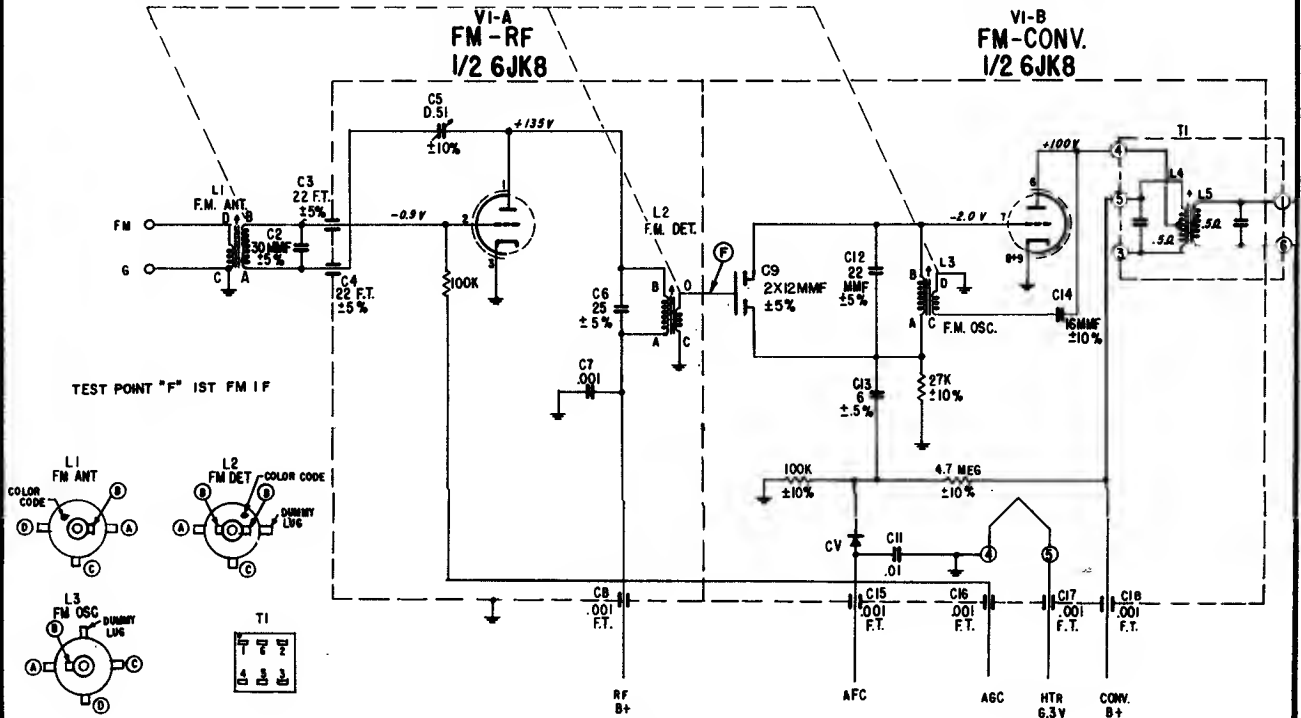

ZENITH 11L8T25 SCHEMATIC FOR MODELS ML2668, ML2670, ML2675, ML2685 AND 7500.

(For chassis layout and FM tuner schematic see page 189)

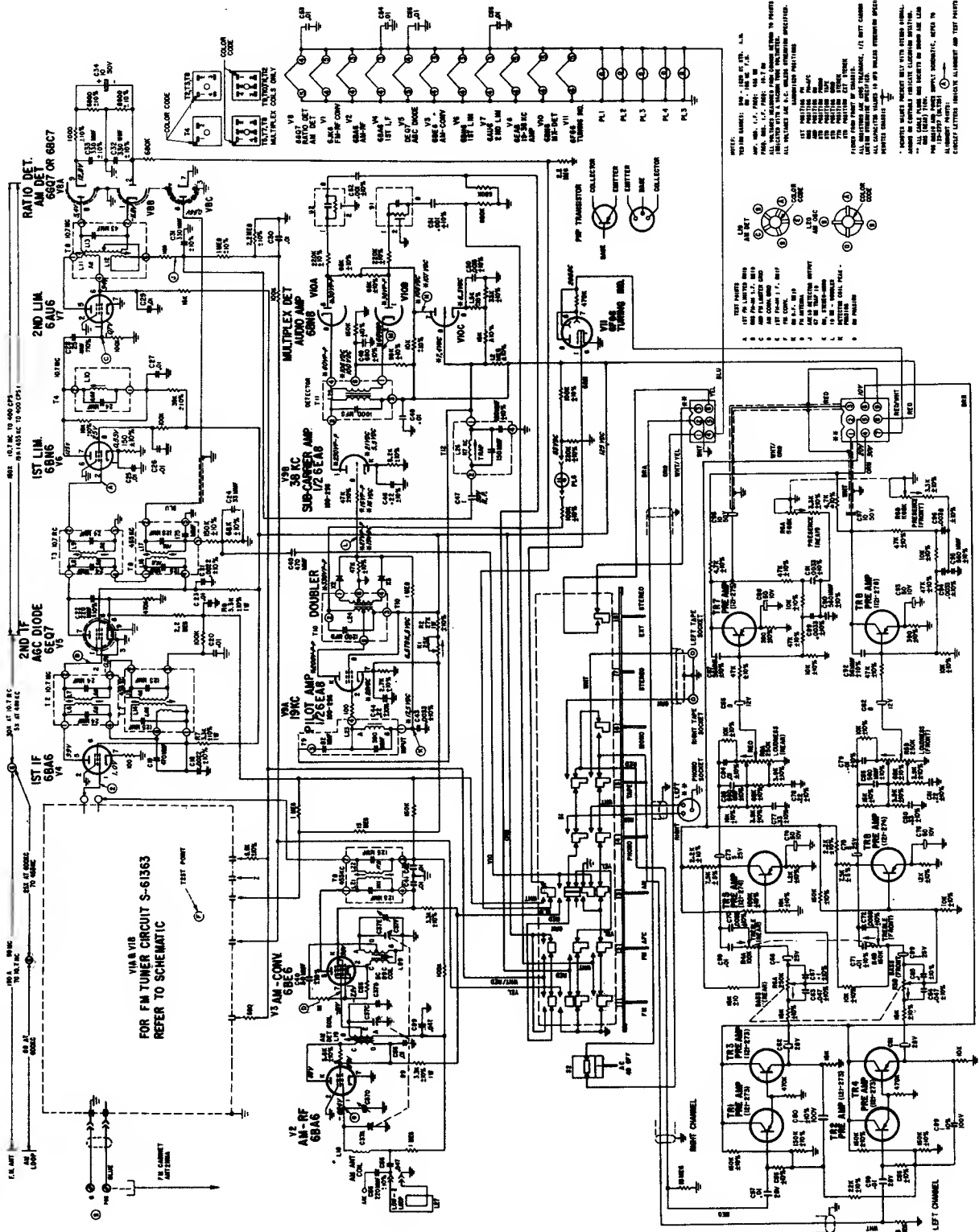

TEST POINTS:
 1. 1ST AF (V7) GRID
 2. 1ST AF (V7) CATHODE
 3. 2ND AF (V8) GRID
 4. 2ND AF (V8) CATHODE
 5. 3RD AF (V9) GRID
 6. 3RD AF (V9) CATHODE
 7. 4TH AF (V10) GRID
 8. 4TH AF (V10) CATHODE
 9. 5TH AF (V11) GRID
 10. 5TH AF (V11) CATHODE
 11. 6TH AF (V12) GRID
 12. 6TH AF (V12) CATHODE
 13. 7TH AF (V13) GRID
 14. 7TH AF (V13) CATHODE
 15. 8TH AF (V14) GRID
 16. 8TH AF (V14) CATHODE
 17. 9TH AF (V15) GRID
 18. 9TH AF (V15) CATHODE
 19. 10TH AF (V16) GRID
 20. 10TH AF (V16) CATHODE
 21. 11TH AF (V17) GRID
 22. 11TH AF (V17) CATHODE
 23. 12TH AF (V18) GRID
 24. 12TH AF (V18) CATHODE
 25. 13TH AF (V19) GRID
 26. 13TH AF (V19) CATHODE
 27. 14TH AF (V20) GRID
 28. 14TH AF (V20) CATHODE
 29. 15TH AF (V21) GRID
 30. 15TH AF (V21) CATHODE
 31. 16TH AF (V22) GRID
 32. 16TH AF (V22) CATHODE
 33. 17TH AF (V23) GRID
 34. 17TH AF (V23) CATHODE
 35. 18TH AF (V24) GRID
 36. 18TH AF (V24) CATHODE
 37. 19TH AF (V25) GRID
 38. 19TH AF (V25) CATHODE
 39. 20TH AF (V26) GRID
 40. 20TH AF (V26) CATHODE
 41. 21ST AF (V27) GRID
 42. 21ST AF (V27) CATHODE
 43. 22ND AF (V28) GRID
 44. 22ND AF (V28) CATHODE
 45. 23RD AF (V29) GRID
 46. 23RD AF (V29) CATHODE
 47. 24TH AF (V30) GRID
 48. 24TH AF (V30) CATHODE
 49. 25TH AF (V31) GRID
 50. 25TH AF (V31) CATHODE
 51. 26TH AF (V32) GRID
 52. 26TH AF (V32) CATHODE
 53. 27TH AF (V33) GRID
 54. 27TH AF (V33) CATHODE
 55. 28TH AF (V34) GRID
 56. 28TH AF (V34) CATHODE
 57. 29TH AF (V35) GRID
 58. 29TH AF (V35) CATHODE
 59. 30TH AF (V36) GRID
 60. 30TH AF (V36) CATHODE
 61. 31ST AF (V37) GRID
 62. 31ST AF (V37) CATHODE
 63. 32ND AF (V38) GRID
 64. 32ND AF (V38) CATHODE
 65. 33RD AF (V39) GRID
 66. 33RD AF (V39) CATHODE
 67. 34TH AF (V40) GRID
 68. 34TH AF (V40) CATHODE
 69. 35TH AF (V41) GRID
 70. 35TH AF (V41) CATHODE
 71. 36TH AF (V42) GRID
 72. 36TH AF (V42) CATHODE
 73. 37TH AF (V43) GRID
 74. 37TH AF (V43) CATHODE
 75. 38TH AF (V44) GRID
 76. 38TH AF (V44) CATHODE
 77. 39TH AF (V45) GRID
 78. 39TH AF (V45) CATHODE
 79. 40TH AF (V46) GRID
 80. 40TH AF (V46) CATHODE
 81. 41ST AF (V47) GRID
 82. 41ST AF (V47) CATHODE
 83. 42ND AF (V48) GRID
 84. 42ND AF (V48) CATHODE
 85. 43RD AF (V49) GRID
 86. 43RD AF (V49) CATHODE
 87. 44TH AF (V50) GRID
 88. 44TH AF (V50) CATHODE
 89. 45TH AF (V51) GRID
 90. 45TH AF (V51) CATHODE
 91. 46TH AF (V52) GRID
 92. 46TH AF (V52) CATHODE
 93. 47TH AF (V53) GRID
 94. 47TH AF (V53) CATHODE
 95. 48TH AF (V54) GRID
 96. 48TH AF (V54) CATHODE
 97. 49TH AF (V55) GRID
 98. 49TH AF (V55) CATHODE
 99. 50TH AF (V56) GRID
 100. 50TH AF (V56) CATHODE

INDEX

Under each manufacturer's name, at left there are listed that make chassis and models in numerical order. The corresponding page number at right of each listing refers to the first page of the section dealing with such material.

<u>Admiral Corp.</u>	<u>Arvin, Cont.</u>	<u>Delco</u>	<u>Emerson, Cont.</u>	<u>G. E. Continued</u>	<u>Montgomery Ward</u>
1F1B 3	43R43 15	300 21	P-1913 34	P895A-M 46	GEN-769A 61
4S3A 3	53R05 11	331 21	P-1914 36	P910A-M 46	GEN-951A 61
4X3,A 4	53R07 11	332 21	P-1915 39	P911 46	JWR-953A 60
5D6A 5	53R17 11	333 21	P-1926 37	P911A-M 46	JWR-956A 60
5D6B,C 5	53R19 11	AC-3351 22	P-1919 42	P912A-M 46	JWR-1033B 60
6X3,A 6	53R27 11	AC-3352 24	P-1920 42	P913A-M 46	JWR-1035B 60
7L2 7	53R28 11	AC-3353 22	P-1921 42	P915A,B 49	GEN-1730A 61
8G2 10	63R38 13	AC-3354 24	P-1923 43	P916A,B 49	GEN-1731A 61
8P1 8	63R58 12	AC-3377 24	P-1936 38	P917A,B 49	
9P1 8	83P15 14	980462 24	P-1937 38	P925A 50	
Y2347 7	83P43 14	980463 18	120486 28	P955A 51	<u>Motorola</u>
Y2351 10	83P53 14	980464 24	120567B 42	RP1530 56	BC2 82
Y3303 4	83P55 14	980626 21	120637 38	RP1590A,C 53	CX2 81
Y3308 4	1.67201 14	980635 21	120638 39	RC1641 54	BC3 82
Y3309 4	1.74301 15	980655 26	120639 35	RC1642 54	3AT 62
Y3321 4	1.74401 11	982136 24	120640 34	RC1651 54	3MT 62
Y3323 5	1.74501 11	982137 18	120646 40	RC1652 54	3TME 64
Y3337 4	1.75001 13	982149 22	120647 35	RC1660 55	3TMF 64
Y3346 5	1.75101 12	982212 21	120649 36	RC1661 55	3TMR 66
Y3353 5	1.75401 11	983873 24	120666 28	RC1662 55	3TMY 64
Y3354 5	1.76001 11	983874 22	120668 42	RC1663 55	A24 84
Y3359 5	1.77001 14	983875 24	120670 43	RC1664 55	C34 85
Y3363 5	1.78001 15	985396 18	120685 29	RC1670 55	C35 85
Y3364 5		985431 22	120686 41	RC1671 55	C36 85
Y3368 5		985432 24	120693 37	RC1672 55	SP41 100
Y3376 5	<u>Buick</u>	985443 22	and 42	RC1673 55	SP42 100
Y3377 5	980462 24	985447 22	120700 29	RC1674 55	X42 86
Y3379 5	980463 18	985449 24	120701 41	RP2080 54	X42-1 86
Y3381 5	980464 24	985453 22	120713 28	RP2081 54	SP43 100
Y3383 5	980626 21	985455 24		RP2085 54	SP44 102
Y3421 6	980635 21	985471 24	<u>Ford</u>	RP2090 54	S P44-1 102
Y3426 6	980655 26	985686 21	C3AA-18806 64	RP2091 54	X47 87
Y3431 6		2234003 24	C3GA-18806 64	RP2095 54	X48 88
Y3436 6	<u>Cadillac</u>	7282315 18	C3YA-18806 64	RP2110 56	X49 89
Y3443 4	7282315 18	7283295 21		RP2111 56	X50 89
Y4659 3	7283295 21		<u>Gamble-Skogmo</u>	RP2113 56	SP51 93
Y4677 3		<u>Delmonico</u>	RA60-9921A 44	RP2130 56	X51 90
Y4851 8	<u>Channel Master</u>	8B-2 17	RA60-9922A 44	RP2131A 56	SP52 94
Y4852 8	6535 16		RA60-9924A 44	RP2138A 56	HK53-1 95
Y4871 8		<u>Dodge</u>		RC4670 55	HK53-2 95
Y4872 8	<u>Chevrolet</u>	331 21	<u>General</u>	RC4671 55	HK54-2 96
Y4885 8	985396 18	332 21	<u>Electric</u>	RC4672 55	X54 91
Y4918 3	985431 22		T215A 52	RC4675 55	X56 92
Y4941A 8	985432 24	<u>Emerson Radio</u>	T216A 52	RC4679 55	BKA63 62
	985443 22	911 28	H220A 45	P9151A,B 49	CA63 68
<u>American</u>	985447 22	990 28	H221A 45	P9161A,B 49	CRA63 68
<u>Motors</u>	985449 24	991 28	T265A 52	P9171A,B 49	CRM63 69
8991142 66	985453 22	G-1700 29	T266A 52		CTA63 62
	985455 24	G-1707 30	C540A 52	<u>Hitachi</u>	CTM63 62
<u>Arvin</u>	985471 24	G-1708 32	C541A 52	TH-650 57	CYA63 68
13R35 11	985686 21	G-1709 29	P807G,H 48		CYM63 69
13R37 11		G-1710 41	P807S,T 48	<u>Magnavox</u>	OEA63 68
33R28 15	<u>Chrysler</u>	G-1711 41	P808G,H 48	59 Series 59	PCA63 62
33R29 15	333 21	G-1713 29	P808S,T 48	93 Series 58	VWA63 71

(INDEX continued on page 192)

VOLUME R-24, MOST-OFTEN-NEEDED 1964 RADIO SERVICING INFORMATION

INDEX Continued

Motorola, Cont.	Philco	RCA Continued	RCA Continued	Westinghouse+	Westinghouse+
VWM63 70	T-67 105	4RA34 132	RC-1213A 132	H-62MFS3A 167	V-2522-1 171
X70 86	T-68 106	4RA41 132	RC-1213B 132	H-69ACS1A 167	V-2522-2 171
SK100-4 99	T-81 108	4RA42 132	RC-1213E 132	H-75AC1A 167	V-2522-3 171
SK103 100	T-84 107	4RA45 132	RC-1213F 132	H-75AC2A 167	V-2523-1 169
SK104 100	T-90 110	4RD4 132	RC-1213H 132	H-79ACS1B 171	V-2527-1 170
SK105 100	T-703 111	4RD5 132	RC-1214A 143	H-79ACS2B 171	V-2527-2 170
SK106 98	M-709 112	4RD4.0 132	RC-1215A 140	H-85MP1 168	
SK107 98	M-712 113	4RD4.1 132	RC-1215B 140	H-85MP2 168	
SK108 100	M-714 113	4RD4.4 132		H-85MP3 168	
SK109 98	M-715 113	4RD5.1 132	Sears, Roebuck	H-86ACS1A 170	Zenith Radio
SK110 98	M-716 113	4RD5.2 132	4001 144	H-86ACS2A 170	1L20 186
SK-111 97	M-719 114	4RD5.5 132	4002 144	H-86ACS3 170	1L21 186
SK-112 97	M-798 114	4RG1 137	4003 144	H-88ACS1 171	2L20 185
SK-115 97	M-869 112	4RG3 137	4030 145	H-89ACS1 169	ZP2 186
SK-116 97	M-871 113	4RG5 143	4032 146	H-90ACS1 171	3L01 185
SK124 99	M-872 113	4RG6 143	4033 146	H-90ACS2 171	4L21 187
SK125 99	M-874 113	4RG11 137	4034 146	H-90ACS3 171	5L07 175
216 72	M-876 113	4RG12 137	4043 147	H-96AC1 167	5L29 187
217 72	T-902 (128) 115	4RG16 137	4044 147	H-96AC2 167	6K05 181
290T 76	T-907 116	4RG31 137	4079 148	H-839N5 162	6KTH.0Z1 176
323T 78	T-911 120	4RG34 137	4080 148	H-846P8++ 160	6KTH.0Z8 177
337 72	M-936 114	4RG51 143	4081 148	H-848N5 161	6KTH.1Z1 179
339 72	M-937 114	4RG52 143	4082 148	H-849N5 161	6KTH.2Z1 178
344 72	M-938 114	4RG56 143	132.75901 144	H-850N6 164	6KTH.5Z1 178
345 72	M-939 114	4RG61 143	528.53500 146	H-851N6 164	6KTH.7Z1 174
413T 80	M-14.16 123	4RG62 143	528.54400 145	H-852N6 164	6L03 182
SP511 94	M-14.21 122	4RG66 143	528.54670 147	H-855LN6 164	6L06 183
HS-996 96	M-14.28 119	4VC64 131	528.54880 148	H-856LN6 164	7KTH.5Z1 180
HS-998 85	M-14.30 119	4VC69 131		H-871N6 164	7L04 184
HS-1011 86	M-15.29 122	4VC82 131	Sony	H-872N6 164	ZP8 186
HS-1048 97	M-15.37 123	4VE04.5 131	TR-727 149	H-873N6 164	9L20 188
HS-104.9 98	L-16.51 124	4VE04.6 131	TR-730 150	H-875LN6 164	11L8T25 189
HS-1050 97	L-16.52 124	4VF095 140	TR-7170 151	H-876LN6 164	LPS4.5J,L 185
HS-1051 98	L-16.53 124	4VF096 140		H-877LN6 164	50L 177
HS-1055 100	L-16.56 129	4VF105 140	Studebaker	H-880T5 166	130 174
HS-1058 102	L-16.67 129	4VF106 140	AC-3351 22	H-881T5 166	265 178
HS-1059 100	L-16.79 129	4VF114 140	AC-3352 24	H-881T5 166	MP401 185
HS-1061 100		4VF124 140	AC-3353 22	H-M1760 172	SP401 185
HS-1102 100	Plymouth	4VF145 140	AC-3354 24	H-M1761 172	490 180
HS-1117 95	300 21	4VF146 140	AC-3377 24	H-M1763 172	L519C,+ 175
HS-1123 95	Pontiac	4VF156 140		H-M1790 172	K615B,C,W 181
HS-1125 102	983873 24	4VF156 140	Sylvania	H-M1791 172	L624 182
HS-1134 93	983874 22	4VF206 140	SC26 153	H-M1793 172	645 178
HS-1135 94	983875 24	4VF224 140	45P20 152	H-M1810/A 172	670 178
HS-1192 101		4VF282 140	45P32 152	H-M1810B 172	L722C,G,W 183
HS-1201 99	RCA Victor	4VF289 140	45P34 156	H-M1811/A 172	L723C,G,W 184
HS-4124 82	3VC64 131	4VF304 138	45P35 156	H-M1811B 172	MT1951 185
HS-4136 84	3VC82 131	4VF325 138	405-1 152	H-M1813/A 172	MT1955 185
HS-6108 87	3VF305 134	4VF326 138	406-1 152	H-M1813B 172	ST1959 185
HS-6110 81	3VF306 134	4VF348 138	407-1 156	H-M1815/A 172	SL2501 185
HS-6111 88	3VF34.0 134	4VF34.9 138	702-2 153	H-M1815B 172	SL2505 187
HS-6112 89	3VF34.6 134	4VF405 138		H-M1910 172	ML2601 185
HS-6114 90	3VF34.9 134	4VF446 138	Toshiba	H-M1911 172	ML2605 187
HS-6117 86	3VF405 134	4VF464 138	7TP-30 157	H-M1913 172	ML2606 187
HS-6118 86	3VF446 134	4VF480 138	7TP-403Y 157	H-M1914 172	ML2607 187
HS-6123 91	3VF516 134	4VF488 138		V-24.26-3,M 160	ML2608 187
HS-6124 92	3VF534 134	4VF534 138	Webcor	V-24.27-1 161	ML2610 187
	3VF604 134	RS-177H 134	1153 158	V-24.27-2 162	ML2636 187
	3VF619 134	RS-177J 138	1353 159	V-24.28-3 164	ML2668 189
Oldsmobile	3VF646 134	RS-199B 134	1354 158	V-24.28-4 164	ML2670 189
982136 24	4RA1 132	RS-199C 138	1356 159	V-24.50-1 166	ML2675 189
982137 18	4RA3 132	RS-202A 131	1450 159	V-2507-7 167	ML2685 189
98214.9 22	4RA4 132	RS-202B 131		V-2508-2 167	ML2785 188
982212 21	4RA10 132	RS-203A 140	Westinghouse	V-2508-5 167	ML2786 188
	4RA14 132	RC-1205C 134	ED-1 163	V-2508-11 168	7200 188
	4RA15 132	RC-1208D 137	ED-2 163	V-2508-13 168	7500 189
	4RA30 132	RC-1208H 137	H-62MFS1A 167	V-2508-14 167	S-61017 189
	4RA31 132	RC-1211A 138	H-62MFS2A 167	V-2515-4 172	S-61363 189
				V-2515-8 172	S-62259 185